

Mini Excavator Hydraulic Hammer

User Manual



Read Carefully Before Use
Keep for Future Reference

Contact Us

Thank you for choosing our products! If you have any questions or comments, contact us at help@cs-supportpro.com and we'll resolve your issue ASAP!

For a .pdf copy of the latest version of these instructions, use the appropriate app on your smartphone to scan the QR code to the right.



Disclaimer

Read this disclaimer carefully **BEFORE** use.

1. **As-is**

This product(s) is sold 'as is' and without any express or implied warranties, including but not limited to the implied warranties of merchantability and fitness for a particular purpose.

2. **Product Modifications**

Any modifications or alterations to AHM products void any warranties and may result in damage or injury. AHM shall not be liable for any damages resulting from such modifications or alterations.

3. **Compliance with Laws**

Customers shall be liable for ensuring that the use of AHM products complies with all applicable laws and regulations in their respective jurisdictions. AHM assumes no responsibility for any violations of laws or regulations resulting from the use of its products.

4. **Correct Use**

Always use the product(s) only as directed in the accompanying manual. Failure to follow instructions may result in injury or damage.

Always ensure the operation, installment, maintenance, and repair of the product(s) is carried out by a competent person.

Always make maintenance regularly throughout the product lifecycle, you have the liability to keep the product operating as intended.

Always wear appropriate protective gear.

5. **Third-Party Products**

AHM shall not be liable for any damages or losses resulting from the use of third-party products in conjunction with our products. Customers should refer to the third-party's guidelines or/and warranties (if any) for any third-party products used.

6. **Limitation of Liability**

AHM shall not be liable for any direct, indirect, punitive, incidental, special, or consequential damages to property or life, whatsoever arising out of or connected with the use or misuse of our product(s). In no event shall AHM's liability exceed the value of the product(s) sold.

This disclaimer states the entire obligation of AHM with respect to the products. If any part of this disclaimer is determined to be void, invalid, unenforceable, or illegal, including, but not limited to the warranty disclaimers, liability disclaimers, and liability limitations set forth above, then the invalid or unenforceable provision will be deemed superseded by a valid, enforceable provision that most closely matches the intent of the original provision and the remainder of the agreement shall remain in full force and effect.

Safety Information

Symbol Guide

The following symbols and safety signal words are used in this manual. **DO** obey the accompanying messages to avoid possible injury or death.



Indicates an imminently hazardous situation which, if not avoided, **WILL** result in death or serious injury.



Indicates a potentially hazardous situation which, if not avoided, **COULD** result in death or serious injury.



Indicates a potentially hazardous situation which, if not avoided, **MAY** result in minor or moderate injury. It may also be used to alert against unsafe practices.



Indicates practices or situations which may result in the malfunction of, or damage to equipment.

General Safety

Danger

- **ALWAYS** follow federal, state, and local laws, codes, and regulations concerning the use of construction machinery.
- Follow all other applicable instructions and precautions as stated in your excavator's manual.
- Read this manual before actually attaching this hydraulic hammer to your compatible excavator. Familiarize yourself with the instructions that provide crucial information on the installation, operation, and maintenance.
- **ONLY** use with compatible excavator models. Though this hydraulic hammer has a wide fitment, **DO** research compatibility before actually mounting this hydraulic hammer. For details, see **Specifications**.
- **ALWAYS** use personal protective equipment (PPE) suitable to your task. Always wear ANSI and OSHA-approved eye, breathing, and hand protection while using this product. Nonslip and steel-toe footwear is also highly recommended. Other equipment such as ear, head, and body protection may also be necessary depending on your work, work environment, and other equipment.
- **DO NOT** operate, inspect, or maintain the excavator when your faculties or judgment are impaired by alcohol, drugs, medicines, fatigue, or lack of sleep. **NEVER** allow any persons under such conditions to operate, inspect, or maintain this heavy machinery.
- Operating heavy equipment requires your full attention. Avoid distractions and remain focused on the task at hand.
- **IMMEDIATELY** cease to use and contact Customer Service if the hydraulic hammer shows any sign of anomalies or malfunctions, say noise, vibration, breakage, etc. **NEVER** attempt to resume use if the issues remain unsolved.

Operation Safety

Danger

- **FLYING DEBRIS CAN CAUSE SERIOUS OR FATAL INJURY.** Never operate the hammer with bystanders or any personnel unprotected from potential flying debris. Guard the perimeter with steel mesh and reinforce the excavator with equivalent material as well. **NEVER** operate the hammer with the excavator cabin unprotected.
- **ONLY** use nitrogen for the hammer piston. **ALWAYS** charge to the recommended pressure.
- **ONLY** operate the hammer from the excavator's cabin.
- **NEVER** demolish a structure overlooking the excavator with even the excavator well-protected.
- **DO NOT USE THE HAMMER AS A HOIST.** The hammer is not intended to lift an object. To do so may cause the excavator to turn over.
- Use two or more persons to attach the hammer to the excavator arm and arm cylinder.

Caution

- **AVOID BLANK HAMMERING.** As soon as the material is broken, release the control lever or pedal to prevent unnecessary blank hammering.

***Note:** Blank hammering is continued hammer operation after the material is broken. This will overheat the hydraulic system, cause undue wear, and result in eventual tool retaining pin failures.*

- Do not slant the hammer. Slanting the hammer can shorten the service life of the hammer.
- Do not use the hammer as a pry bar. Excessive prying can cause premature bushing wear and chisel rod breakage. When hammering materials that allow the tool to penetrate before breaking, move the hammer slightly fore and aft to create a cone-shaped hole. The vented hole allows trapped dust and heat to escape, increases the tool penetration rate into the material, and prevents the chisel tip from overheating.
- **DO NOT HAMMER CONTINUOUSLY IN THE SAME POSITION FOR MORE THAN 30 SECONDS.** If the chisel cannot break or penetrate the material after hammering in the same position for 30 seconds, change the impact point. Hammering in the same position for a long time will reduce the working efficiency, increase the hydraulic oil temperature, overheat the chisel tip, and shorten the hammer's lifespan.
- **ALWAYS WORK BY BREAKING TO A FREE FACE.** The material must have somewhere to break. Start at an edge.
- **DO NOT DROP THE HAMMER RAPIDLY TOWARD AN OBJECT.** Remember, the hydraulic hammer is heavier than an empty bucket and will move faster than expected.
- **DO NOT** use the hammer to move or nudge large objects, as they can cause excess wear around the chisel bushing.
- Avoid operating the hammer with its cylinder fully extended or depressed. Prolonged time of over-extension or depression incurs excess wear and tear, thus shortening the service life of the cylinder.

- **DO NOT** operate the hammer underwater. Do not allow the hammer, except its chisel, to go underwater. Otherwise, the hydraulic system **WILL** be damaged.
- **DO NOT** immerse the chisel in water when it is hot. The chisel may heat up as it smashes through hard rocks, concrete, or other similar hard materials. If submerged under water, the sudden cooling may embrittle or even break the chisel. Either way, the chisel is ruined.
- Maneuver the chisel clear of the excavator boom, especially when tucking the hammer into the boom for transportation.

Maintenance Safety

- Wear personal protective equipment (PPE) appropriate and adequate for the work at all times.
- **ONLY** use the recommended lubricant for the hammer. For the specific type, see **Maintenance**.
- Store the nitrogen canister following all applicable laws and codes concerning the safe storage of such substance. Keep the canister away from direct sunlight and flammables.
- Do not hardface or sharpen the chisel tip with a cutting torch. Excessive heat from torching or welding can cause embrittlement, breakage, and flying pieces. Re-sharpen by milling or grinding only, using sufficient coolant. Mind that re-sharpening is only recommended when the tip of the chisel has become dull. Breakage or wear of any kind to parts other than the tip entails the replacement of the whole chisel. See **Chisel Replacement** for details.

Specifications

Name		Mini Excavator Hydraulic Hammer	
Chisel	Diameter	1.37 in.	35 mm
	Pressure	1305.3–1740 (psi)	9–12 (MPa)
	Impact Frequency	500–1200 (bpm)	
Hammer Pin	Dimensions	160×25×25 (mm)	
Hose	Length	59.1 in.	1500 mm
	Port Size	M14×1.5 (to Hammer), M16×1.5 (to Excavator)	
Hydraulic Oil	Operating Pressure	1138.7–1567.6 (psi)	80–110 (kg/cm ²)
	Flow	2.6–7.9 (GPM)	10–30 (L/min.)
Compatible Excavator Specs.	Arm Pin I.D.	25 mm	
	Arm Pin Housing Distance	92 mm	
	Arm Pin Hole No.	2	
	Hydraulic Hose Port Size	M14×1.5, M16×1.5	
	Weight	<4409 lb.	<2 metric tons
Net Weight		165.3 lb.	75 kg
Nitrogen Charge Kit	Gauge	Inlet	3/8"
		Pressure	0–1400 (psi) 0–100 (kg/cm ²)
	Hose Port		3/8", 5/8"
	Canister Valve Outlet		5/8"

Package List

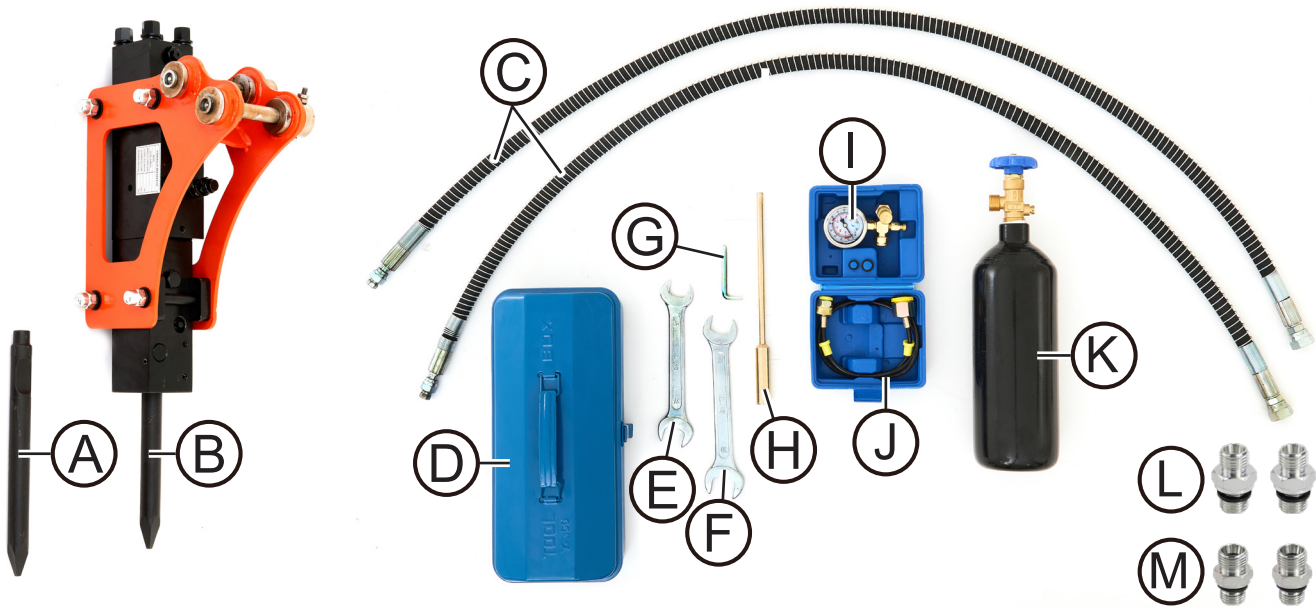

No.	Item	Qty.
A	Spare Chisel	1
B	Hammer Assembly	1
C	Hoses	2
D	Toolkit Box	1
E	24×27mm Wrench	1
F	27×30mm Wrench	1
G	Hex Wrench	1
H	Retaining Pin Plug Driver	1
I	Pressure Gauge	1
J	Nitrogen Charge Hose	1
K	Nitrogen Canister	1
L	M14×1.5 Male to M16×1.5 Male Thread Adapters	2
M	M14×1.5 Male to M14×1.5 Male Thread Adapters (These adapters can be used for other attachments as needed)	2

Product Diagram

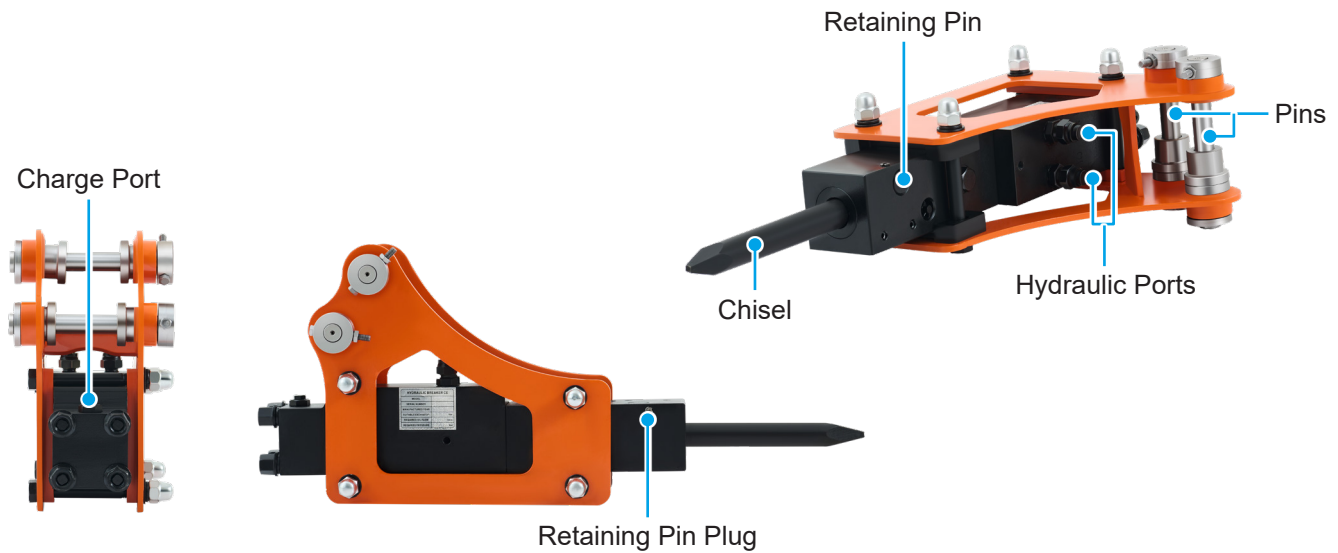

Installation

Warning

- **ONLY** mount the hammer assembly with the help of more than 2 persons or with the assistance of a working, easily controllable, and reliable hoist. Doing it alone risks serious personal injuries.
- If the excavator has been active before the mounting, wait till the hydraulic oil has dropped to ambient temperature.
- Keep your fingers clear of possible pinching points while mounting the hammer.

Caution

- Cover the hammer and excavator hydraulic ports once their plugs are removed, preventing foreign matter from entering the hydraulic system.
- Position the hammer on the wood blocks so that the chisel is at a lower level than the nitrogen chamber. This prevents foreign matter such as moisture or fine debris from entering the hammer.
- **ALWAYS** follow the protocols for using a hoist.

Attach the arm pin first, then the attachment bracket pin, and finally the hydraulic hoses. Doing it alternatively could cause serious personal injuries or machinery damage.

Removing the Old Attachment

Tools Needed:

Adjustable Wrench

Plastic Wrap

Hoist or an Extra Couple of Hands

1. Park the excavator as shown, with the boom horizontal, the arm vertical, and lowering the attachment to the ground.

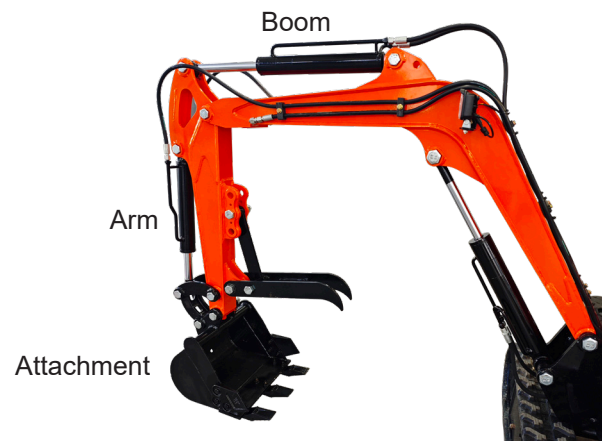

2. Shut off the engine.
3. Move all control levers to release the hydraulic system pressure.
4. Wait until the engine and hydraulic oil have cooled to ambient temperature.
5. Remove the nuts from the two pins connecting the attachment.



6. Tap out the pins with a hammer, keeping them clean.



7. Start the engine, raise the boom, and remove the old attachment.

Mounting the Hammer

Tools Needed:

Flathead Screwdriver

Wood Blocks

Hoist or an Extra Couple of Hands

1. Park the excavator on level ground, lower the arm to a height that is easily accessible for mounting, and shut off the engine.
2. Wait until the engine and hydraulic oil have cooled to ambient temperature.
3. Remove the arm pin by detaching the fastening nut and bolt on the hammer, **DO NOT** move the pin flanges. Keep the nut and bolt nearby.

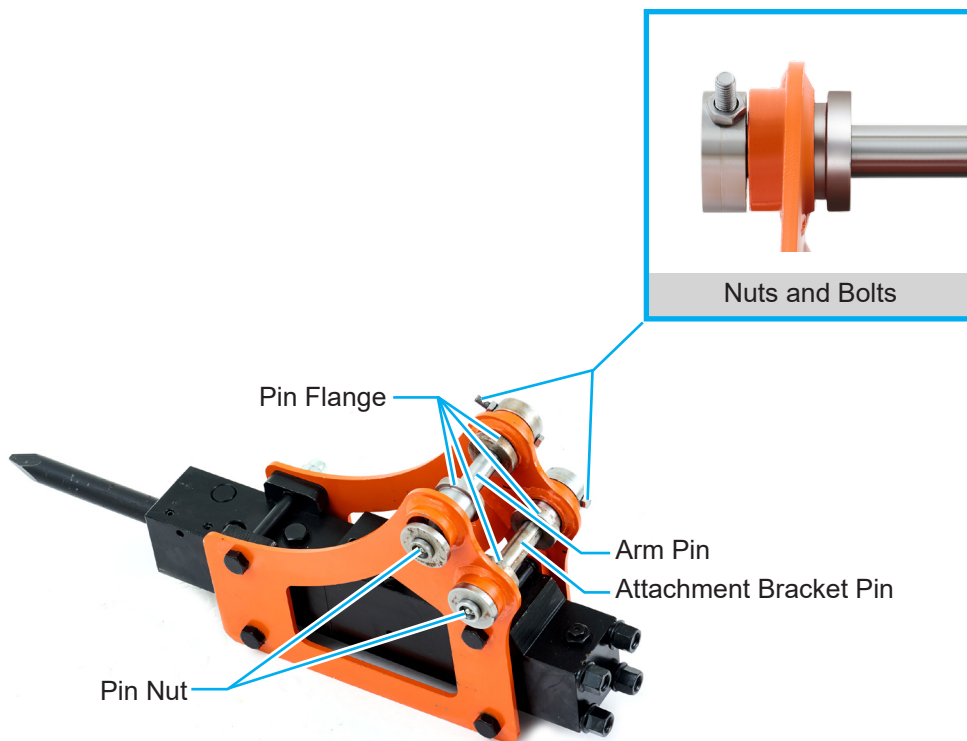

4. Repeat the same for the attachment bracket pin.
5. Lift the hammer to where its pin holes can align with the arm pin hole and the attachment pin hole by using a hoist or an extra couple of hands.

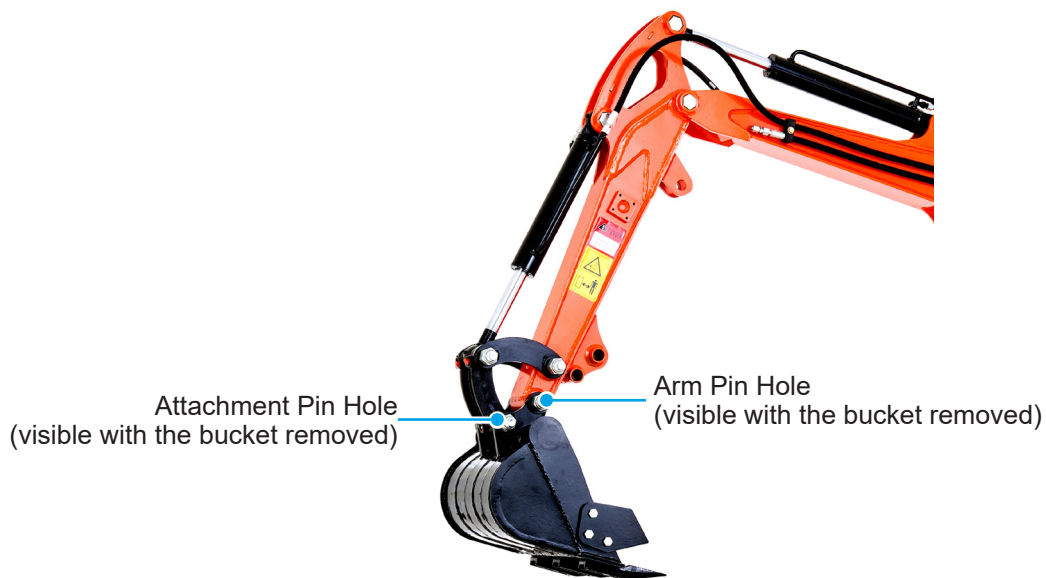

6. Align the arm pin hole with that on the excavator arm, feed the removed arm pin sequentially through the following:
 - a. the housing of the hammer
 - b. the pin flange
 - c. the arm
 - d. the other flange
 - e. the other side of the housing
7. Lock the pin with the removed bolt and nut.
8. Repeat steps 6–7 for the attachment bracket pin.

Connecting the Hydraulic Hoses

Check if your excavator has hydraulic valves, choose either of the following methods that suits you to connect the hydraulic hoses.

Caution

- Cover the exposed hydraulic ports and hose ends
- Position the hammer on the wood blocks so that the chisel is at a lower level than the nitrogen chamber. This prevents foreign matter such as moisture or fine debris from entering the hammer.
- **ALWAYS** wait till the hydraulic oil has cooled to ambient temperature.
- **ALWAYS** follow the protocols for using a hoist.

For Excavators with Hydraulic Valves



1. Shut off the engine.
2. Wait until the engine and hydraulic oil have cooled to ambient temperature.
3. Close the valves by turning them clockwise by 90° until its debossing is perpendicular to the arm.



4. On one side, remove the hose cap on the excavator hose end to expose the male port by turning the cap and holding the male port still.



Note: If the core of the hose cap remains stuck inside the male port, remove it with a pair of pliers. Store it with the removed hose cap.

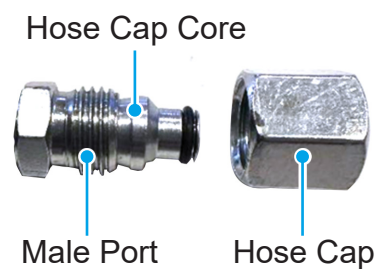

5. (Optional) If the male port on your excavator is not M16 but M14, convert the port to an M16 male port by replacing it with the provided M14×1.5 male to M16×1.5 male thread adapter.
6. Cover the hose end with plastic wrap (not included).
7. Repeat steps 4–6 for the other side.

8. Remove the caps on the hydraulic ports of the hammer with an adjustable wrench. Cover the exposed ports with plastic wrap.

Note: *Keep the caps in place. If the hydraulic hammer is to be detached for storage, they will do a better job protecting the cylinder than plastic wrap.*

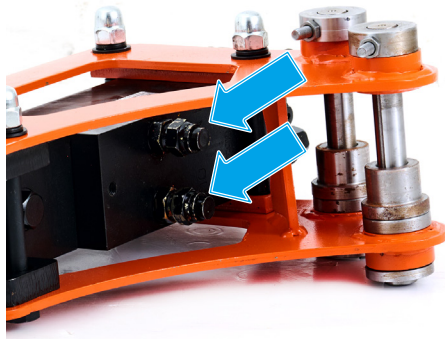

9. Having removed the plastic wrap around the **LEFT** port on the hydraulic hammer and the **LEFT** hose end on the excavator, connect the M14×1.5 end of the provided hose to the hammer, and the M16×1.5 end to the excavator hose end by hand turning.
10. Repeat similar steps for the **RIGHT** side.
11. Fasten each connection on both ends of the provided hoses with an adjustable wrench.
12. Open the valves by turning them counterclockwise by 90° until the debossing is parallel to the arm.
13. Test the excavator and make sure:
 - You can use the hammer smoothly.
 - No hydraulic oil is leaking from connections, if not, reconnect as needed.

For Excavators without Hydraulic Valves



1. Raise the boom so that it's slanted upward but still within reach.

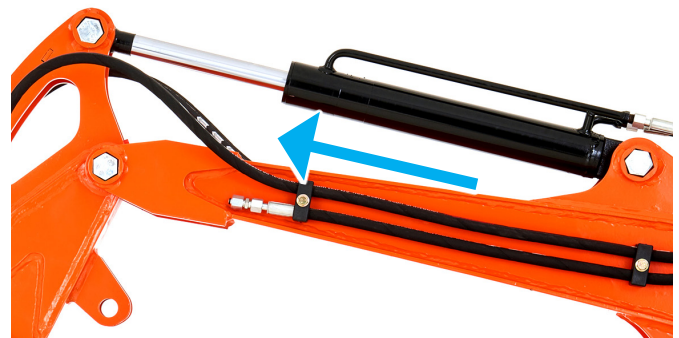

2. Shut off the engine.
3. Wait until the engine and hydraulic oil have cooled to ambient temperature.
4. On one side, remove the hose cap on the excavator hose end to expose the male port by turning the cap and holding the male port still.



Note: If the core of the hose cap remains stuck inside the male port, remove it with a pair of pliers. Store it with the removed hose cap.

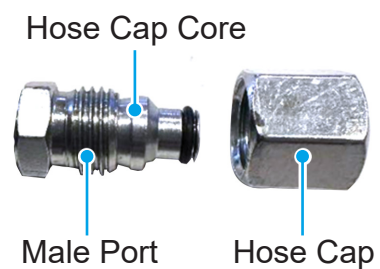

5. (Optional) If the male port on your excavator is not M16 but M14, convert the port to an M16 male port by replacing it with the provided M14×1.5 male to M16×1.5 male thread adapter.
6. Cover the hose end with plastic wrap (not included).
7. Repeat steps 4–6 for the other side.
8. Remove the caps on the hydraulic ports of the hammer with an adjustable wrench. Cover the exposed ports with plastic wrap.

Note: *Keep the caps in place. If the hydraulic hammer is to be detached for storage, they will do a better job protecting the cylinder than plastic wrap.*

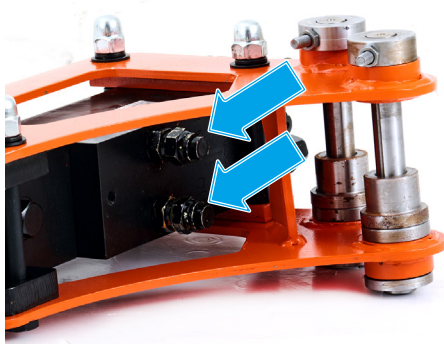

9. Having removed the plastic wrap around the **LEFT** port on the hydraulic hammer and the **LEFT** hose end on the excavator, connect the M14×1.5 end of the provided hose to the hammer, and the M16×1.5 end to the excavator hose end by hand turning.
10. Repeat similar steps for the **RIGHT** side.
11. Fasten each connection on both ends of the provided hoses with an adjustable wrench.
12. Open the valves by turning them counterclockwise by 90° until the debossing is parallel to the arm.
13. Test the excavator and make sure:
 - You can use the hammer smoothly.
 - No hydraulic oil is leaking from connections, if not, reconnect as needed.

Operation

Operational Safety Precautions

- **DO NOT** use the hammer as a hoist
This hammer is not designed for hoisting. Doing so could topple the excavator.

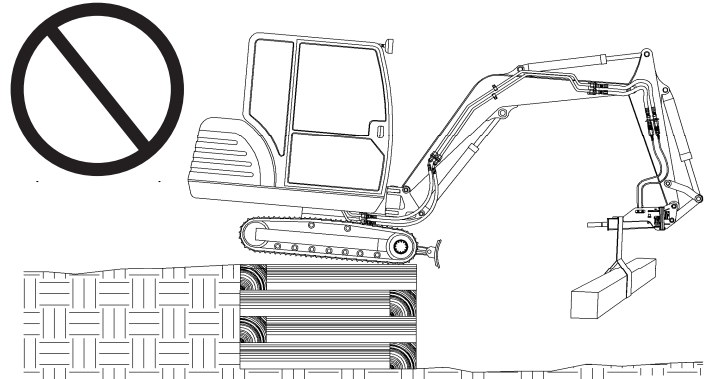

- Preload the chisel before activating the hammer.
Preloading the chisel means pressing its tip against the material to be demolished **BEFORE** activating the hammer.

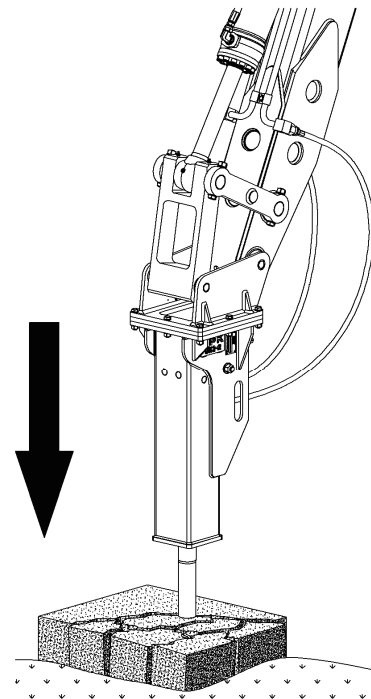

- **DO NOT** slant the hammer.
Slanting the hammer **WILL** cause the chisel to bend or even break.

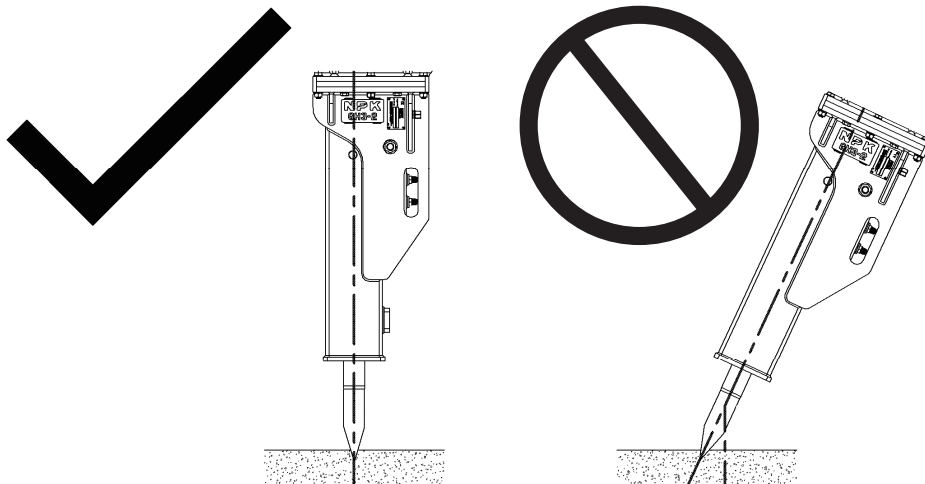

- Keep the boom direction of force in the same direction the chisel is penetrating. Use the boom cylinder to preload the hammer (apply down force), and use the arm cylinder for alignment. Keep the tool tangent to the arc of the boom.

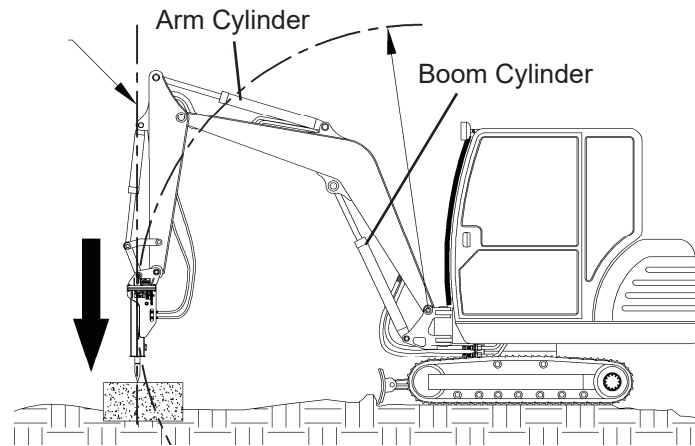

- Avoid blank hammering.

Blank hammering is continued hammer operation after the material has been shattered. This will overheat the hydraulic system, and eventually cause excess wear on the retaining pin.

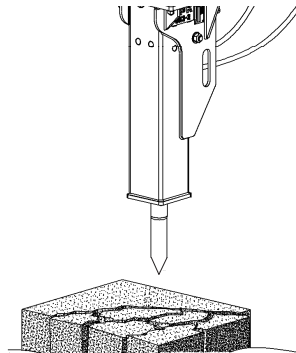

- Do not use the chisel as a pry bar.

Excessive prying can cause premature bushing wear and chisel contortion or even breakage. When hammering materials that allow the tool to penetrate before breaking, move the hammer slightly fore and aft to create a cone-shaped hole. The vented hole allows trapped dust and heat to escape, increases the tool penetration rate into the material, and prevents overheating the chisel tip.

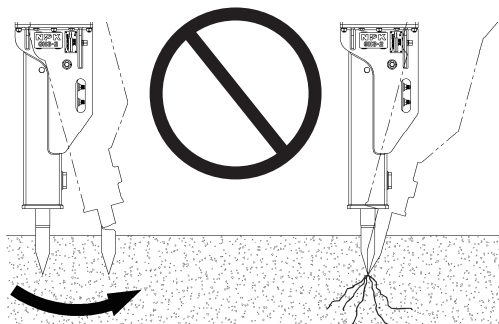

- Do not hammer continuously at the same spot for over 30 seconds.

If the hammer does not seem to penetrate the material after 30 seconds of constant percussion, choose another spot.

Hammering in the same position for a long time will reduce the working efficiency, increase the hydraulic oil temperature, overheat the chisel tip, and shortens its service life.

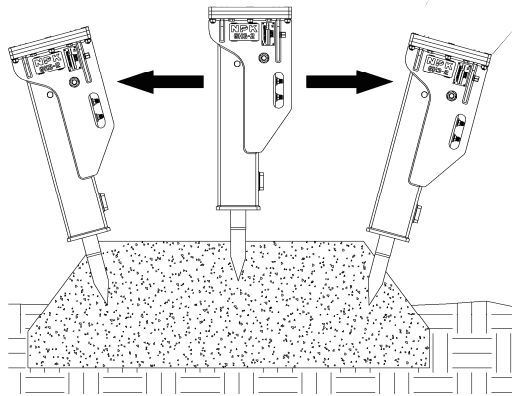

- Always start with a free face.

Start with a free face instead of the middle of a giant, reducing the risk of getting the chisel stuck.

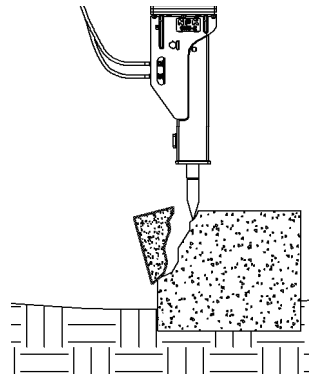

- **DO NOT** drop the hammer rapidly on an object.

While lowering the hammer to the material to be worked on, closely watch how fast it is descending.

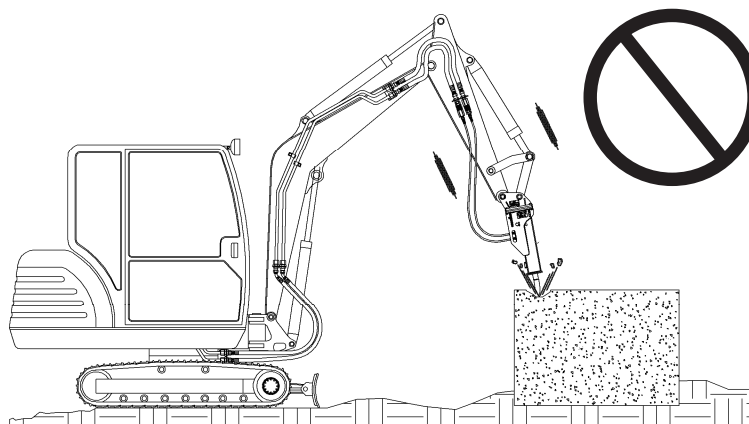

- **DO NOT** use the hammer to nudge large, heavy objects.
Doing so **WILL** cause off-centered wear on the arm pin and attachment pin.

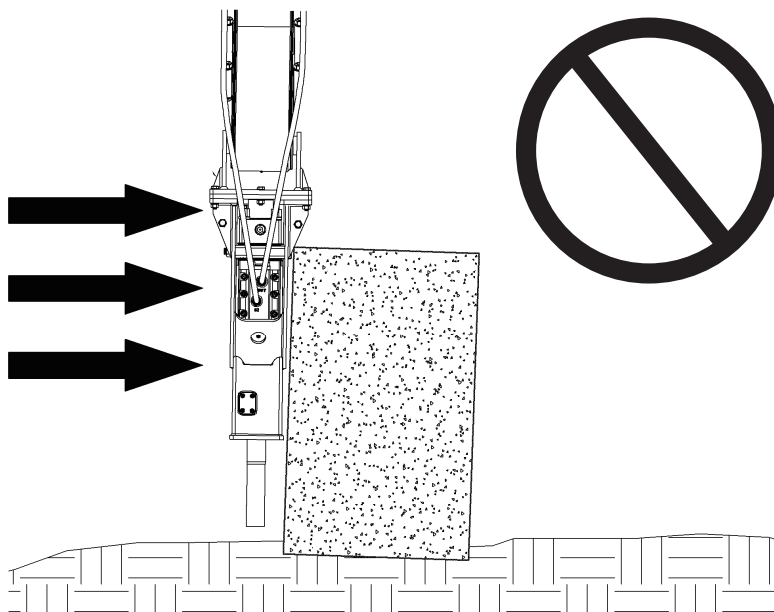

- **NEVER** over-extend or over-retract the cylinders.

Continuous and repeated over-extension and over-retraction of the cylinders can damage the cylinders.

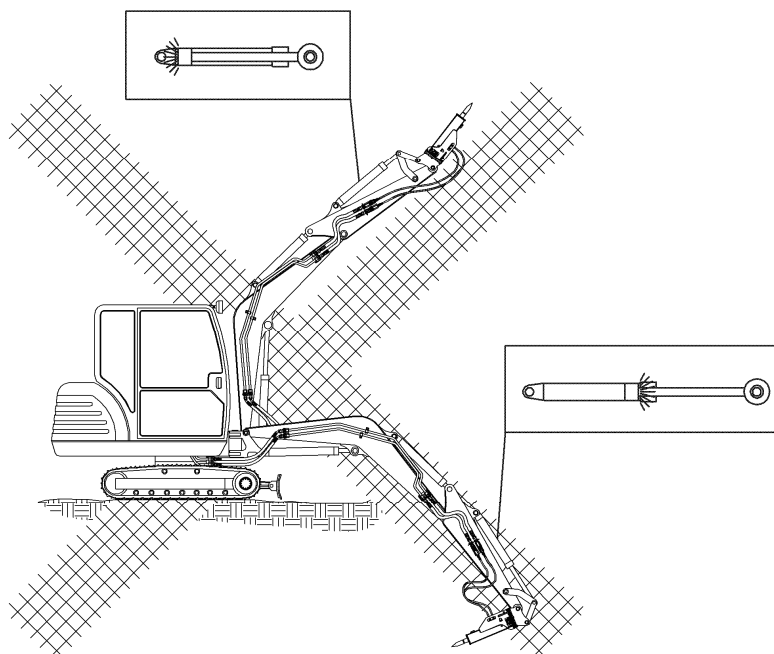

- **DO NOT** submerge any part other than the chisel under water.

The hammer is not watertight. Operated underwater, water **WILL** damage its inner components.

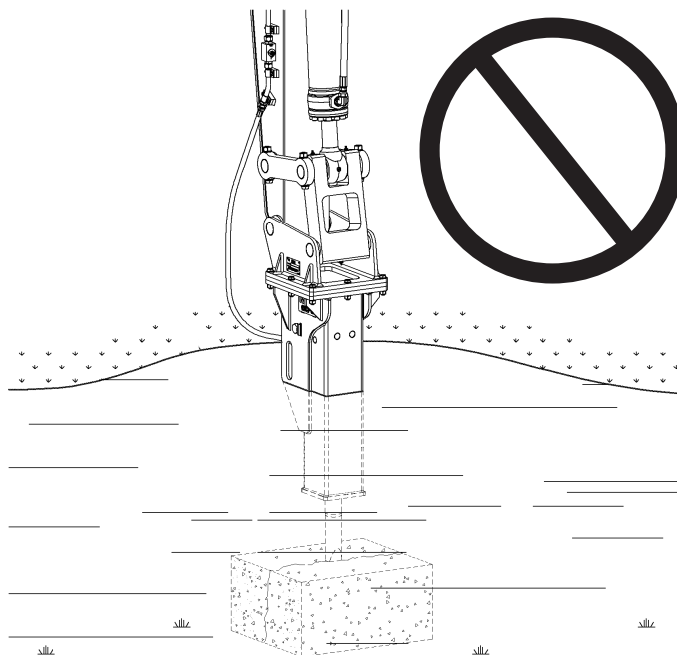

- **DO NOT** allow the hammer to hit the boom.

While tucking the hammer for transportation, watch out for where the chisel will be.

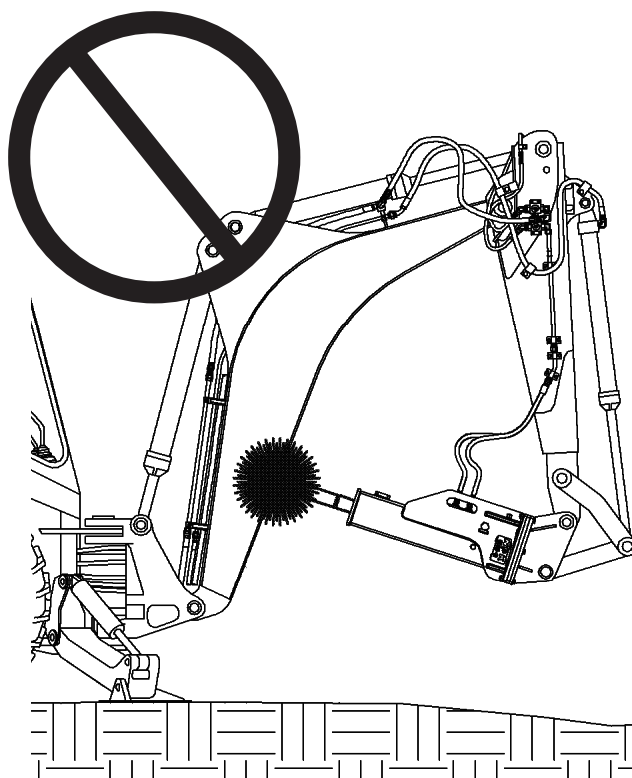

General Operation

Warning

Read and follow all the instructions in this chapter and all others stated in your excavator manual before operating.

1. Ensure that the hydraulic flow and pressure settings on the mini excavator match the specifications required by the hydraulic hammer.
2. Start the mini excavator's engine and allow it to warm up depending on the weather conditions.
3. Control the boom and arm to position the hydraulic hammer above the target area.
4. Preload the chisel by gently pressing its tip against the surface of the material to be shattered.
5. Engage the material by activating the hammer.

Caution

- *Keep the chisel perpendicular to the material during the shattering.*
 - *Apply force perpendicular to the material force.*
 - *The amount of pressure and force will vary depending on the job and material you are breaking.*
6. Once the material is broken, deactivate the hammer and lift the chisel out of the debris.
The amount of pressure and force will vary depending on the job and material you are breaking.

Maintenance

Replacing the Chisel

Warning

- **ONLY** replace a broken chisel with the provided spare.
- **ALWAYS** Lower the hammer to a level and sturdy ground.
- Shut the engine of the excavator **BEFORE** servicing the chisel. Inform bystanders and all personnel at the stake of the servicing underway. For the best result, stash away the ignition key to the excavator.
- Generally, a chisel needs to be replaced if the shown parts have chipping, breakage, crack, or contortion.

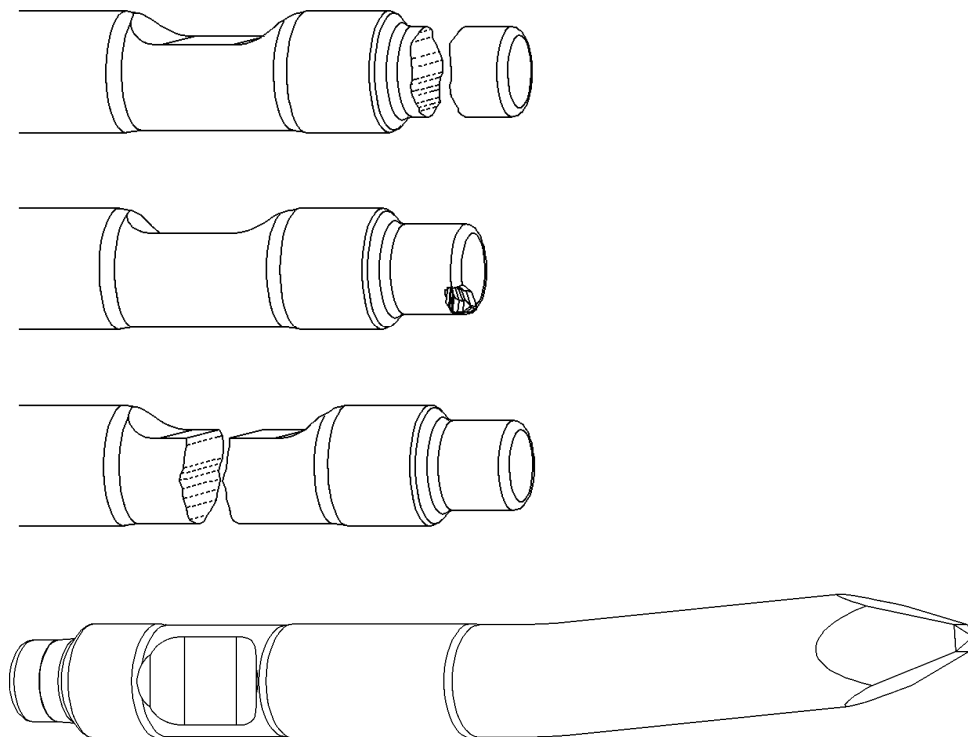

1. Detach the hammer assembly from your excavator by reversing the steps in installation.

2. Locate the retaining pin plug, located at the flank of the hammer near the chisel.

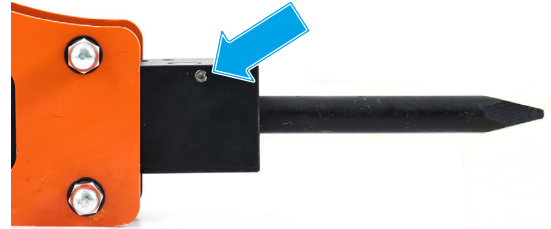

3. Aligning the retaining pin plug driver with the plug, strike the end of the driver with a hammer to force out the plug.

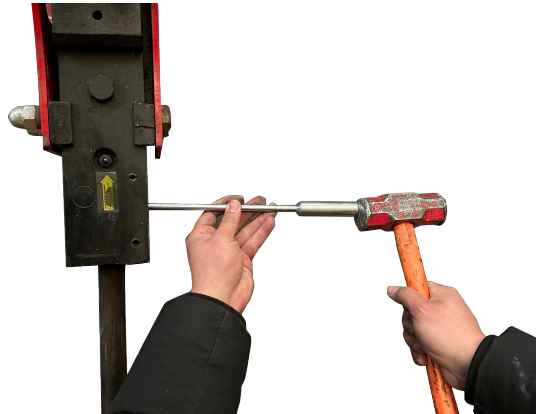

4. When the plug sticks out, pull it off the hammer assembly.

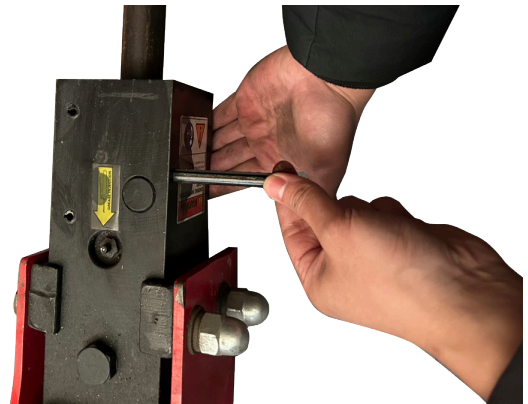

5. Remove the retaining pin. If it binds too tight, tap its housing with a rubber mallet.

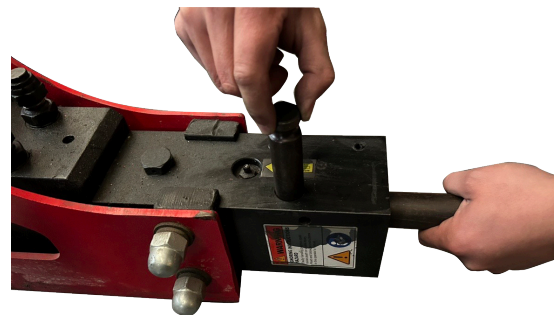

6. Remove the old broken chisel and insert a new identical one, making sure the indented end will face the retaining pin.



Note: If the indentation faces the other side, you won't be able to put back the retaining pin.

7. Replace the retaining pin, making sure it retains the chisel in place by pulling at the chisel.

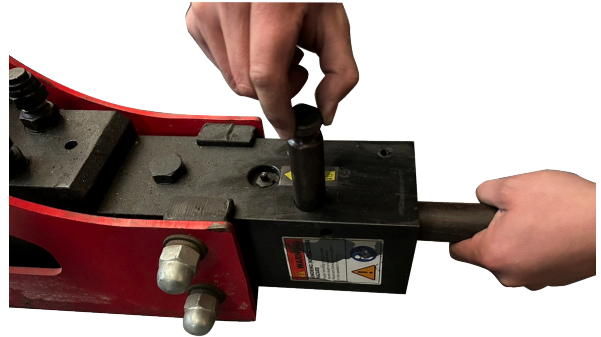

8. Replace the retaining pin plug and drive it in place with your hammer and plug driver.
9. Reattach the hammer to the arm if it will be needed.



Lubrication

Warning

- **ONLY** use *lithium grease to lubricate*. **NEVER** use *kerosene or other seemingly lubricative but highly flammable substances*.
- **ALWAYS** *Lower the hammer to a level and sturdy ground*.
- *Shut the engine of the excavator before greasing. Inform bystanders and all personnel at the stake of the servicing underway. For the best result, stash away the ignition key to the excavator.*
- *Lubricate the below components when the rotation has become difficult and gives a squeaky sound.*

1. Clean the greasing points of any grime or debris.
2. Lubricate the inside of the pin nut using lithium grease.

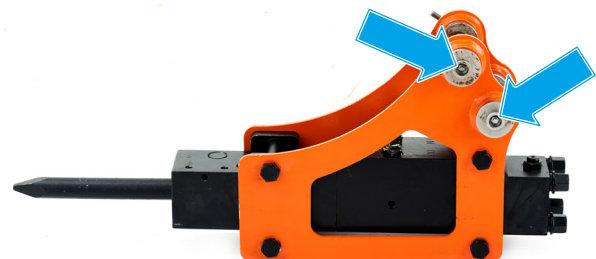

Recharging the Hammer

This hammer utilizes a cylinder structure designed to reduce recoil and increase impact efficiency. The cylinder's end contains a chamber filled with nitrogen, which helps to dampen the recoil of the chisel.

STOP the hammer immediately if any of the following signs occur and recharge it:

- When the hydraulic hoses jerk violently.
- If the percussive force of the chisel has significantly dwindled.

Continuing operation may lead to damage to both the excavator and the hydraulic hammer.

Warning

- *Stay clear of the chisel while charging the hammer. A sudden change of pressure in the chamber may cause the chisel to thrust out.*

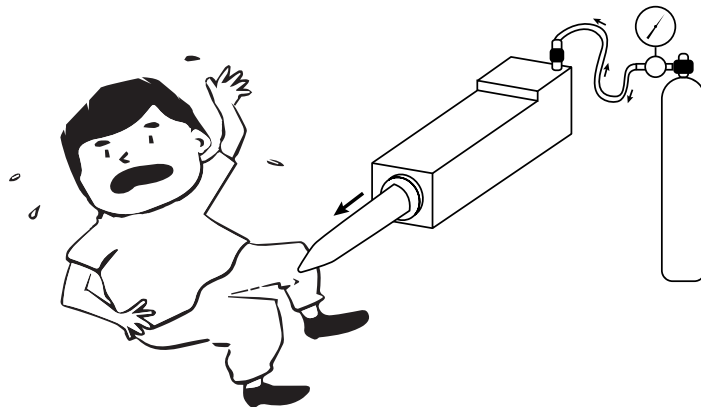

- **ONLY** charge the hammer to its required pressure (11–13 kg/cm³). An underpressurized or over-pressurized chamber risks shortening the service life, your work efficiency, and more serious injuries.
- **ONLY** use nitrogen gas! Store and handle nitrogen tanks per OSHA regulations.

1. Fill the nitrogen canister from a hydrogen fueling station until the pressure reaches 13–14 kg/cm² (185.1–199.1 psi).
2. Fetch the toolkit box, the tiny blue box containing the pressure gauge, the charge hose, and the nitrogen canister.



3. Attach the 5/8" port of the hose to the outlet port on the canister, tightening the connection.
4. Attach the other port of the hose to the intake port on the gauge, tightening the connection.



5. Remove the cap sealing the charge port of the hammer using the provided hex wrench. If the cap binds too tight, use an extension rod (not included) for extra leverage.

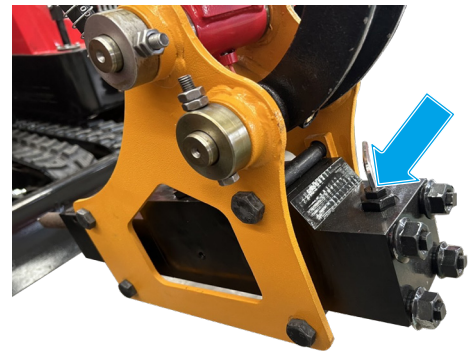

6. Fit the charge nozzle as shown into the charge port of the hammer, turning the nozzle knob to secure the nozzle in place.

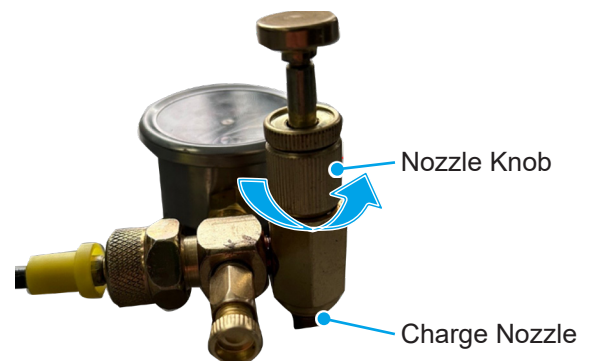

7. Having checked that the gauge valve is securely closed, pull up the nozzle lever to its limit.

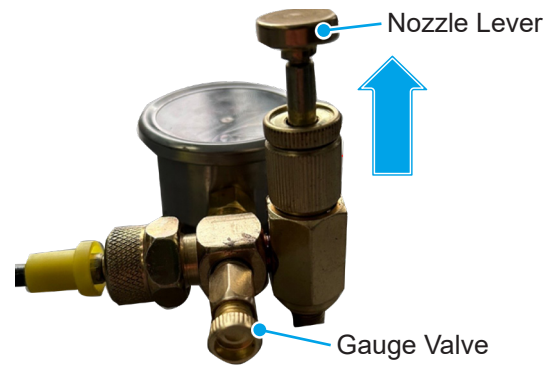

8. Gently turn open the valve on the nitrogen canister and close the valve in a second.

Note: Normally, the charging only takes 1 second, give or take a fraction of a second.



9. Slowly press the nozzle lever and check the reading on the gauge.
 - If the reading remains stable within 11–13 kg/cm², then the charging is finished.
 - If the reading exceeds 13 kg/cm²,
 - a. Gently press the nozzle lever.
 - b. While turning open the gauge valve, closely watch the reading change.
 - c. Close the valve when the reading has dropped within 11–13 kg/cm².



- If the reading is smaller than 11 kg/cm², repeat steps 7–8 until the required pressure is reached.
9. Remove the gauge from the hammer, replace and tighten the charge port cap, disassemble the gauge and canister, and stow everything away.