

# ELECTRIC BICYCLE USER MANUAL



Read Carefully Before Use  
Keep for Future Reference

# Disclaimer

Read this disclaimer **BEFORE** use.

## 1. **As-is**

This product(s) is sold 'as is' and without any express or implied warranties, including but not limited to the implied warranties of merchantability and fitness for a particular purpose.

## 2. **Product Modifications**

Any modifications or alterations to VIRIBUS products void any warranties and may result in damage or injury. VIRIBUS shall not be liable for any damages resulting from such modifications or alterations.

## 3. **Compliance with Laws**

Customers shall be liable for ensuring that the use of VIRIBUS products complies with all applicable laws and regulations in their respective jurisdictions. VIRIBUS assumes no responsibility for any violations of laws or regulations resulting from the use of its products.

## 4. **Correct Use**

Always use the product(s) only as directed in the accompanying manual. Failure to follow instructions may result in injury or damage.

Always ensure the operation, installment, maintenance, and repair of the product(s) is carried out by a competent person.

Always make maintenance regularly throughout the product lifecycle, you have the liability to keep the product operating as intended.

Always wear appropriate protective gear.

## 5. **Third-Party Products**

VIRIBUS shall not be liable for any damages or losses resulting from the use of third-party products in conjunction with our products. Customers should refer to the third-party's guidelines or/and warranties (if any) for any third-party products used.

## 6. **Limitation of Liability**

VIRIBUS shall not be liable for any direct, indirect, punitive, incidental, special, or consequential damages to property or life, whatsoever arising out of or connected with the use or misuse of our product(s). In no event shall VIRIBUS's liability exceed the value of the product(s) sold.

This disclaimer states the entire obligation of VIRIBUS with respect to the products. If any part of this disclaimer is determined to be void, invalid, unenforceable, or illegal, including, but not limited to the warranty disclaimers, liability disclaimers, and liability limitations set forth above, then the invalid or unenforceable provision will be deemed superseded by a valid, enforceable provision that most closely matches the intent of the original provision and the remainder of the agreement shall remain in full force and effect.

# CONTENTS

<b>Safety Information</b> .....	<b>1</b>
<b>Specifications</b> .....	<b>2</b>
<b>Product Diagram</b> .....	<b>3</b>
<b>Package List</b> .....	<b>5</b>
<b>Assembly</b> .....	<b>6</b>
Handlebars .....	6
Front Wheel.....	7
Front Fender and Light.....	7
Front Brake Caliper .....	8
Basket.....	8
Pedals.....	9
Saddle .....	10
<b>Operation</b> .....	<b>11</b>
Battery .....	11
Battery Capacity Levels.....	11
Removing/Installing the Battery.....	12
Charging .....	12
Activating and Deactivating the Display Panel .....	13
Pedal Assist Control .....	13
Throttle Control.....	14
Push Assist Control .....	14
Manual Control .....	14
<b>Adjustment</b> .....	<b>15</b>
<b>Maintenance</b> .....	<b>18</b>
<b>Troubleshooting</b> .....	<b>19</b>
General Instructions .....	19
Error Codes .....	21
<b>Disposal</b> .....	<b>22</b>

# Safety Information

## Warning!

- Assemble and adjust this bicycle **ONLY** in accordance with these instructions. Read them completely prior to assembly and use. Contact customer service if any point is unclear. Provide this manual to anyone who will use this bicycle and provide it with this bicycle (whether already assembled or not) if it is ever given or sold to a third party. Failure to follow these instructions may lead to serious personal injury and property damage, possibly including death.
- **ALWAYS** obey all applicable local and national laws and regulations while riding. Do not ride this bicycle in any area prohibited to electric bicycles. Always wear your helmet and other required protective gear. Always maintain your reflectors and other required safety equipment.
- Check whether the brakes function well using the brake levers **BEFORE** riding. Even after power is cut to the motor, the inertia of the bike will often require active braking power.
- **ALWAYS** ensure all fasteners and components are intact and securely tightened before and after every use.
- **DO NOT** ride this bicycle if any part is damaged or shows any sign of malfunction. Repair or replace worn and broken components before further use. Never replace any parts with nonidentical ones.
- **DO NOT** allow children or persons unfamiliar with this bicycle or these instructions to operate it. Do not ride it while you are tired or under the influence of drug or medication.
- **DO NOT** wear loose footwear or clothing that may become caught in the wheels or any other moving parts.
- Pay attention to your remaining power before setting out and during use. Recharge your battery as needed to ensure it never runs out of power at a moment where you are taken by surprise.
- It is recommended that you not ride your bike fast when getting started. This can be ensured by setting the bike's top speed low until you are fully familiar with your new electric bike and its controls.
- **ALWAYS** be alert for people, animals, or any obstacles that may appear in front of you while riding your bicycle. Be aware that pedestrians and drivers may not expect the speed or responsiveness of your bike. Adjust your behavior accordingly. It is advisable to install warning devices to draw their attention, but always be ready to turn safely out of their way if needed. Do not focus on the display panel for extended periods of time while riding.
- **NEVER** ride at a speed where your stopping distance exceeds your visibility. We do not recommend that you ride your bicycle at night or in an environment with poor visibility. If you have an emergency that makes it necessary to do so, keep your light on and limit your speed appropriately.
- **NEVER** use the throttle or pedal assist system (PAS) in any situation, road condition, or terrain where doing so might impair your control of your bicycle.
- **DO NOT** load this bicycle with more than 264 pounds (120 kilograms).
- **NEVER** adjust the 03, 06, 07, 13, 14, 15, or 16 parameters in the display menus. Adjustment of these parameters should only be made when using the display panel with other motorized wheels of differing voltage, diameter, or magnetic arrangement. In any other case, any adjustment of these parameters should be undone **IMMEDIATELY**. Restore the original settings before any further use of this bicycle.

- **ALWAYS** avoid direct pressurized spray that might allow the interior of the battery, display panel, front light, and other electronic components to become wet. If the interior of the battery accidentally becomes wet, replace it with a new identical one. For the other electronic parts, wait for them to completely dry before any further use.
- **ALWAYS** fully disconnect the battery from this bicycle between uses and before any cleaning, servicing, and storage.
- **NEVER** place the battery near heat sources or explosive or flammable gases. Never expose it to radiation or excessive pressure. Only charge the battery in locations with an ambient temperature between 32°F/0°C and 110°F/45°C.
- **NEVER** modify the battery or power cord. Only use the provided charger with this bicycle. Never get the charger or power cord wet or operate them with wet hands.
- If the battery is ever damaged, avoid all contact with it or any leaking fluid. Remove contaminated clothing and flush with copious amounts of water if contact accidentally occurs with the skin. If contact accidentally occurs with the eyes, **IMMEDIATELY** flush them with copious amounts of water for at least 15 minutes while seeking medical attention.

## Specifications

<b>Motor Power</b>		500 W	
<b>Wheel Diameter</b>		26 in. ("06"=26)	66 cm
<b>Magnet Arrangement</b>	<b>Speed Sensor</b>	1 Alnico Magnet ("07"=001)	
	<b>Pedal Assist Sensor</b>	5 Alnico Magnets ("13"=05)	
<b>Battery</b>	<b>Type</b>	48V Lithium ("03"=48)	
	<b>Weatherproofing</b>	IPX4	
	<b>Operational Temp. Range</b>	-4 to 104°F	-20 to 40°C
	<b>Charging Temp. Range</b>	32 to 110°F	0 to 45°C
	<b>Optimal Storage Temp. Range</b>	32 to 104°F	0 to 40°C
<b>Display Panel</b>	<b>Weatherproofing</b>	IPX7	
<b>Front Light</b>	<b>Weatherproofing</b>	IPX5	
<b>Control Hardware</b>	<b>Current Limit</b>	15 A ("14"=015)	
	<b>Undervoltage Lockout</b>	39 V	
<b>Est. Operational Range</b>	<b>Throttle Control</b>	25 mi.*	40 km*
	<b>PAS Control</b>	45 mi.*	75 km*
<b>Max. Speed</b>		20 mph**	32 km/h**
<b>Weight Capacity</b>		264 lb.	120 kg

\* Based on a 154 lb. or 70 kg load at full power and at full legal speed on actual roads.

\*\* Based on unloaded wheel rotation at full power without friction with software limitations. True speed will vary according to variables such as battery strength and load but should remain within ±1 mph of the displayed speed.

# Product Diagram



## Handlebars

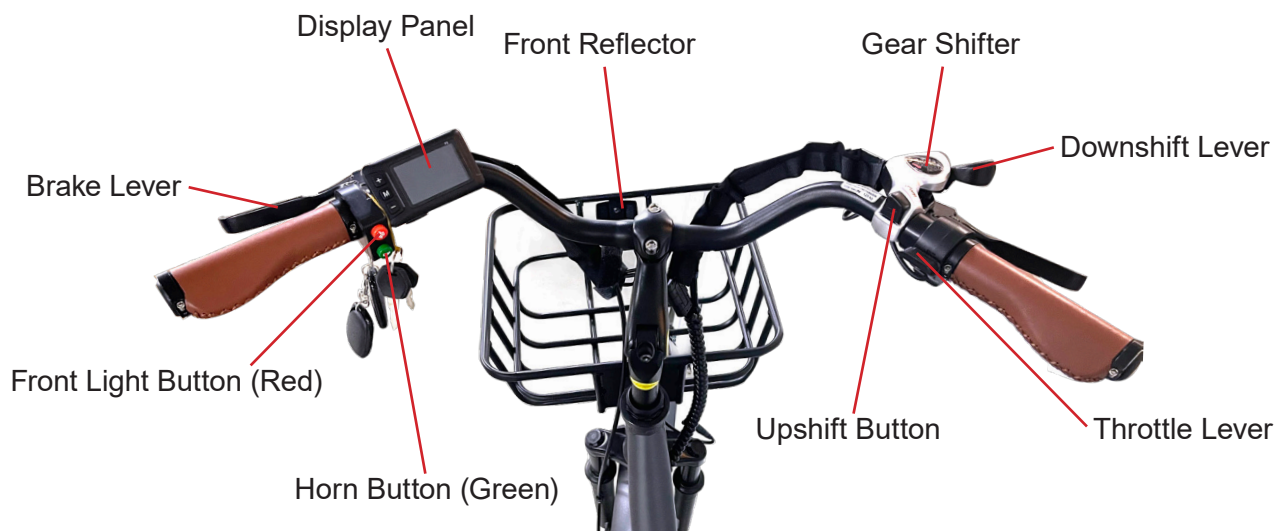

## Display Panel



### Buttons

- +** Increases the pedal assist level or toggles values up
- M** Toggles the variable display when pressed. Turns the display panel on and off when held
- Decreases the pedal assist level, turns off the motor, or toggles values down when pressed. Turns the push assist on and off when held

### Display

The top left corner displays when the average speed is displayed (AVG), when the maximum speed is displayed (MAX), when the front light is on (☰), when push assist is active (🚲), or when various errors occur: motor error (Ⓜ), brake error (⚠), throttle error (🔧), control hardware error (🔌), and undervoltage lockout (🔋).

The battery display shows your remaining battery power level.

The number on the middle left is the current speed in mph or km/h.

The number below “PAS” is the current pedal assist level.

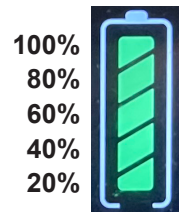

The number at the bottom is a variable display that may show your battery’s voltage (TIVOL), your current trip distance (TRIP), and your total distance traveled (ODO).



### Anti-Theft Alarm Controller

The bicycle is equipped with an anti-theft alarm system. When it is enabled, the alarm sound goes off and the front light turns on by themselves once any part of the bike is touched. The alarm can also be activated manually with either of the provided controllers, helping you find your bike in cluttered or dark areas.



-  Disables the alarm
-  Activates the alarm when pressed twice
-  Enables the alarm

# Package List

When you first get your new electric bike, carefully unpack all of the following components and accessories. Check that nothing is missing or has been damaged in transit. Keep children away from the packaging or provide constant supervision. Storing your original packaging through the warranty period will speed returns if any are needed.

Item	Name	Qty.
1	Main Frame with Motorized Rear Wheel, Control Hardware, Battery, & Chain	1
2	Handlebars with Display Panel, Throttle, & Gear Shifter	1
3	Front Wheel with Brake Disc	1
4	Front Brake Caliper	1
5	Saddle	1
6	Front Light	1
7	Front Fender	1
8	Pedals	2
9	48V Battery	1
10	Charger	1
11	Power Cord	1
12	Basket	1
13	Basket Mounting Kit (4×Hex Bolts & Washers)	1
14	Keys	2
15	Anti-Theft Alarm Controllers with CR2032 3V Lithium Coin Batteries	2
16	M5 Hex Wrench	1
17	M6 Hex Wrench	1
18	8×10mm Wrench	1
19	13×15mm Wrench	1
20	Phillips Screwdriver	1

**Not Included but Recommended:** Bike Stand



# Assembly

To see these instructions in video form, go to our YouTube channel **Viribus Bikes** and search for “Viribus Electric Bicycle with Front Basket, RBE-F2”.



It is recommended to wear hand protection and other PPE necessary for your work during assembly.



**DO NOT** use the keys during assembly. Complete assembly before activating the battery.

## Installing the Handlebars

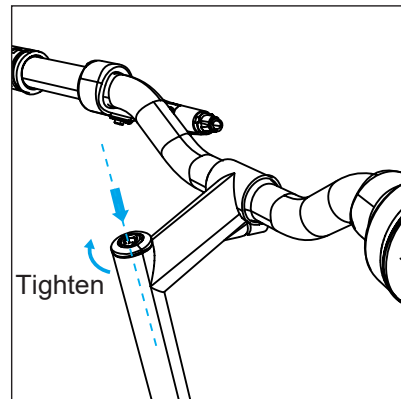
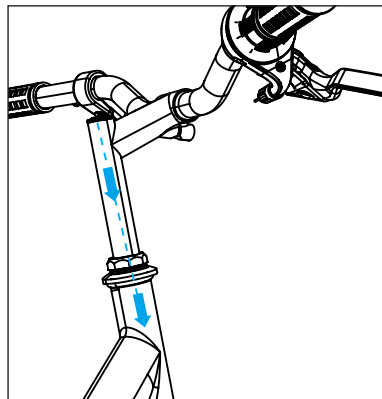
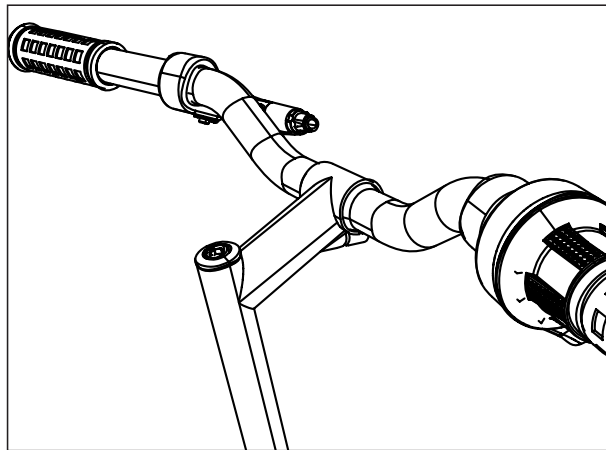

1. Place the main frame with the preinstalled motorized rear wheel vertically on firm level ground. For best results, secure them with a bike stand or similar device (not included).
2. Rotate the front fork until it stands perpendicular to the down tube.
3. Fit the handlebars into place on the head tube, rotating until they become perpendicular to the down tube.
4. Tighten the central top bolt using the M6 hex wrench until the handlebars are locked in place.

## Installing the Front Wheel

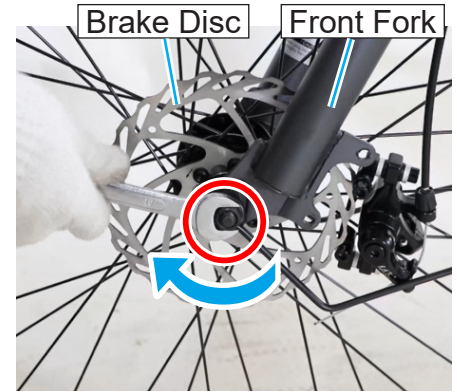
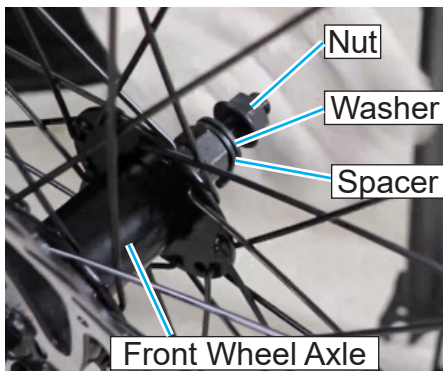

1. Remove the nuts on the front fork's tips using the 13×15mm wrench and disconnect the protective bar from the fork.
2. Remove the nuts and washers from both sides of the front wheel axle. Place them nearby.
3. Fit the front wheel into the front fork, placing the preinstalled front brake disc at the left side and allowing its axle to be snugly held.
4. Position the front fender behind the wheel on the surface you are working on and then fit its stay onto the spacer and wheel axle at either side, adjusting its shape if needed.
5. Replace one set of washer and nut to this side of the axle, partially tightening the nut by hand.
6. Align the slots at the other side and replace the remaining fasteners.
7. Tighten both of the nuts completely with the 13×15mm wrench to lock everything above in place.

## Installing the Front Fender and Light



1. Remove the nut and bolt from the support frame in front of the front fork.
2. Fit the front fender and light onto the frame, aligning their slots and replacing the bolt and nut.
3. Tighten the bolt with the M5 hex wrench and the nut with the 8×10mm wrench.

## Installing the Front Brake Caliper

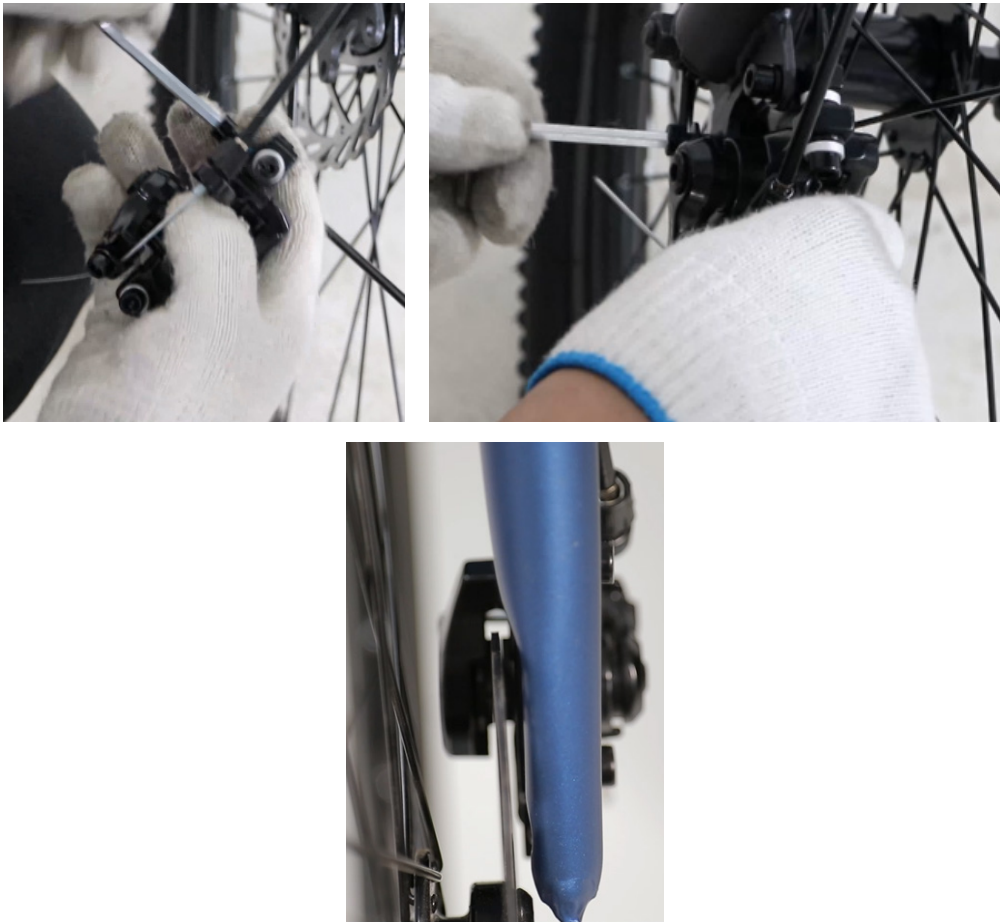

1. Remove the two bolts from the front brake caliper using the M5 hex wrench. Place them nearby.
2. Fit the caliper onto its holder at the left side of the front fork, ensuring that the front brake disc is well fitted into the slot on the caliper.
3. Replace and tighten the removed bolts to secure the caliper in place.
4. Test that the brake levers and brakes work smoothly and firmly before continuing.

## Installing the Basket

1. Place the basket onto its holder in front of the head tube.
2. Align the slots and attach the provided washers and hex bolts.
3. Tighten the bolts with the M5 hex wrench until the basket is locked in place.

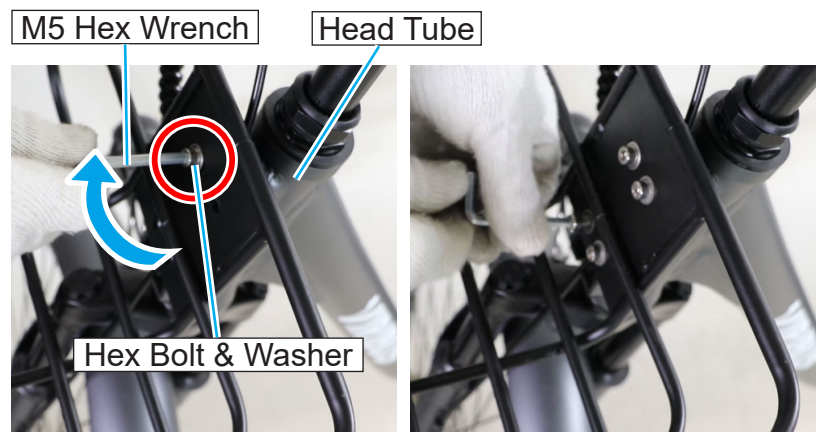

## Installing the Pedals

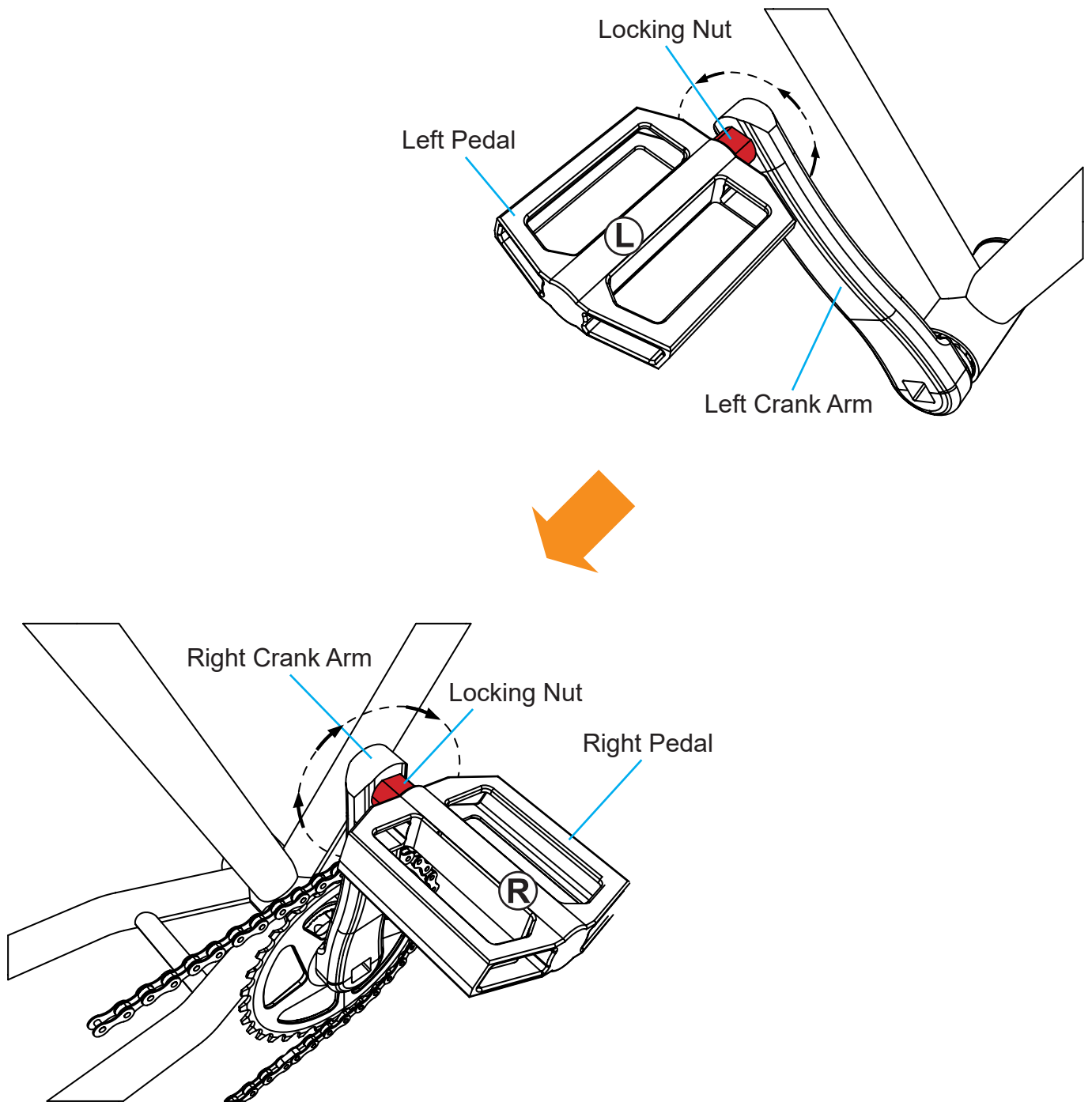

1. Identify the separate pedals, which **ARE** different and should **NOT** be mixed up. The left pedal is marked with an **L** and the right with an **R**.
2. Attach each pedal to the appropriate crank arm, screwing each into place.
3. Tighten the pedals' locking nuts with the 13×15mm wrench.
4. Test that the pedals are securely fastened and rotate freely.

## Installing the Saddle

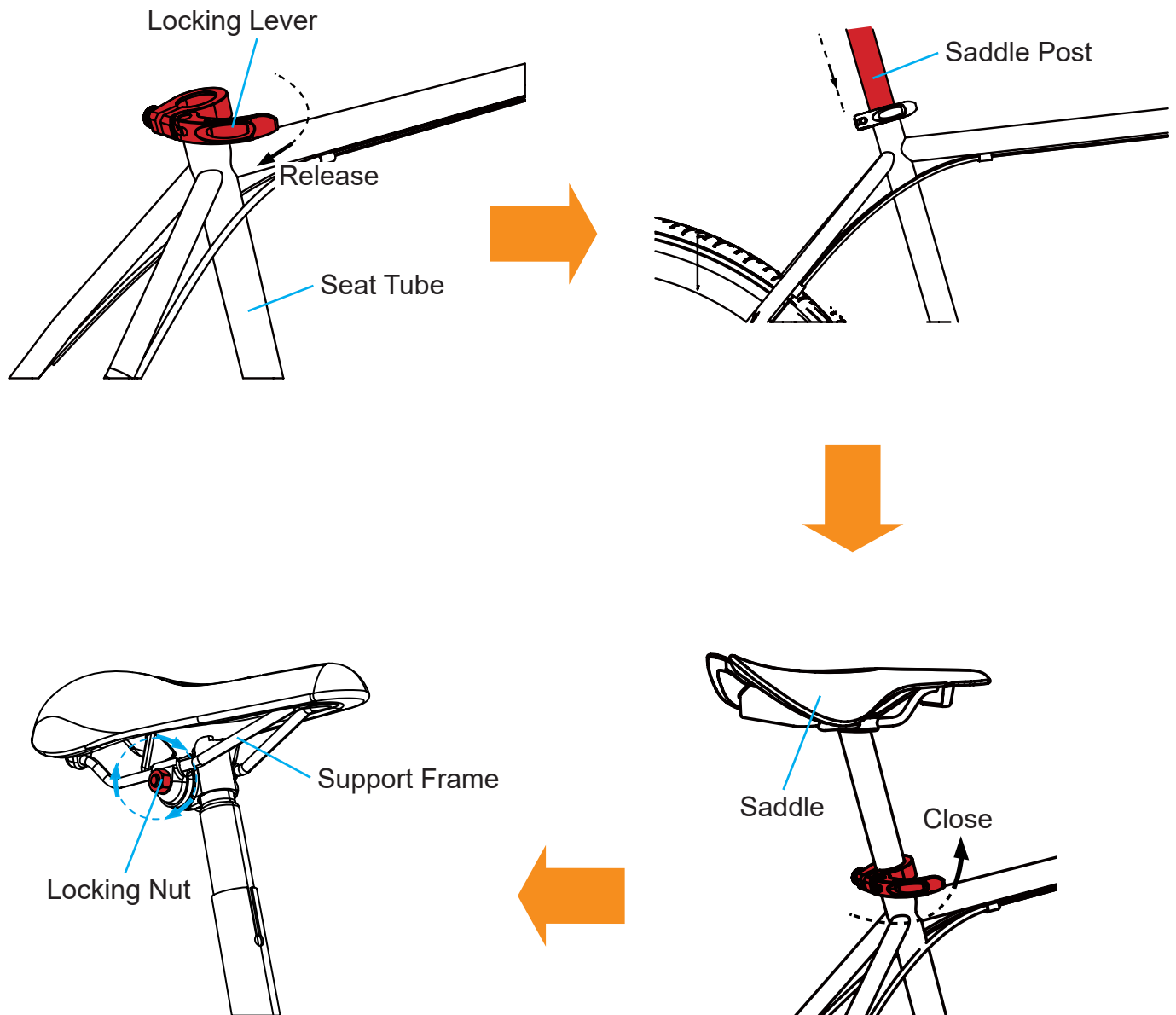

1. Release the locking lever on the seat tube of the main frame.
2. Insert the saddle post into the seat tube until your preferred height is reached.
3. Close the lever to lock the saddle in place.
4. To adjust the saddle forward or backward, loosen the two nuts underneath the saddle using the 13×15mm wrench, slide the saddle on its support frame until your desired position is reached, and retighten the nuts. Confirm they hold tight and the saddle does not show any wobble.

# Operation

 Your battery was charged at the factory but may have run down during shipping. Check the battery's remaining power for the first use and refill it using the provided charger as described in the Charging section below. If charging fails, reinstall the battery onto your bike, secure it in place with its motorized rear wheel raised, run the motor using the throttle lever as described below for a while, stop the motor, disconnect the battery, and restart charging.

 Between uses, always fully remove the battery to prevent unauthorized use.

## Battery

### Caution

***DO NOT** allow the battery to ever drain completely, which may reduce its lifespan and even make it hard to reactivate.*

## Battery Capacity Levels

In addition to the handlebar display, your bicycle's current power level can be checked on the battery itself.

To check the battery's current power level:

1. Insert one key (14) into the socket at the left side of the battery.
2. Turn the key clockwise to **ON**.

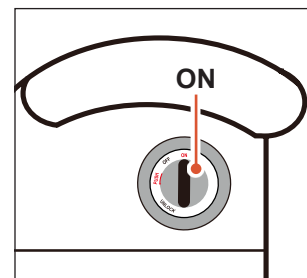

3. Press the power display button to see how many of the battery's indicator lights turn on.

4 lights indicate a full battery, while 1 light indicates a weak one.

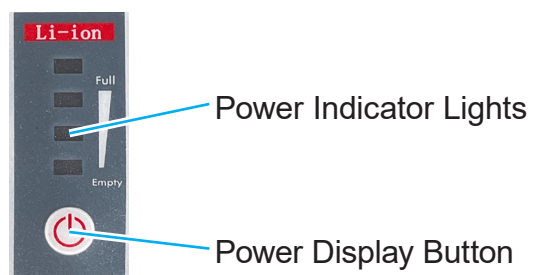

## Removing/Installing the Battery

To remove the battery from the bicycle, follow the steps below. To install the battery, simply reverse the process.

1. Push in the key, turning it counterclockwise to **UNLOCK**.



2. Push up the locking lever, raising the rear of the saddle.
3. Hold the handle at the top of the battery, lifting the battery away from the bike.



## Charging

When you find that recharging is necessary:

1. Connect the charger (10) to the battery's charging port using its DC cord.
2. Connect the power cord (11) to this charger's power inlet and your power source.  
The charger's power indicator light should turn red and charging begin.
3. Periodically check the battery's state and wait until the charger's indicator light turns **green**.
4. When finished, disconnect the power cord from power and then the charger from the battery.

Remember to properly insert the battery into the holder and then replace the saddle if you have taken it out.

### **Warning**

**DO NOT** leave the battery connected to power once it is already fully charged.

Overcharging can cause the battery to overheat, which may result in decreased performance or **EVEN** fires or explosions.

**Note:** In the event that charging fails, refer to **General Instructions in Troubleshooting on Page 19**.

## Activating and Deactivating the Display Panel

1. Ensuring that the battery is on, hold **M** until the display panel activates.

**Note:** *ALWAYS perform this before using the throttle or pedal/push assist control.*

2. To deactivate the panel, hold **M** again until its screen shuts down.

### Warning

*Simply deactivating the battery can also directly turn off the display panel. **HOWEVER**, this abrupt cut of power is **NOT** recommended and risks damaging the bicycle's components and circuits.*

## Pedal Assist Control

The pedal assist system (PAS) requires you to continue using the pedals to keep the motor active but provides additional speed and strength as you ride. By default, the PAS has five levels and a 20 mph or 32 km/h top speed. This top speed can be adjusted. If it is, the lower levels will run at 93.7%, 78%, 62.5%, and 46% of the new top speed.

Level	0	1	2	3	4	5
Speed	—	9 mph	12.4 mph	15.5 mph	18.6 mph	20 mph
	—	15 km/h	20 km/h	25 km/h	30 km/h	32 km/h
	0%	46%	62.5%	78%	93.7%	100%

The PAS can also be adjusted to use three levels instead.

Level	0	1	2	3
Speed	—	9 mph	15.5 mph	20 mph
	—	15 km/h	25 km/h	32 km/h
	0%	46%	78%	100%

By default, the PAS is activated at Level 1 as soon as the display panel turns on. The bike will accelerate to the speed of the current level (9 mph or 15 km/h) as soon as the pedals fully turn two times. Press **+** to go up one level. Press **-** to go down one level.

The PAS automatically pauses and the motor temporarily shifts to neutral in the following cases:

- You stop pedaling
- You press either brake lever
- Your bike accelerates on a slope to a speed faster than the top speed.

The PAS reactivates at its current level once both brakes are released, your speed is at or below the current target, and you resume pedaling. Going from Level 1 to 0 also disables the PAS and puts the motor in neutral until **+** is pressed, restarting PAS at Level 1.

If you press the throttle lever while PAS is active, the bike will activate throttle control and accelerate to its top speed. If you turn off the display panel while PAS is active, the motor will stop and the bike will only operate manually.



## Throttle Control

The electric bicycle can work as a single-speed scooter using the throttle lever on the right handlebar. By default, throttle control operates at the bike's preset top speed (20 mph or 32 km/h) and is available whenever the display panel is on. Press the throttle lever, stop pedaling the bike, and your bike will continue along at the top speed. Note that the top speed can be adjusted and some jurisdictions may require throttle control to be disabled on electric bikes. (See Parameters 08 and 10 in the Adjustment section below.)



Throttle control automatically pauses and the motor temporarily shifts to neutral in the following cases:

- You release the throttle lever completely
- You press either brake lever
- You accelerate beyond the top speed
- You disable the throttle, even without releasing the throttle lever

The motor will resume working once the throttle lever is pressed again, both brake levers are released, and your speed is at or below the top speed.

If you begin pedaling while throttle control is active, the bicycle will activate PAS control. If you turn off the display panel while throttle control is active, the motor will stop and the bike will only operate manually.

## Push Assist Control

The push assist system provides additional strength as you push the bicycle for a walk or climb. After the display panel is turned on, stand beside the bike, holding – until  is displayed, and then push your bike forward, which will cause the motor to activate at a speed of 3.7 mph or 6 km/h. Holding – again until  disappears or pressing either brake lever will cease the operation of push assist control.

You can also activate push assist control by adjusting the bike's top speed to 0 and holding the throttle down. Release to stop and adjust the top speed back to 1 or above to deactivate the option. (See Parameter 08 in the Adjustment section below.)

## Manual Control

To ride your bicycle normally, leave the display panel or battery turned off or remove the battery. (See the Charging section below for how to do so.) You can also ride normally with the display panel turned on by pressing – until the motor is put to neutral (“0”).

The Shimano thumb shifter uses a lever and a button to control the 7 rear cogs, providing 7-speed gearing for manual riding. The larger numbers represent the smallest cogs and the smaller numbers refer to the largest cogs. Press the + button at the base of the shifter to upshift and push the lever beside the shifter away to downshift.



Be sure your bicycle's crank is turning while using the shifter to adjust the chain.

If you press + while the display panel is on, the bike will activate PAS control at Level 1. If you press the throttle lever while the display panel is on, the bike will activate throttle control and accelerate to its top speed.

# Adjustment

To adjust the bike's parameters, hold **M** until the display panel turns on and hold **+** and **-** simultaneously to enter the adjustment menus. You will automatically start with Parameter 01 (Display Brightness). For each parameter, use **+** and **-** to change the settings and press **M** to save your changes and move to the next parameter. Hold **+** and **-** simultaneously again or wait for the display to automatically reset to leave the adjustment menus, saving all current changes.

## **WARNING!**

**DO NOT** adjust parameters 03, 06, 07, 13, 14, 15, or 16 while using this display panel with this bike. Parameters 03, 14, and 15 concern details of the electricity coming from the main battery. Parameter 06 allows adjustment of the compatible wheel diameter. Parameters 07 and 13 concern the arrangement of magnets within your motorized wheel and on your PAS sensor. Parameter 16 only applies to motorized wheels equipped with cruise control. These can be used to modify the display panel to work with other motorized bicycles but changing any of these values during use with this bicycle **WILL** cause it to perform abnormally, malfunction, and/or break. If such adjustment happens accidentally, stop the bike **IMMEDIATELY** and **IMMEDIATELY** correct the settings.

Parameter	Value
03	48
06	26.0
07	001
13	05
14	015
15	—
16	000

## 01 Display Brightness

Press **+** and **-** to adjust the brightness of the display panel. Using the minimum setting that is clearly visible affects your battery life a very little bit but more importantly allows your eyes to go between the road and the display with less readjustment in low light conditions. Setting 001 is dim, 002 is medium, and 003 is bright.

## 02 Measurement Units

By default, speeds and distances are displayed in US/English customary units (miles and mph). Press **+** and **-** to toggle between this and metric (km and km/h). Setting 000 is metric and 001 is US.

## 03 Battery Voltage

Never adjust this value. If it is ever changed by accident, stop the bike and reset it to 48 before continuing on your way.

## 04 Timed Shutoff

By default, your display panel and motor will automatically shut off once your bike has stopped moving for 10 minutes (Setting 010). Press + and – to adjust the number of minutes before the display shuts down between 001 and 060. Decreasing this setting to 000 disables the timed shutoff, putting your display panel and motor in standby mode indefinitely when you park your bike.

## 05 Power Levels

By default, your PAS operates with 5 power levels (46/62.5/78/93.7/100%) and can be downshifted to Level 0 (neutral mode). Press + to toggle between this and 3 levels (46/78/100%). Press – once to disable Level 0 and twice to restore it. Settings 05 and 09 activate 5 levels of operation and enable Level 0 while Settings 15 and 19 activate 5 levels but disable Level 0; Setting 03 activates 3 levels and enables Level 0 while Setting 13 activates 3 levels but disables Level 0.

## 06 Wheel Diameter

Never adjust this value. If it is ever changed by accident, stop the bike and reset it to 26.0 before continuing on your way.

## 07 Speed Sensor(s)

Never adjust this value. If it is ever changed by accident, stop the bike and reset it to 001 before continuing on your way.

## 08 Top Speed

By default, your motor has a top speed of 20 mph or 32 km/h. While in 5-level mode (See “05” above), press + and – to adjust this value. While using US customary units (see “02” above), the speeds will vary as shown:

Value	1–10	11	12	13	14	15	16	17	18	19	≥20
Level 1 (mph)	4.6	5.1	5.5	6	6.4	6.9	7.4	7.8	8.3	8.7	9
Level 2 (mph)	6.3	6.9	7.5	8.1	8.7	9.4	10	10.6	11.3	11.9	12.4
Level 3 (mph)	7.8	8.8	9.4	10.1	11.1	11.7	12.5	13.3	14.2	14.8	15.5
Level 4 (mph)	9.4	10.3	11.2	12.2	13.1	14.1	15	15.9	16.9	17.8	18.6
Level 5 (mph)	10	11	12	13	14	15	16	17	18	19	20

While using metric units (see “02” above), the speeds will vary as shown:

Value	1–16	17	18	19	20	21	22	23	24	25	26	27	28	29	30	31	≥32
Level 1 (km/h)	7.4	7.8	8.3	6.4	9.2	9.7	10.1	10.6	11	11.5	12	12.4	12.9	13.3	13.8	14.3	15
Level 2 (km/h)	10	10.6	11.3	11.9	12.5	13.1	13.8	14.4	15	15.6	16.3	16.9	17.5	18.1	18.8	19.4	20
Level 3 (km/h)	12.5	13.3	14	14.8	15.6	16.4	17.2	17.9	18.7	19.5	20.3	21.1	21.8	22.6	23.4	24.1	25
Level 4 (km/h)	15	15.9	16.9	17.8	18.7	19.7	20.6	21.6	22.5	23.4	24.4	25.3	26.2	27.2	28.1	29	30
Level 5 (km/h)	16	17	18	19	20	21	22	23	24	25	26	27	28	29	30	31	32

Adjusting this value to 0 enables push assist control. Hold the throttle down to activate it, release to deactivate, and set this valve to 1 or above to disable it again.

## **09 Throttle Start**

By default, the throttle lever instantly activates the bike's single-speed run. Press + and – to toggle between this and requiring two full rotations of the pedals before throttle control activates. Setting 000 activates instant throttle response and 001 activates a two-rotation start.

## **10 PAS or Throttle Disablement**

By default, your bike offers manual, the PAS, and throttle control as explained above. Press + and – to toggle among this, enabling the PAS only, and enabling throttle control only. Setting 000 disables throttle control. Setting 001 disables PAS control. Setting 002 reactivates both. (To disable both PAS and throttle control, simply leave your battery off or turn off the display panel while riding.)

## **11 PAS Sensitivity**

By default, your bike activates its pedal assist system when you turn the pedals two full rotations while the display panel is on. Press + and – to adjust how quickly you need to turn the pedals to activate the PAS. Lower values require less pedaling and higher values more.

## **12 PAS Acceleration**

By default, your bike ramps up the pedal assist speed for its current level smoothly and evenly. Press + and – to fine tune this acceleration to suit your riding style. Lower values accelerate more gradually and higher values more quickly.

## **13 PAS Sensor**

Never adjust this value. If it is ever changed by accident, stop the bike and reset it to 05 before continuing on your way.

## **14 Maximum Current**

Never adjust this value. If it is ever changed by accident, stop the bike and reset it to 015 before continuing on your way.

## **15 Minimum Voltage**

Never adjust this value. If it is ever changed by accident, stop the bike and reset it to no numbers before continuing on your way.

## **16 Cruise Control**

Never adjust this value. If it is ever changed by accident, stop the bike and reset it to 000 before continuing on your way.

## **17 Odometer Reset**

Hold + while this parameter is active to reset your bike's total distance traveled to 0.

# Maintenance

- Always disconnect the main battery before undertaking any cleaning, maintenance, or repair. For the longest possible service life, disconnect the battery between uses.
- Check the parts of the bicycle for any looseness, stiffness, wear, or damage after each use. Tighten, lubricate, repair, or replace any problematic parts before further use. Only replace components of this bike and its accessories with identical ones.
- The exterior of the bicycle can be cleaned with a soft damp cloth. Do not use harsh abrasives or caustic chemicals. All electronic components have waterproofing adequate for rain, but avoid direct pressurized spray that might allow the interior of the electronic components to become wet, never charge the battery while it or your hands are wet, and immediately replace the battery if it ever begins to swell or leak fluid.
- If the bicycle will not be used for an extended period of time, remove the battery and store everything in a cool dry place away from direct sunlight and inaccessible to children. Avoid storing electronics in plastic bags, which might allow humidity to build up over time. For best results, check the battery every three months. If its power sinks below  $\frac{3}{4}$  (3 of the 4 indicator lights), recharge to at least that full before returning it to storage.

# Troubleshooting

## General Instructions

Problems	Causes	Solutions
Slipping chain	<ul style="list-style-type: none"> <li>Excessively worn/chipped front cog or rear cassette</li> <li>Chain worn/stretched</li> <li>Stiff link in the chain</li> <li>Non-compatible chain</li> </ul>	<ul style="list-style-type: none"> <li>Replace the chain front cog, rear cassette, and chain.</li> <li>Replace the chain.</li> <li>Lubricate or replace the link.</li> <li>Seek advice at a bicycle shop.</li> </ul>
Constant clicking noises when pedaling	<ul style="list-style-type: none"> <li>Stiff chain link</li> <li>Loose pedal axle/bearing</li> <li>Loose bottom bracket axle/bearings</li> <li>Bent bottom bracket or pedal axle</li> <li>Loose crankset</li> </ul>	<ul style="list-style-type: none"> <li>Lubricate the chain/adjust the chain link.</li> <li>Adjust the bearings/axle nut.</li> <li>Adjust the bottom bracket.</li> <li>Replace the bottom bracket axle or pedals.</li> <li>Tighten the crank bolts.</li> </ul>
Grinding noise when pedaling	<ul style="list-style-type: none"> <li>Pedal bearings are too tight.</li> <li>The bottom bracket bearings are too tight.</li> </ul>	<ul style="list-style-type: none"> <li>Adjust the bearings.</li> <li>Adjust the bearings.</li> </ul>
Brakes not working effectively	<ul style="list-style-type: none"> <li>Brake pads worn down</li> <li>Brake pads greasy, wet, or dirty</li> <li>Brake cables are binding/stretched/damaged</li> <li>Brake levers are binding</li> <li>Brakes out of adjustment</li> </ul>	<ul style="list-style-type: none"> <li>Replace the brake pads.</li> <li>Clean the pads.</li> <li>Clean/adjust/replace the cables.</li> <li>Adjust the brake levers.</li> <li>Center the brakes.</li> </ul>
When applying the brakes, they squeal/squeak	<ul style="list-style-type: none"> <li>Brake pads worn down</li> <li>Brake pads toe-in incorrect</li> <li>Brake pads/rim dirty or wet</li> <li>Brake arms loose</li> </ul>	<ul style="list-style-type: none"> <li>Replace the pads.</li> <li>Correct pads toe-in.</li> <li>Clean the pads and rim.</li> <li>Tighten the mounting bolts.</li> </ul>
Knocking or shuddering when applying brakes	<ul style="list-style-type: none"> <li>Bulge in the rim or rim out of true</li> <li>Brake mounting bolts loose</li> <li>Brakes out of adjustment</li> <li>Fork loose in the head tube</li> </ul>	<ul style="list-style-type: none"> <li>True wheel or take to a bicycle shop for repair.</li> <li>Tighten the bolts.</li> <li>Center the brakes and/or adjust the brake pads toe-in.</li> <li>Tighten the headset.</li> </ul>
The power indicator lights not turning on when pressing the power display button on the battery	<ul style="list-style-type: none"> <li>Battery drained.</li> <li>Key not in its <b>ON</b> position</li> </ul>	<ul style="list-style-type: none"> <li>Recharge the battery.</li> <li>Turn the key to <b>ON</b>.</li> </ul>
Unable to remove battery from bicycle	<ul style="list-style-type: none"> <li>Key not in its <b>UNLOCK</b> position</li> </ul>	<ul style="list-style-type: none"> <li>Push in the key, turning it counterclockwise to <b>UNLOCK</b>.</li> </ul>





# Troubleshooting

## General Instructions

Problems	Causes	Solutions
Charging Failure	<ul style="list-style-type: none"><li>• Charger not correctly connected</li><li>• Battery in an over-low-power state</li><li>• Charger/ power cord/battery broken</li></ul>	<ul style="list-style-type: none"><li>• Ensure the charger is correctly connected to a working power source.</li><li>• Revive the battery in an over-low-power state.<ol style="list-style-type: none"><li>1. Reinstall the battery onto your bicycle.</li><li>2. Raise the motorized wheel.</li><li>3. Run the motor using the throttle handle for a while.</li><li>4. Stop the motor, disconnect the battery, and restart charging.</li></ol></li><li>• Replace the charger, its power cord, or the battery with a new identical one.</li></ul>
Display Panel Failure	<ul style="list-style-type: none"><li>• Battery not seated in place</li><li>• Key not in its <b>ON</b> position</li><li>• Mechanical cause</li></ul>	<ul style="list-style-type: none"><li>• Seat the battery in place.</li><li>• Turn the key to its <b>ON</b> position.</li><li>• Have trained technicians inspect, retighten, repair, or replace the related wiring and/or problematic parts.</li></ul>

# Troubleshooting

## Error Codes

Code	Icon	Problem	Usual Solutions
E02		Brake Lever Failure	This code and icon are displayed every time the brake levers disconnect the motorized wheel from its power. This is normal and indicates everything is working correctly.
			If either or both are displayed when the brake levers are not engaged, something has malfunctioned. Check the wiring and condition of the brake levers, lines, and motorized wheel. Replace any problematic parts with new identical ones.
E06		Undervoltage Knockout	Refill the battery.
			Replace the battery with a new identical one.
E07		Motor Failure	Retighten the appropriate wire connection(s).
			Replace the motorized wheel with a new identical one.
E08		Throttle Failure	This icon is displayed when throttle control is disabled. (See Parameter 10 in the Adjustment section above.) This is normal and indicates everything else is working correctly.
			If this icon is displayed when throttle control is not disabled, something has malfunctioned. Check the wiring and condition of the throttle and motor. Repair or replace any problematic parts.
E09		Control Hardware Failure	Retighten the appropriate wire connection(s).
			Check the condition of the control hardware. Repair or replace any problematic parts.
E10	—	Communication Failure	Retighten the appropriate wire connection(s).
			Check the condition of the display panel, throttle, and motorized wheel. Repair or replace any problematic parts.
E16	—	Short Circuit	Have a trained technician check all electronic components and repair or replace any problematic parts.



# Disposal

Electrical products should not be disposed of with household products. In the EU and UK, according to the European Directive 2012/19/EU for the disposal of electrical and electronic equipment and its implementation in national laws, used electrical products must be collected separately and disposed of at the collection points provided for this purpose. Locations in Australia, Canada, and the United States may have similar regulations. Contact your local authorities or dealer for disposal and recycling advice.

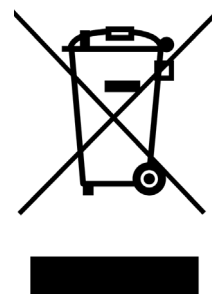

## Contact Us

Thank you for choosing our products! If you have any questions or comments, contact us at [support@viribusbikes.com](mailto:support@viribusbikes.com) and we'll resolve your issue ASAP!

For a .pdf copy of the latest version of these instructions, use the appropriate app on your smartphone to scan the QR code to the right.

