

Adult Tricycle User Manual



Read Carefully Before Use
Keep for Future Reference

Disaclaimer

Read this disclaimer carefully **BEFORE** use.

1. As-is

This product(s) is sold 'as is' and without any express or implied warranties, including but not limited to the implied warranties of merchantability and fitness for a particular purpose.

2. Product Modifications

Any modifications or alterations to VIRIBUS products void any warranties and may result in damage or injury. VIRIBUS shall not be liable for any damages resulting from such modifications or alterations.

3. Compliance with Laws

Customers shall be liable for ensuring that the use of VIRIBUS products complies with all applicable laws and regulations in their respective jurisdictions. VIRIBUS assumes no responsibility for any violations of laws or regulations resulting from the use of its products.

4. Correct Use

Always use the product(s) only as directed in the accompanying manual. Failure to follow instructions may result in injury or damage.

Always ensure the operation, installment, maintenance, and repair of the product(s) is carried out by a competent person.

Always make maintenance regularly throughout the product lifecycle, you have the liability to keep the product operating as intended.

Always wear appropriate protective gear.

5. Third-Party Products

VIRIBUS shall not be liable for any damages or losses resulting from the use of third-party products in conjunction with our products. Customers should refer to the third-party's guidelines or/and warranties (if any) for any third-party products used.

6. Limitation of Liability

VIRIBUS shall not be liable for any direct, indirect, punitive, incidental, special, or consequential damages to property or life, whatsoever arising out of or connected with the use or misuse of our product(s). In no event shall VIRIBUS's liability exceed the value of the product(s) sold.

This disclaimer states the entire obligation of VIRIBUS with respect to the products. If any part of this disclaimer is determined to be void, invalid, unenforceable, or illegal, including, but not limited to the warranty disclaimers, liability disclaimers, and liability limitations set forth above, then the invalid or unenforceable provision will be deemed superseded by a valid, enforceable provision that most closely matches the intent of the original provision and the remainder of the agreement shall remain in full force and effect.

CONTENTS

Safety Information	1
Package List	2
Parts Diagram	2
Assembly	4
Rear Derailleur	4
Rear Wheels	5
Main and Rear Frames	6
Chain.....	7
Front Wheel.....	8
Front Fender	9
Chain Guard.....	10
Handlebars.....	11
Derailleur Cable	12
Front Brake	14
Rear Brake	15
Rear Fenders	16
Saddle	17
Pedals	18
Rear Basket	18
Bell and Front Reflector	20
Wheel Caps.....	20
Folding	21
Speed Gearing Adjustment	23
Maintenance	23

Safety Information

Warning!

Traffic Rules

- **ALWAYS** obey all applicable local and national laws and regulations while riding.
- It is advisable to equip your tricycle with a warning device such as a horn, bell, or light in case you are riding at times of poor visibility. This is even required in some jurisdictions.
- **ALWAYS** be alert. People or animals may dart in front of you. Also be careful of passing parked cars, whose doors might open suddenly.
- Be careful at road and rail crossings. Slow down and check both ways for oncoming traffic.

Weather and Clothing

- In wet weather, be careful to avoid sharp turns and allow more distance for braking. Caliper brakes may become less efficient when wet.
- We **DO NOT** recommend riding your tricycle at night. If you have an emergency that makes it necessary to ride at night, be sure to have proper lights and reflectors. **DO NOT** ride at night without a front light, rear lights, or front and rear reflectors.
- **ALWAYS** wear a helmet and other required protective gear that meet safety standards when riding.
- **ALWAYS** wear shoes when riding your tricycle and avoid loose-fitting clothes.

Safety Checks

- Make sure the main frame is **FULLY** unfolded and **FULLY** locked by its latch before riding.
- Check whether the brakes are positioned properly before riding.
- Regularly check the reflectors to make sure that they are clean, straight, unbroken, and securely mounted. Riding without reflectors is extremely dangerous.
- Regularly check whether all fasteners and components are securely tightened.
- If any part does not operate properly, discontinue use until its replacement.
- Replace worn or broken parts immediately, especially bent or broken spokes and bent or damaged wheel rims.

Sensible Use

- Be mindful of your speed. Ensure you have sufficient room to brake in an emergency.
- Allow more distance for braking when riding through leaves, loose gravel, or other debris as these can also affect the stopping power of your brakes.
- **DO NOT** carry packages or objects on your tricycle in a way that obstructs your view of the road.
- When inflating the tires, **DO NOT** exceed 50 psi (3.5 bar or 350 kPa).

Item	Name	Qty.
1	Chain Guard	1
2	Chain	1
3	Handlebars with Twist Grip Shifter	1
4	Rear Basket Mount	1
5	Saddle	1
6	Left Rear Fender with Stay	1
7	Right Rear Fender with Stay	1
8	Front Fender with Stay	1
9	Rear Derailleur	1
10	Bell	1
11	Front Wheel Caps	2
12	Casters	4
13	Pedals	2
14	Rear Frame	1
15	Rear Basket	1
16	Main Frame with Front Brake Caliper	1
17	Basket Handle	1
18	Mounting Bars	2
19	Phillips Screwdriver	1
20	Front Reflector	1
21	Spring	1
22	Rear Wheel Caps	2
23	Multifunctional Wrench	1
24	6 mm Hex Wrench	1
25	5 mm Hex Wrench	1
26	4 mm Hex Wrench	1
27	Front Wheel	1
28	Right Rear Wheel with D-Shaped Slot	1
29	Left Rear Wheel with O-Shaped Slot	1

Not Included but Helpful:

- 17 mm Wrench
- 22 mm Wrench

When you first get your new tricycle, carefully unpack all of the above-mentioned components and accessories. Check that nothing is missing or has been damaged in transit. Keep children away from the packaging or provide constant supervision. Storing your original packaging through the warranty period will speed returns if any are needed.

For your convenience, all bolts, nuts, and washers are preinstalled where they will be needed. During assembly, simply remove the fasteners as needed and keep them nearby. Reinstall them to connect each part as you go and tighten them securely for safe and satisfactory experience.

Assembly

To see these instructions in video form, go to our YouTube channel **Viribus Workshop** and search for “**ABF-R**”.

Warning

- Wear hand and eye protection during assembly to prevent accidents.
- **DO NOT** allow children or pets to play with **ANY** packaging or tricycle parts without adult supervision.

Note

- Ensure that **ALL** packaging materials have been removed before assembling your new tricycle.
- For each nut with flat and beveled sides, place the flat side against the tricycle surface.

1. Installing the Rear Derailleur

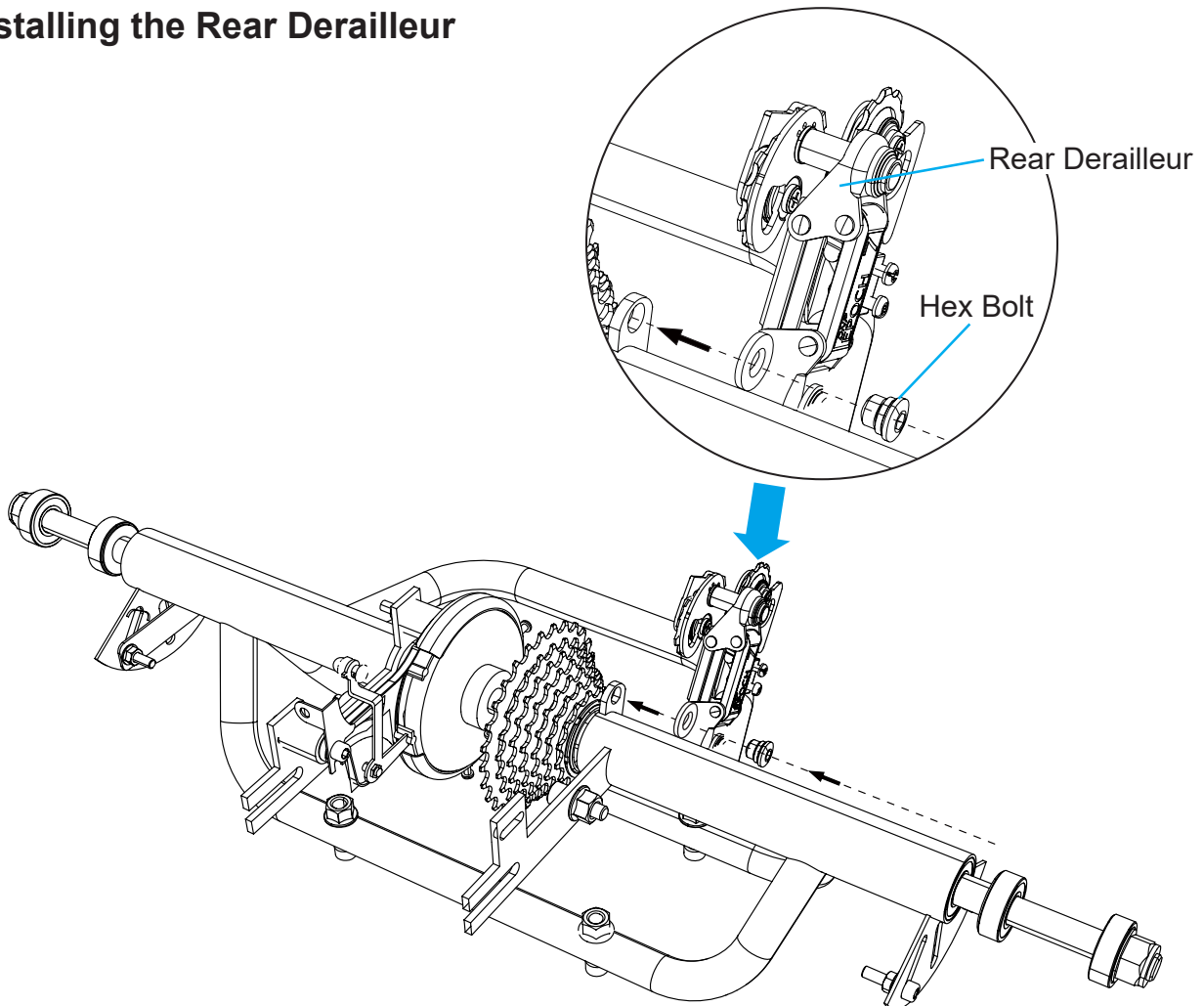

1. Secure the rear derailleur (9) to its slot on the rear frame (14) as shown.
2. Tighten the hex bolt with the 6 mm hex wrench (24).

Note: Make sure the derailleur is **TIGHTLY** secured. Otherwise, the chain installation will be impacted.

2. Installing the Rear Wheels

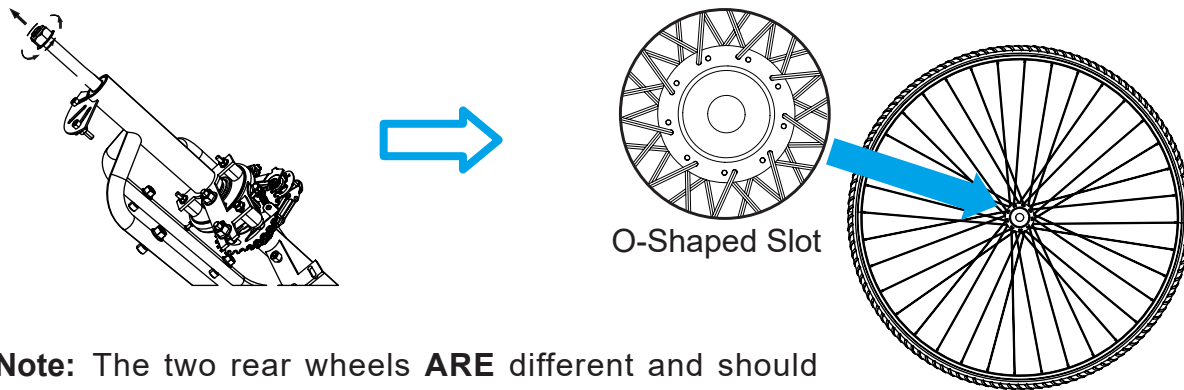

Note: The two rear wheels **ARE** different and should **NOT** be mixed up. The wheel with the O-shaped slot goes with the O-shaped hub on the left side of the rear axle while the wheel with the D-shaped slot goes with the D-shaped hub on the right side.

1. Remove the nut and washer from the O-shaped hub on the left side of the rear frame by hand. Place them nearby.
2. Connect the left wheel (29) with the O-shaped slot to the O-shaped hub.
3. Replace the washer and nut, tightening the nut with a 22 mm wrench (not included) to secure the left wheel in place.
4. Remove the nut and washer from the D-shaped hub on the right side. Place them nearby.
5. Connect the right wheel (28) with the D-shaped slot to the D-shaped hub.
6. Replace the washer and nut, securing the right wheel in the same fashion.

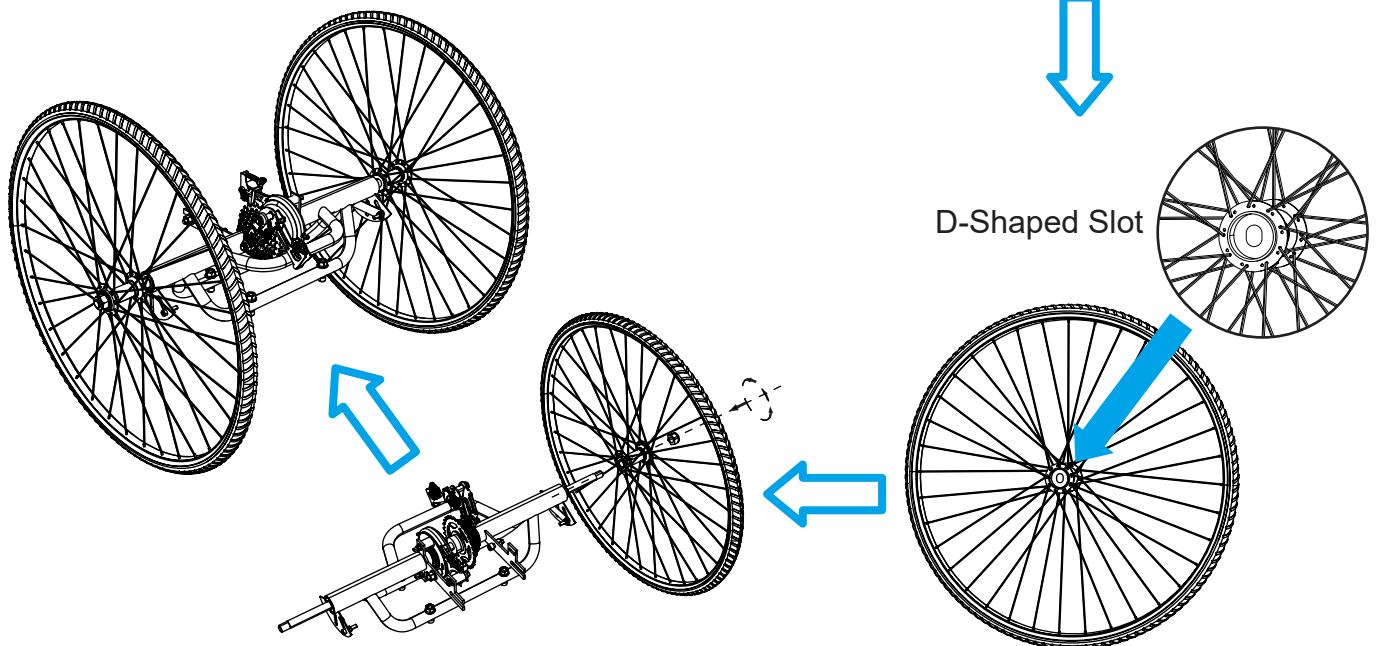
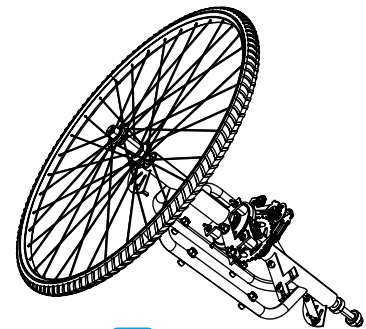
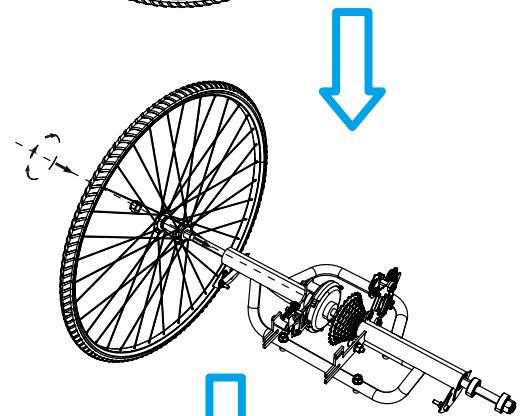

3. Connecting the Main and Rear Frames

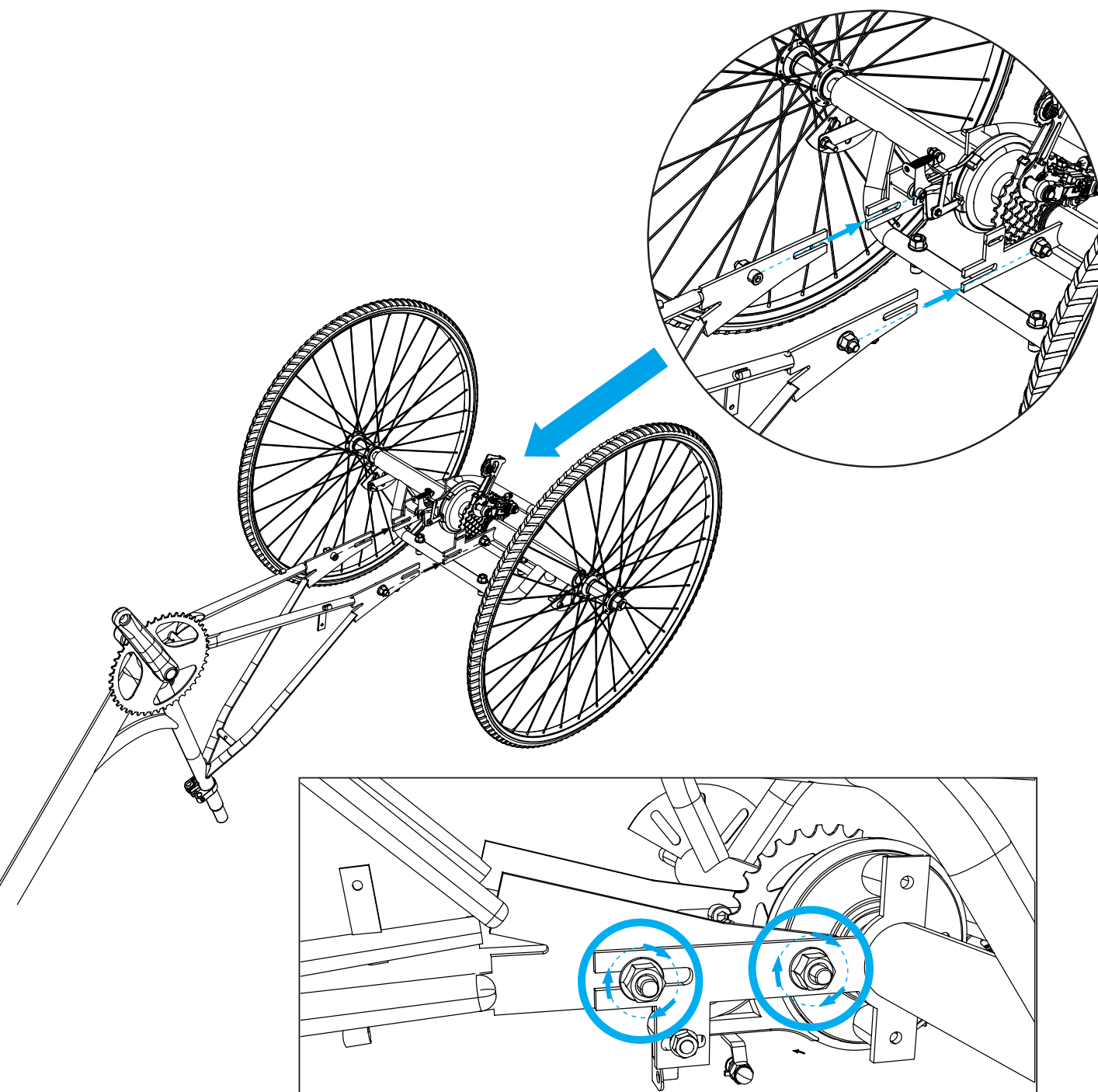

1. Loosen the nuts on the protective bar preinstalled on the tail of the main frame (16) by hand and then remove the bar from the frame.
2. Loosen the nuts beside the long slots on both sides of the main and rear frames.
3. Turn the main frame upside down, aligning its slots and bolts with the bolts and slots on the rear frame.
4. Slide the main frame onto the rear frame as shown. For best results, start with either side and repeat for the other side.
5. Partially tighten the nuts with a 17 mm wrench (not included). (Fully tighten them later after chain installation.)

4. Installing the Chain

1. Find the two non-preinstalled chain links in the chain bag and connect them to each other by pushing their pins into their slots. Place them nearby.
2. Position one end of the chain (2) around the front cog.
3. Pass the other end of the chain through the guide pulley of the rear derailleur, arranging the chain in an S shape.
4. Run the chain around the largest rear cog.
5. Pull the ends of the chain together to see if the length is suitable.
6. If the chain is too long, use a chain tool (not included) to push out the pins connecting the links you want to remove until the chain is the appropriate length.
7. Join both ends of the chain using the above-mentioned chain links in the same fashion.
8. Pull the chain taut with both hands, testing that it cannot be torn apart.
9. Tighten all the nuts connecting the main and rear frames completely.

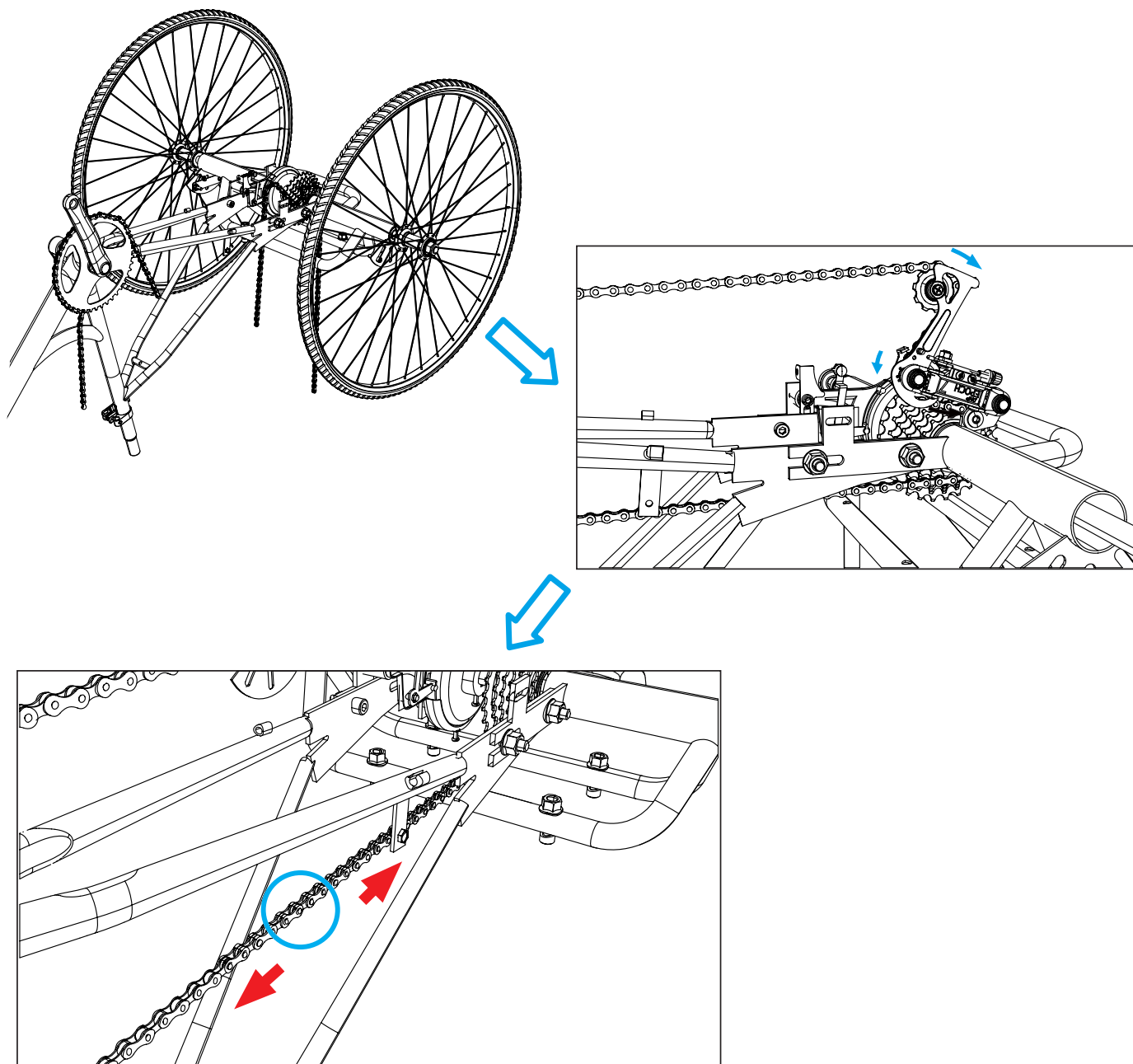

5. Installing the Front Wheel

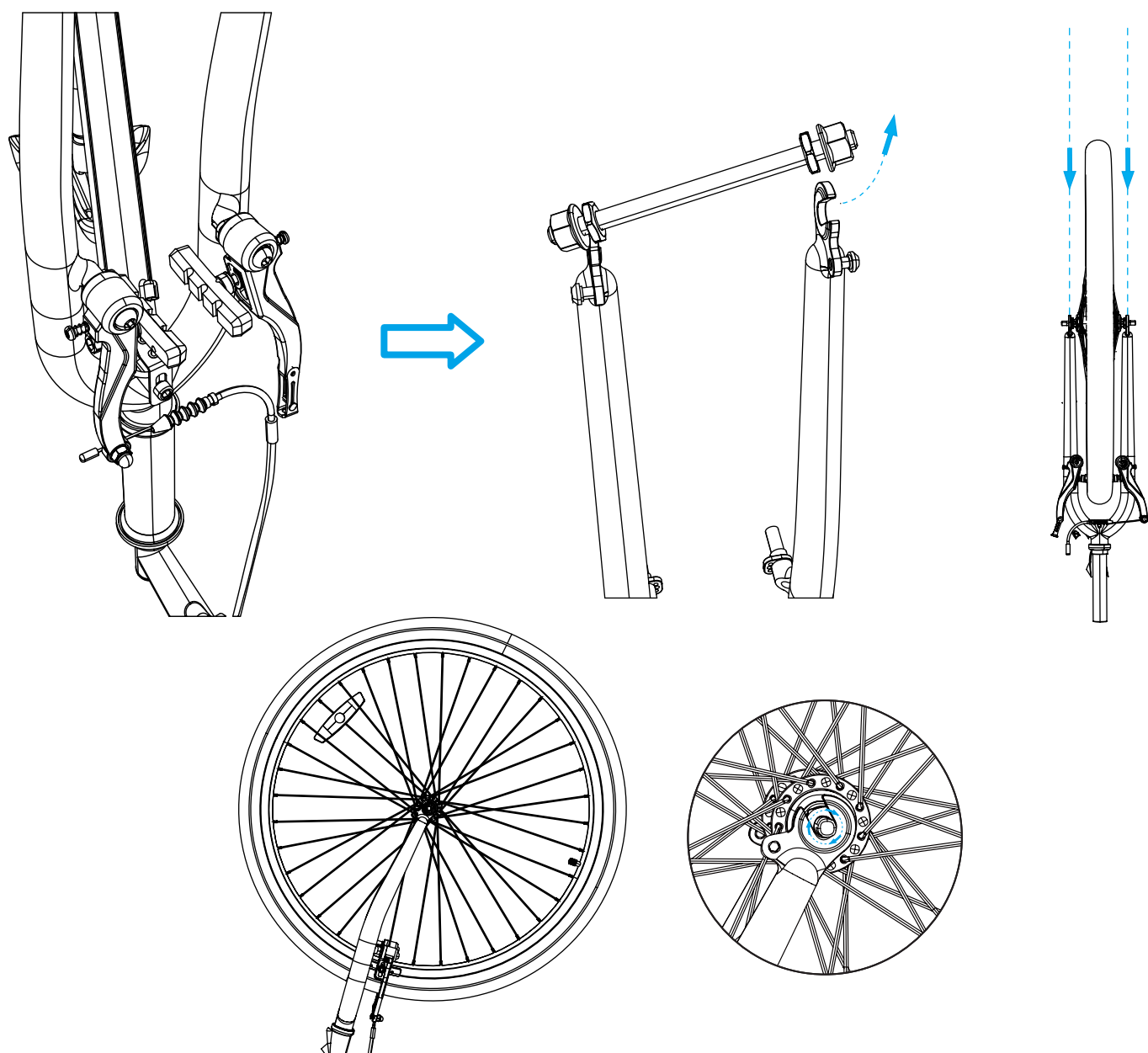

1. Press and disconnect the V-shaped front brake on the main frame's front fork.
2. Loosen the nuts on the protective bar preinstalled on the front fork by hand and then remove the bar from the fork.
3. Loosen the nuts and retaining clips on the front wheel (27) by hand. Fit the wheel into the front fork, allowing the fork to catch its axle snugly between the clips and its hub.
4. Mount the retaining clips into place using their tabs as shown.
5. Retighten the nut on each side with the multifunctional wrench (23) to lock the front wheel in place.

6. Installing the Front Fender

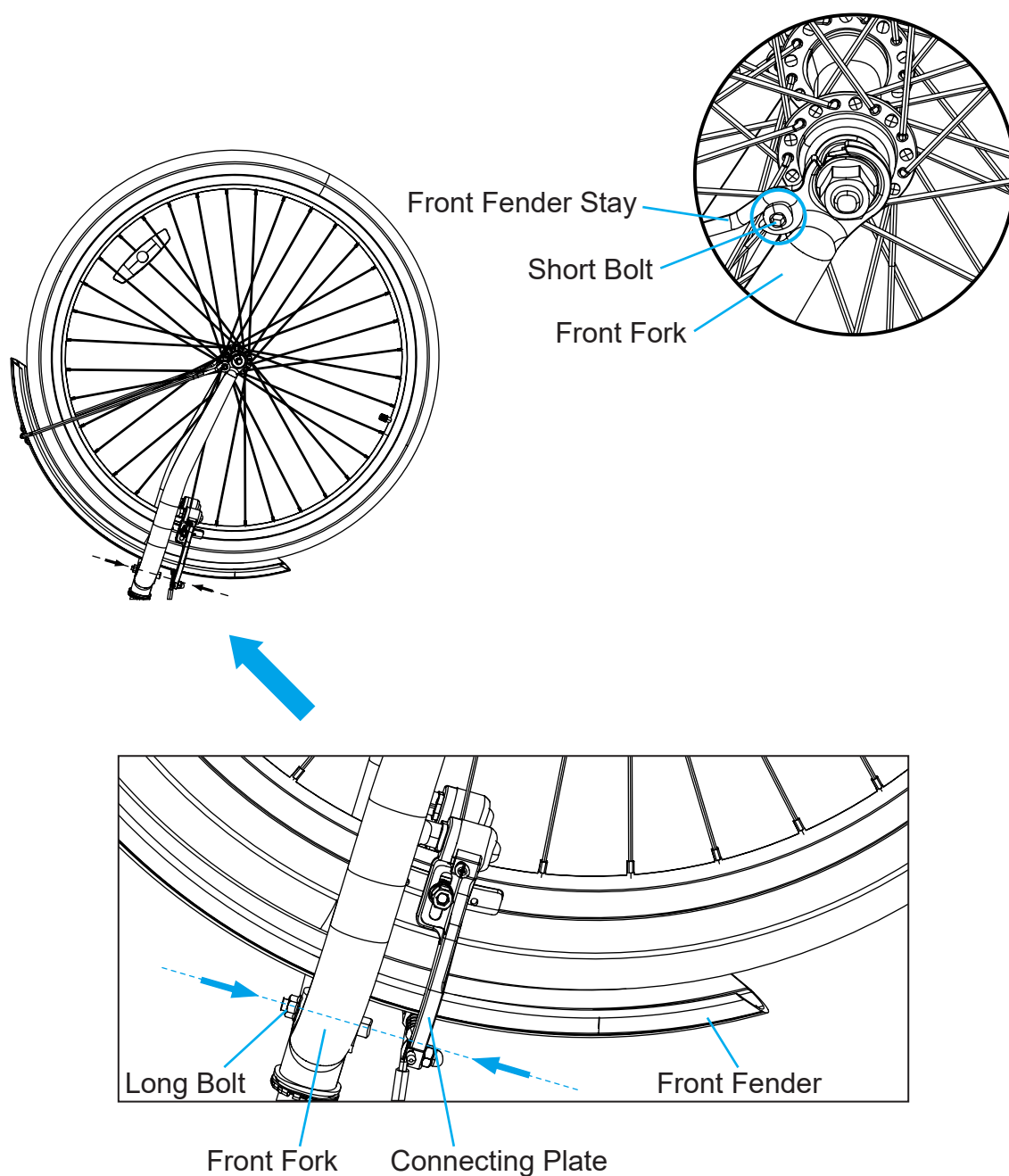

1. Remove the nut from long bolt at the top of the front fork by hand. Place it nearby.
2. Fit the front fender (8) over the front wheel, allowing the long bolt to pass through its top slot as shown.
3. Replace the nut onto the long bolt, partially tightening them with the multifunctional wrench and Phillips screwdriver.
4. Remove the short Phillips bolts from the front fork's tips. Place them nearby.
5. Align the slots on the front fender stay with those on the fork's tips.
6. Replace and tighten the short bolts to secure the fender stay to the tricycle frame.
7. Continue to tighten the long bolt and its nut until the front fender is tightly fastened.

7. Installing the Chain Guard

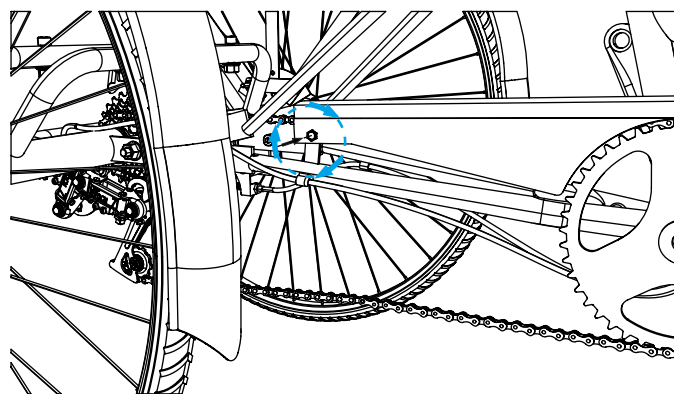
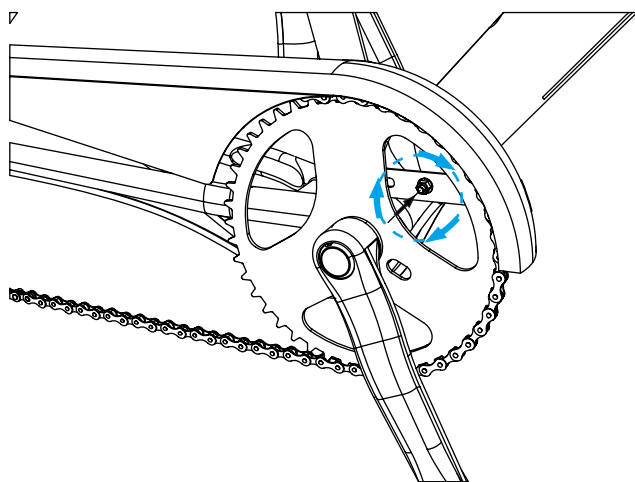
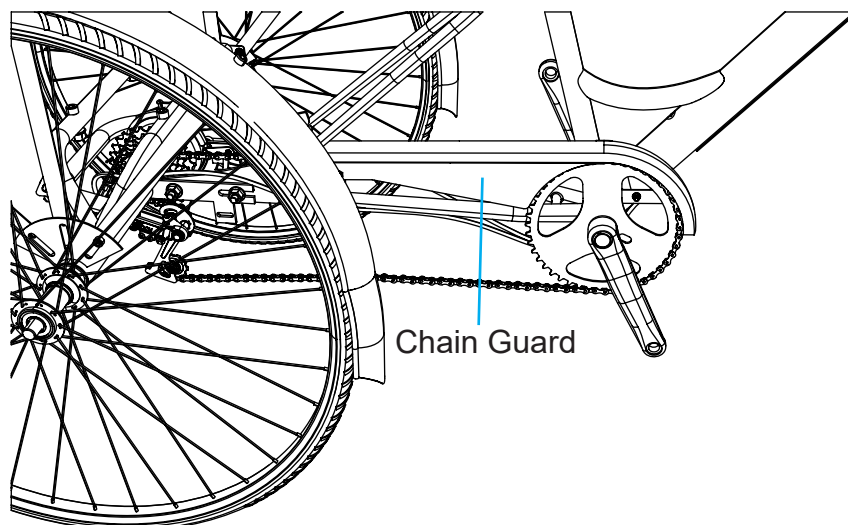

1. Turn the tricycle frame right side up.
2. Remove the two bolts from the guard supports near the front and rear cogs with the Phillips screwdriver (19). Place them nearby.
3. Position the chain guard (1) onto its supports and over the chain as shown.
4. Replace the Phillips bolts, tightening them to secure the guard in place.
5. Rotate the chain to see if it rubs against the guard. If it does, readjust the guard so that the chain moves freely.

8. Installing the Handlebars

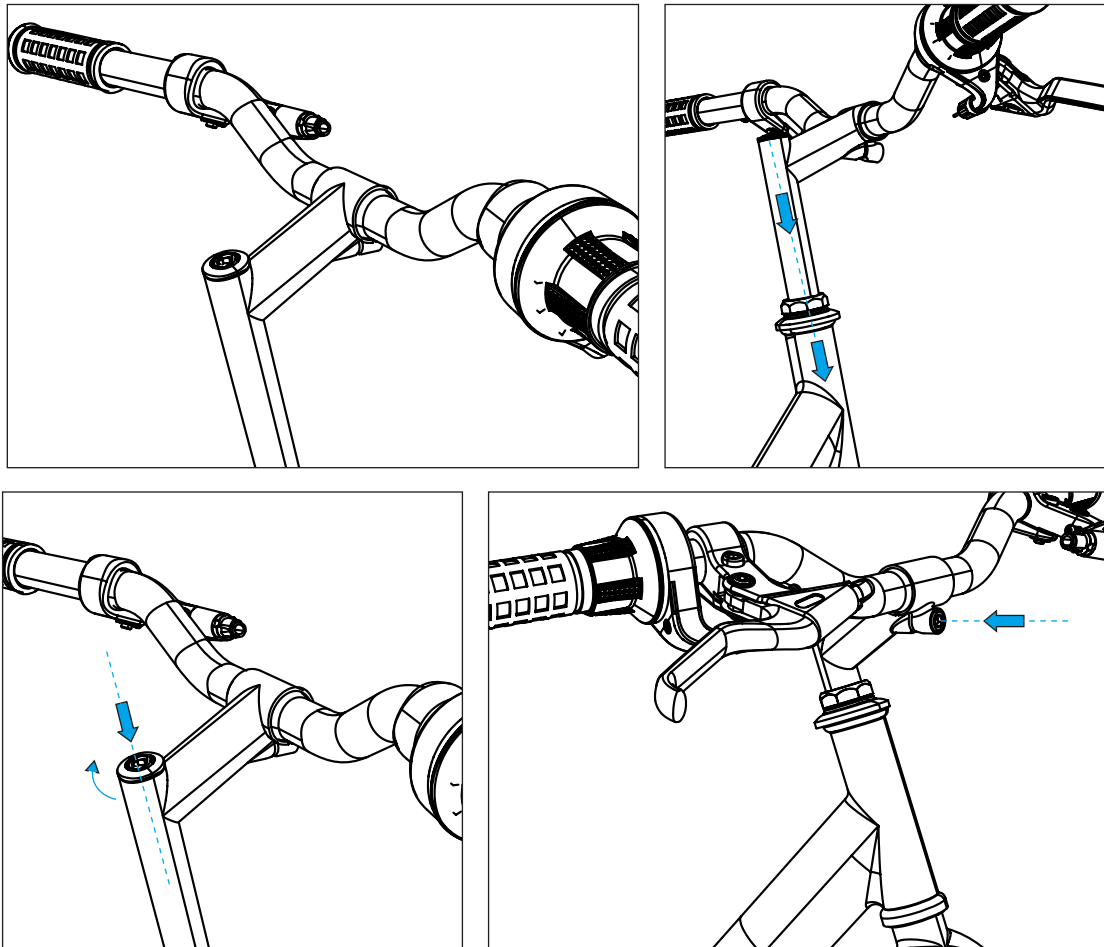

 Handle the exposed steerer tube carefully to avoid injury.

1. Remove the protective cover underneath the steerer tube of the handlebars (3).
2. Loosen the bolt on the top of the steerer tube with the 6 mm hex wrench (24).
3. Slide the steerer tube into the head tube of the main frame until your desired height is reached.
4. Adjust the angle of the handlebars until they become perpendicular to the front wheel.
5. Retighten the top bolt to secure the handlebars to the head tube.
6. Loosen the bolt on the front of the handlebars' headset in the same fashion.
7. Lift the grips to an appropriate position, retightening the front bolt to lock the headset completely.

9. Installing the Derailleur Cable

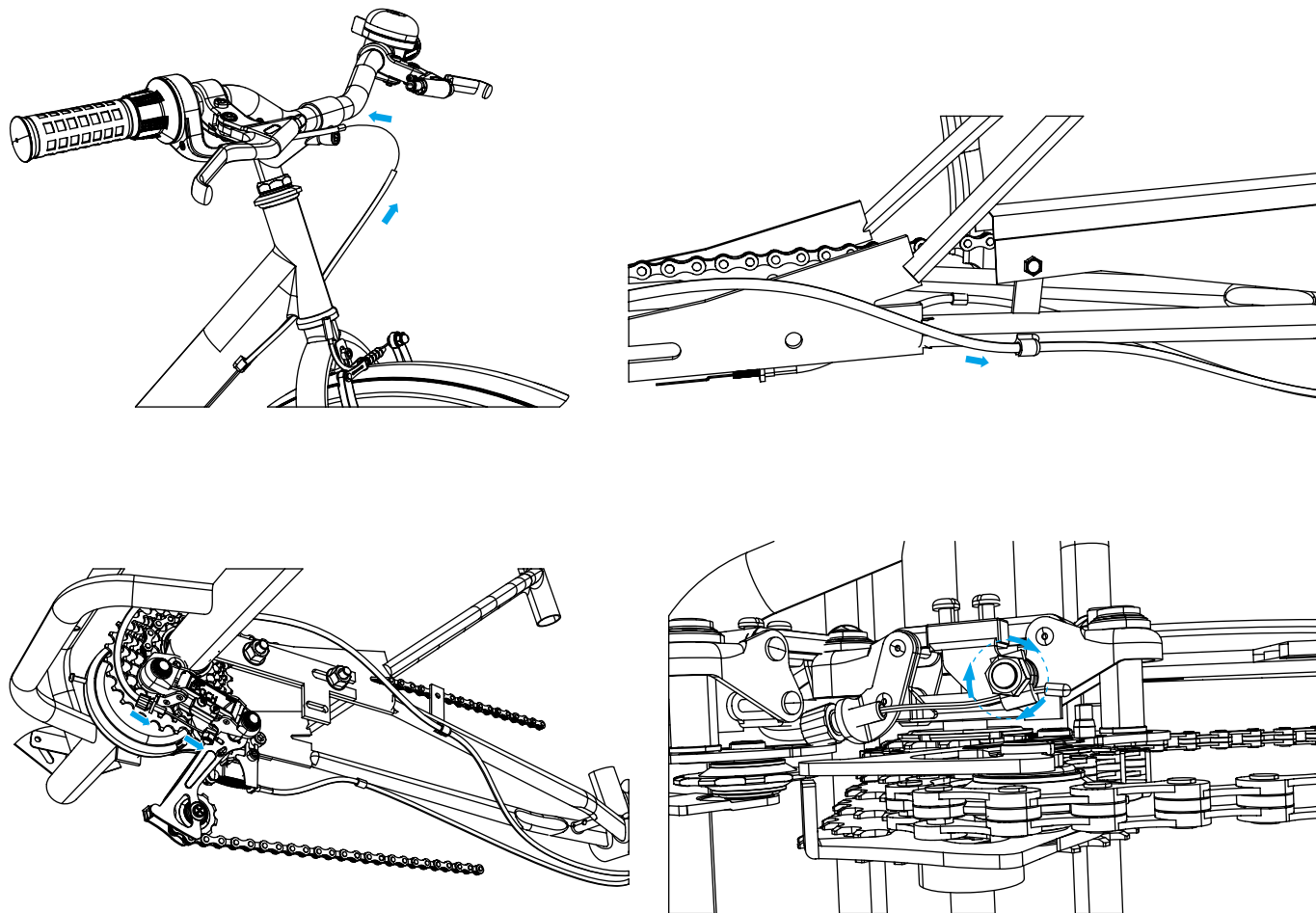

1. Thread the derailleur cable from the right handlebar into the outer casing in the slots along the down tube and chain stay of the main frame.
2. Thread the exposed part of this cable into the other casing and then feed this casing into the slot on the chain stay.
3. Pass the cable through the barrel adjuster on the rear derailleur.
4. Loosen the nut on the derailleur by hand and position the cable behind its washer.
5. Retighten the nut with the multifunctional wrench to secure the cable in place.
6. Knot the remaining exposed cable appropriately if needed.

Testing the Derailleur



Note: ALWAYS test the rear derailleur before first use.

1. Confirm that the derailleur is secure to the rear frame.
2. Turn the twist grip shifter on the right handlebar to **1** to put the tricycle in its lowest gear.
3. Upshift through the gears towards **7** while turning the trike's crank. The chain should smoothly move from the largest cog to the smallest cog.

If necessary, use the barrel adjuster to fine tune each gear. Loosen the adjuster to release cable tension and move the chain away from the wheel. Tighten it to enhance cable tension and direct the chain towards the wheel.



If the chain cannot be exactly positioned on the smallest cog at the highest gear, adjust the high-limit screw (**H**) using the Phillips screwdriver until the guide pulley and the smallest cog are lined up.

4. Downshift through the gears towards **1** while turning the crank, checking that each gear operates smoothly. Fine tune the gears using the barrel adjuster as described above if necessary.

If the chain fails to return to the largest cog at the lowest gear, adjust the low-limit screw (**L**) with the Phillips screwdriver until the guide pulley and the largest cog are aligned vertically.

5. Repeat Steps 3 & 4 several times until you are certain the derailleur is properly adjusted.

10. Installing the Front Brake

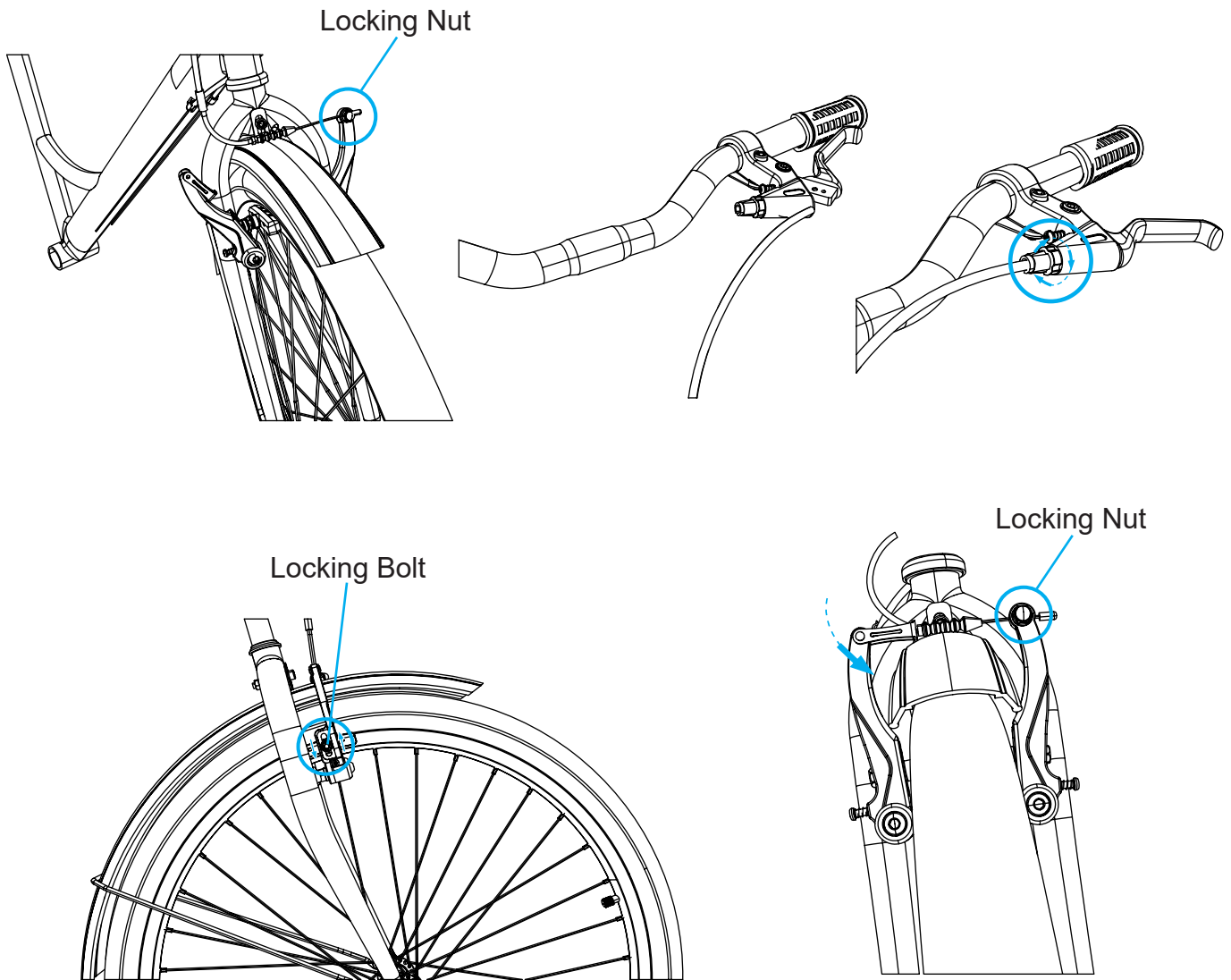

1. Loosen the locking nut on the V-shaped front brake by hand and release the cable as needed.
2. Pass the round metal head of the front brake cable through the appropriate brake handle: Left in the United States and right in the United Kingdom.
3. Feed the cable's outer casing into the brake handle, retightening its locking nut by hand.
4. Position the brake pads over the front wheel's rim, tightening their locking bolts with the 5 mm hex wrench (25). Do not allow them to touch the tire.
5. Making sure the cable is taut, press the front brake and retighten its locking nut with the multifunctional wrench.
6. Test the front brake by pressing the corresponding brake handle.

If necessary, loosen the barrel adjuster to reduce the cable tension or retighten it to increase the tension until you feel comfortable with the brake handle while the front brake effectively stops the front wheel.

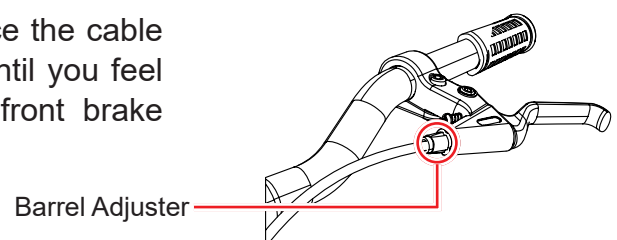

11. Installing the Rear Brake

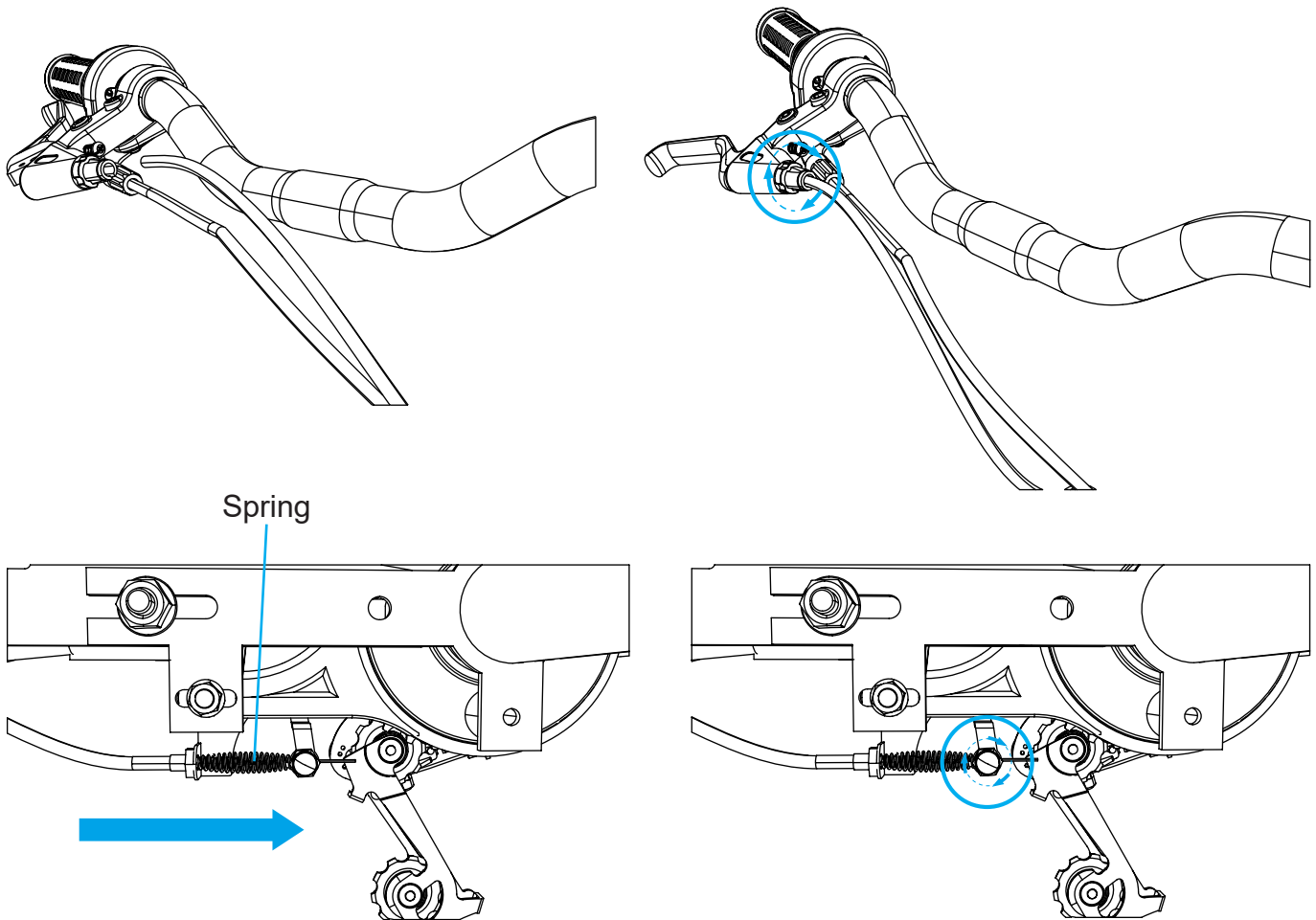

1. Pass the round metal head of the rear brake cable through the appropriate brake handle: Right in the United States and left in the United Kingdom.
2. Feed the cable's outer casing into the brake handle, tightening its locking nut by hand.
3. Feed the rear brake cable through the spring (21) and past the cable clamp.
4. Tighten the locking nut of the cable clamp with the multifunctional wrench.
5. Test the rear brake by pressing the corresponding brake handle and pushing the tricycle forward.

If necessary, adjust the barrel adjusters to fine-tune the cable tension, ensuring that pressing the brake handle easily and effectively stops the rear wheel.

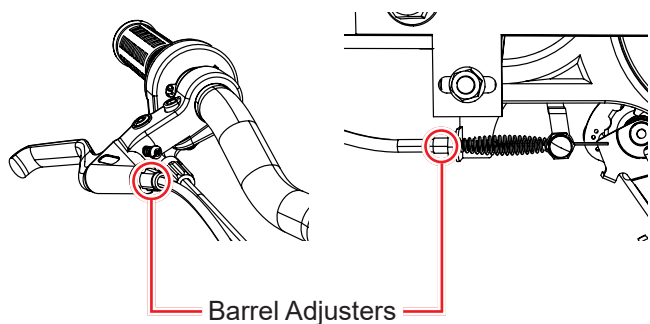

12. Installing the Rear Fenders

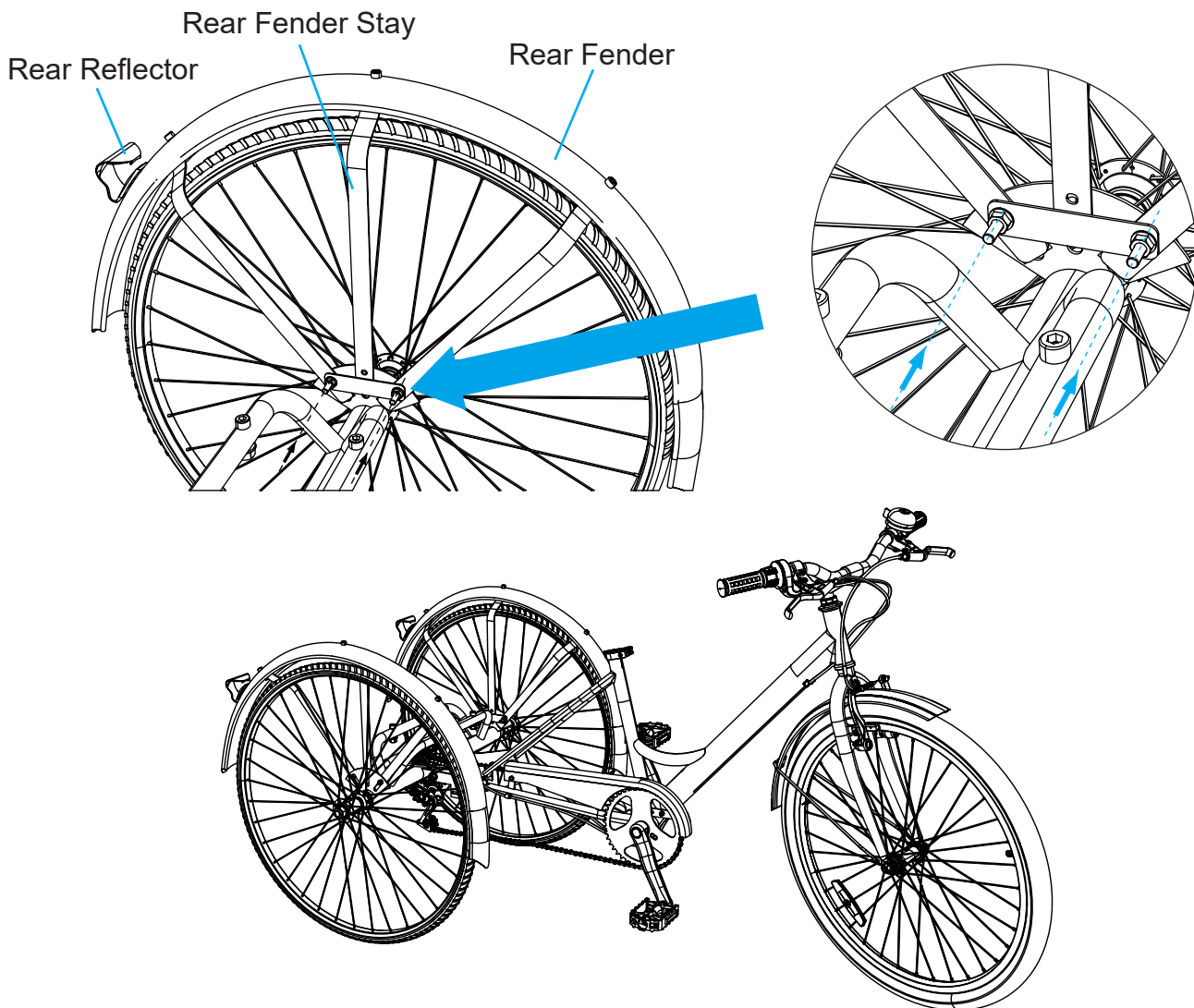

1. Differentiate the two rear fenders, which should **NOT** be mixed up.
 - The left rear fender (6) stay is arched towards the rear reflector's right side.
 - The right rear fender (7) stay is arched towards the rear reflector's left side.
2. Remove the 2 sets of nuts and bolts from the fender support on the left side of the rear frame. Place them nearby.
3. Place the left rear fender (6) over the left rear wheel, aligning its stay with the fender support and taking care not to allow the stay to touch the tire or wheel rim.
4. Replace the bolts and nuts, tightening them with the Phillips screwdriver and multifunctional wrench.
5. Install the right rear fender (7) over the right rear wheel following the same steps.

Rear Reflectors

Rear Reflector

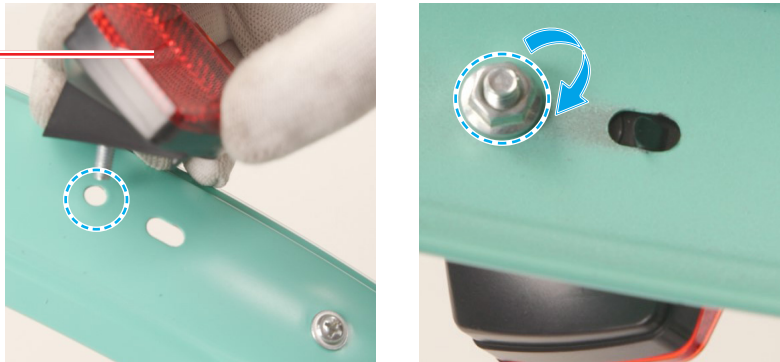

If the rear reflectors are not preinstalled on the rear fenders, take the following steps before installing the rear fenders:

1. Remove the nuts from the bolts on the rear reflectors.
2. Attach the reflectors to the rear fenders using their bolts.
3. Secure these reflectors by replacing and tightening their nuts.

13. Installing the Saddle

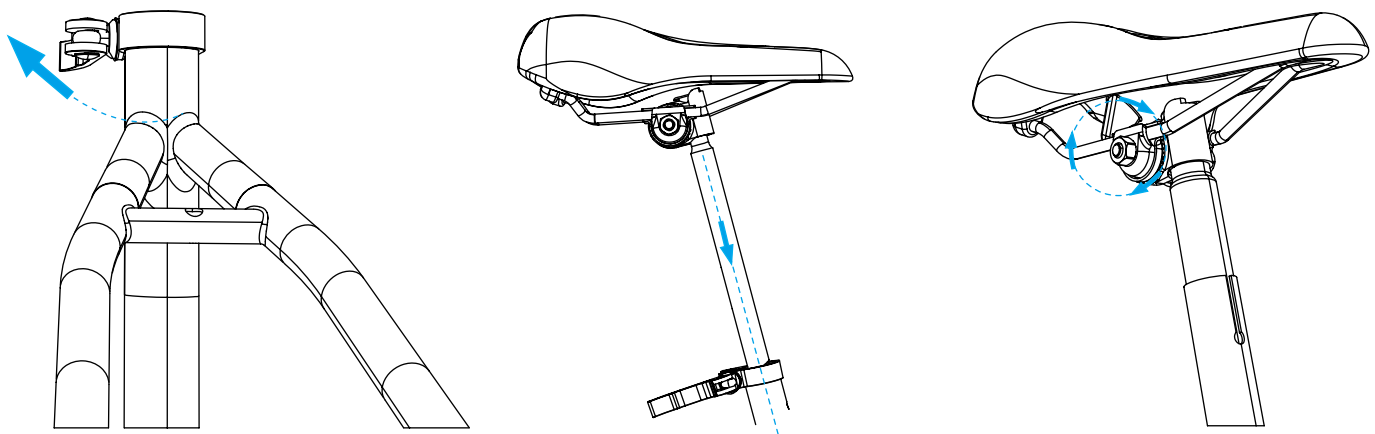

1. Loosen the bolt and pull the lever on the saddle clamp at the top of the seat tube as shown.
2. Insert the post of the saddle (5) into the seat tube until your preferred height is reached.
3. Retighten the bolt and push the lever back to secure the saddle firmly.
4. To adjust the saddle forward or backward, loosen the two nuts underneath the saddle using the multifunctional wrench, slide the saddle on its support frame until your desired position is reached, and retighten the nuts. Confirm they hold tight and the saddle does not show any wobble.

14. Installing the Pedals

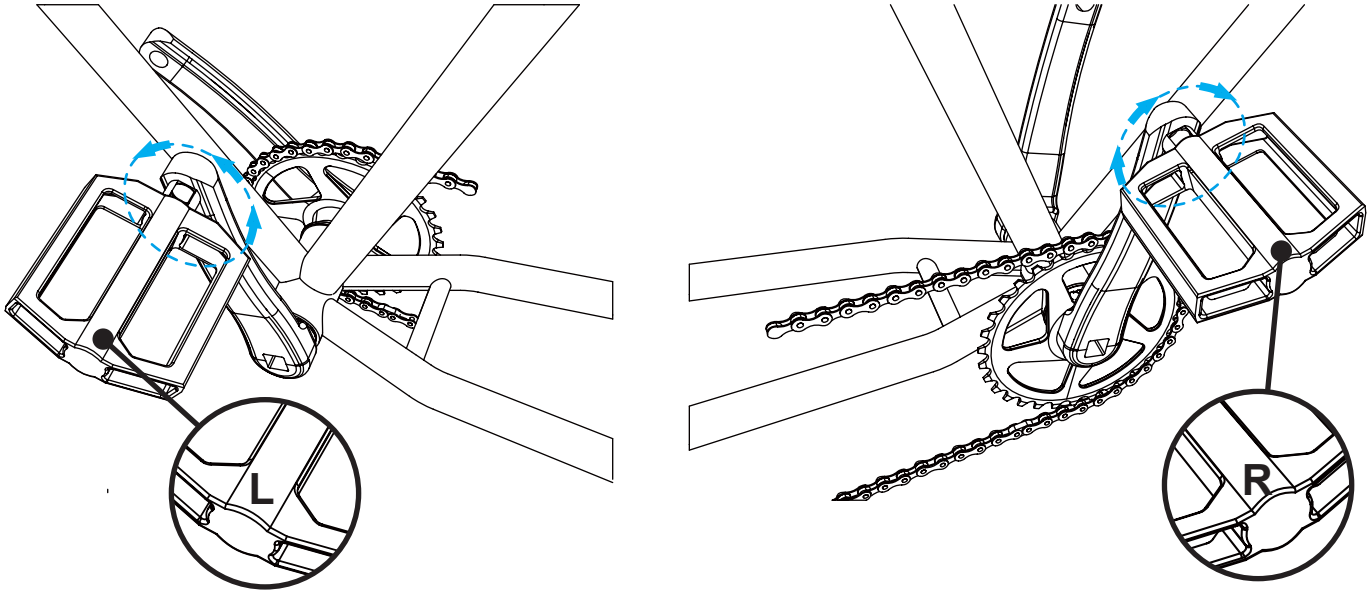

Note: The two pedals (13) **ARE** different and should **NOT** be mixed up. The right pedal is marked with an **R** and the left with an **L**.

1. Attach the pedals to the crank arms on the appropriate side, screwing them into place.
2. Tighten their locking nuts with the multifunctional wrench.
3. Test that the chain turns smoothly while using the pedals. Adjust as needed.

15. Installing the Rear Basket



1. Remove the 4 sets of nuts and bolts from the top of the rear frame by hand. Place them nearby.
2. Fit the basket mount (4) onto the rear frame, aligning their slots and setting the attached locking clamp to face backwards.
3. Replace the bolts and nuts, tightening the nuts with the multifunctional wrench until the mount is firmly secured.

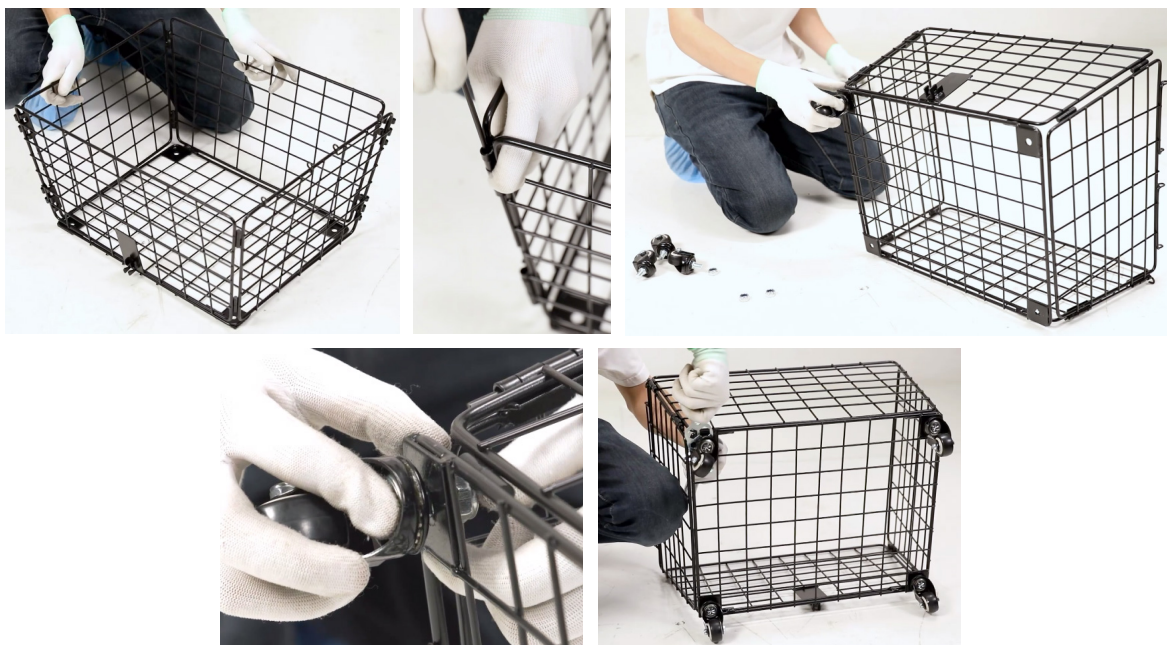

4. Unfold the five sides of the rear basket (15).
5. Connect all sides of the basket by inserting the mounting bars (18) into their slots as shown.
6. Remove the nuts from the bolts on the casters (12). Place them nearby.
7. Attach the casters to the bottom corners of the rear basket using their bolts.
8. Replace the nuts onto the bolts, tightening them with the multifunctional wrench to secure the casters in place.



9. Remove the nuts and bolts from the basket handle (17) by hand. Place them nearby.
10. Connect the handle to the rear basket, aligning their slots as shown.
11. Replace the bolts and nuts, tightening them with the Phillips screwdriver and multifunctional wrench to fasten the handle into place.
12. Position the basket onto its mount and secure it using the locking clamp mentioned in Step 2.

16. Installing the Bell and Front Reflector



1. Remove the bolt from the clamp of the bell (10) by hand. Place it nearby.
2. Position the bell onto a convenient location on the handlebars using its clamp.
3. Replace the bolt onto the clamp, tightening it with the Phillips screwdriver until the bell is securely fastened.
4. Install the front reflector (20) in the same fashion.

17. Installing the Wheel Caps

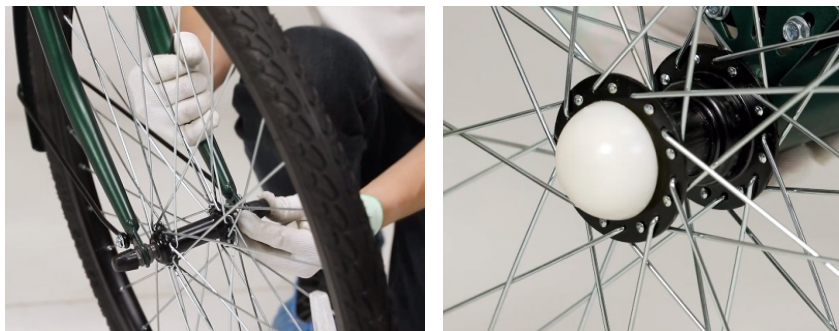

1. Attach the front wheel caps (11) to both sides of the front wheel hub.
2. Press the caps until they are firmly fixed.
3. Install the rear wheel caps (22) onto the rear wheel hubs in the same fashion.

Folding

To fold your tricycle for easier storage or transport,

1. Open the handle and pull its bolt out of its holding bracket.



If you find that this action is excessively difficult, apply lubrication to all the bolts in the tricycle's hinge. Once the handle bolt is out of its holding bracket, rotate the entire handle to change its distance from the inner hinge.



Be mindful that making the handle too loose will reduce its ability to hold the hinge closed.

2. Raise the locking pin.

Do this by supporting the base of the handle with the top of your palm while at the same time positioning your thumb over the frame. Pull straight up with your palm while pushing down with your thumb. You should hear the pin disengage, leaving the front of the tricycle free to adjust.

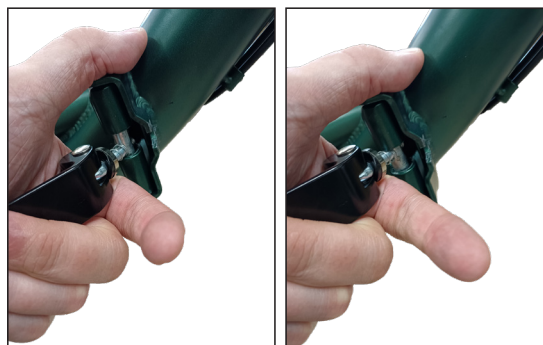

Be sure to apply force to the **BASE** of the handle. The rest of the handle is only for moving its bolt in and out of the holding bracket and for adjustment. Attempting to use it to disengage the locking pin will involve excessive difficulty and force and may damage components.

- Pivot the front of the tricycle to the desired position. The hinge cannot lock into place while it is open, so use a bike lock if this necessary in your location.



 Be mindful of the brake cables as you pivot the front of the tricycle. Do not allow the hinge to abrade or clamp them.

To move the tricycle to its most compact position, use its handles to angle the front wheel to fit past the left rear wheel and adjust the pedals so the left pedal will fit neatly between the spokes of the wheel.



 Be careful not to damage the wheels, spokes, or pedals in this process.

To unfold your tricycle for use, follow the same procedure in reverse. Again, be careful of damage to the parts at each step and always check that the hinge is fully in place and locked before starting to ride.

Speed Gearing Adjustment

The gear shifter on the right handlebar uses a twist grip to control the 7 rear cogs, providing 7-speed gearing for manual riding.

Larger gear numbers represent smaller cogs and higher speeds.

Smaller gear numbers refer to larger cogs and lower speeds.

To upshift, turn the twist grip forwards (toward +).

To downshift, turn the twist grip backwards (toward -).

Be sure that your tricycle's crank is turning while using the shifter to adjust the long chain on the cogs.

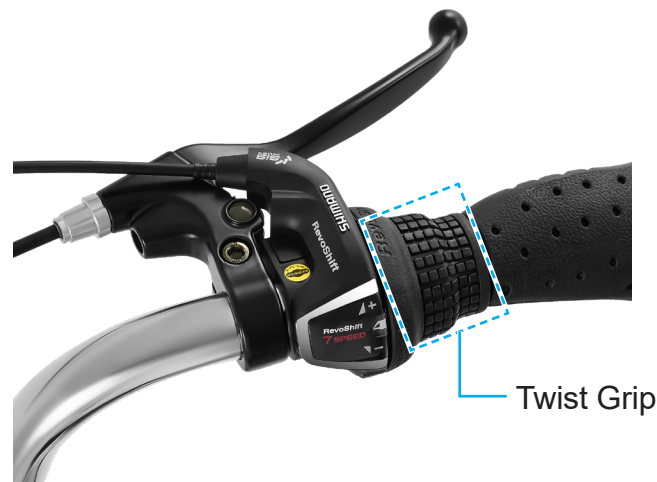

Maintenance

- Check the parts of the tricycle for any looseness, wear, or damage after use. Tighten, repair, or replace any problematic parts before further use.
- The exterior of the tricycle can be cleaned with a soft damp cloth. Do not use abrasive or caustic chemicals.
- Lubricate the chain and any moving part using a standard bike lubricant as needed.
- If the tricycle will not be used for an extended period of time, store in a cool dry place away from direct sunlight and inaccessible to children.

Contact Us

Thank you for choosing our products! If you have any questions or comments, contact us at contact@b2ccsonline.com and we'll resolve your issue ASAP!

For a .pdf copy of the latest version of these instructions, use the appropriate app on your smartphone to scan the QR code to the right.



ABF-R1AB-AB ABF-R1AB-AC
ABF-R1AB-AG ABF-R1AB-AR
ABF-R2AB-AB ABF-R2AB-AC
ABF-R2AB-AG ABF-R2AB-AR