



Mini Crawler Excavator User Manual



Read Carefully Before Use
Keep for Future Reference

Preface

Congratulations on your new mini excavator!

Welcome to the user manual for the mini excavator. We are thrilled to provide you with a comprehensive guide on operating and maintaining this powerful and versatile machine. Whether you're a seasoned professional or a newcomer to the world of construction and excavation, this manual is designed to be your reliable companion throughout your journey with the mini excavator.

Within these pages, you'll find detailed instructions, safety guidelines, and valuable tips to ensure that you operate the mini excavator efficiently, effectively, and most importantly, safely. We aim to empower you with the knowledge and confidence needed to harness the full potential of this equipment while prioritizing the well-being of both yourself and those around you. From assembling and starting up the mini excavator to executing complex digging and lifting tasks, we've covered every aspect to make your experience seamless. Additionally, you'll discover insights into routine maintenance procedures that will keep your mini excavator in prime condition, prolonging its lifespan and optimizing its performance.

Safety is paramount, and we emphasize the importance of adhering to the provided guidelines. This manual clearly explains safety protocols, operational best practices, and hazard mitigation techniques. By prioritizing safety, you're protecting yourself and creating a secure environment for your team and job site.

Remember, this manual is not just a technical document; it's a guide tailored to your needs. We encourage you to familiarize yourself with its content, explore its sections, and refer back to it whenever needed. Our commitment is to empower you with the knowledge necessary to make the most of your mini excavator, elevating your capabilities and contributing to successful projects.

Thank you for choosing our mini excavator. Your journey starts here, and we're excited to embark on it together. Let's dig in!

Disclaimer

Read this disclaimer **BEFORE** use.

1. **As-is**

This product(s) is sold 'as is' and without any express or implied warranties, including but not limited to the implied warranties of merchantability and fitness for a particular purpose.

2. **Product Modifications**

Any modifications or alterations to AHM products void any warranties and may result in damage or injury. AHM shall not be liable for any damages resulting from such modifications or alterations.

3. **Compliance with Laws**

Customers shall be liable for ensuring that the use of AHM products complies with all applicable laws and regulations in their respective jurisdictions. AHM assumes no responsibility for any violations of laws or regulations resulting from the use of its products.

4. **Correct Use**

Always use the product(s) only as directed in the accompanying manual. Failure to follow instructions may result in injury or damage.

Always ensure the operation, installment, maintenance, and repair of the product(s) is carried out by a competent person.

Always make maintenance regularly throughout the product lifecycle, you have the liability to keep the product operating as intended.

Always wear appropriate protective gear.

5. **Third-Party Products**

AHM shall not be liable for any damages or losses resulting from the use of third-party products in conjunction with our products. Customers should refer to the third-party's guidelines or/and warranties (if any) for any third-party products used.

6. **Limitation of Liability**

AHM shall not be liable for any direct, indirect, punitive, incidental, special, or consequential damages to property or life, whatsoever arising out of or connected with the use or misuse of our product(s). In no event shall AHM's liability exceed the value of the product(s) sold.

This disclaimer states the entire obligation of AHM with respect to the products. If any part of this disclaimer is determined to be void, invalid, unenforceable, or illegal, including, but not limited to the warranty disclaimers, liability disclaimers, and liability limitations set forth above, then the invalid or unenforceable provision will be deemed superseded by a valid, enforceable provision that most closely matches the intent of the original provision and the remainder of the agreement shall remain in full force and effect.

Contents

1	About the Machine	1
1.1	Work Equipment Compatibility	1
2	Safety Information	2
2.1	General Safety	2
2.2	Operation Temperature Safety	2
2.3	Personal Safety	3
2.4	Operation Safety	4
2.4.1	General Operation Safety	4
2.4.2	Travel Safety	6
2.4.3	Load & Unload Safety	11
2.4.4	Excavation Safety	12
2.4.5	Hoisting Safety	13
2.4.6	Hydraulic Cylinders Safety	14
2.4.7	Water Safety	16
2.4.8	Mud Escaping	17
2.4.9	Parking Safety	17
2.4.10	Oil Safety	18
2.4.11	Maintenance Safety	18
3	Specifications	22
4	Product Diagram	23
5	Package List	24
6	Installation	25
6.1	Installing the Cab Roof	25
6.2	Changing the Attachment	26
7	Operation	27
7.1	Starting the Engine	27
7.2	Using the Headlights	28
7.3	Using the Excavation Timer	28
7.4	Forward & Backward Travel & Steering	29
7.5	Basic Excavation	30
7.6	Basic Bulldozing	32
7.7	Leveling	32

7.8	Transportation	33
8	Maintenance	34
8.1	Checks before Maintenance	34
8.2	General Maintenance Schedule	35
8.3	Greasing, Replacement & Periodical Check Schedule	35
8.4	Work Equipment Pins Lubrication	36
8.4.1	Locations of Work Equipment Pins	36
8.4.2	Lubricating the Slew Bearing	37
8.4.3	Lubricating the Meshing Gear of Slew Bearing	37
8.5	Engine Maintenance	37
8.6	Greasing, Replacement & Periodical Check Schedule	38
8.7	Hydraulic System	38
8.7.1	Checking the Hydraulic Cylinders	38
8.7.2	Checking the Hydraulic Oil Level	40
8.7.3	Refilling the Hydraulic Oil	40
8.7.4	Replacing the Hydraulic Oil Suction Filter Element	41
8.7.5	Checking Hoses & Pipelines	41
8.8	Checking the Battery	42
8.9	Checking the Bucket Teeth	42
8.10	Checking the Bolts and Nuts Tightening Torque	43
8.11	Miscellaneous Checking Schedule	43
8.12	Checks after Maintenance	44

1 About the Machine

This excavator is versatile and applicable to farming, landscaping, ditching and fertilization in gardens, vegetable greenhouses, agricultural transformation, indoor demolition, small earthwork, civil engineering, road recovery, basement and indoor construction, concrete breaking, cable burying, water supply line laying, garden cultivation, desilting, and the like.

Your excavator is designed for lasting performance, featuring a robust KUBOTA diesel engine. With this trusted engine, you can expect durability and consistent power for your operations.

Moreover, the versatility of this excavator extends to its compatibility with a wide range of work equipment. Whether you require a quick hitch, log grapple, ripper, leveling bucket, auger, or narrow bucket, this excavator can serve your needs.

1.1 Work Equipment Compatibility

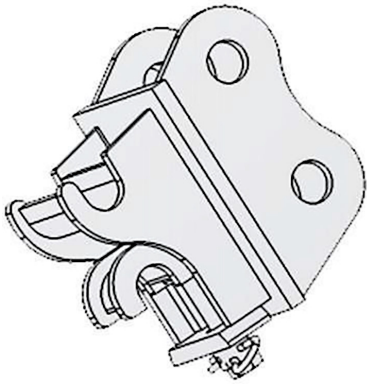

Quick Hitch

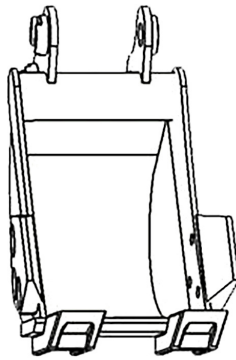

Narrow Bucket

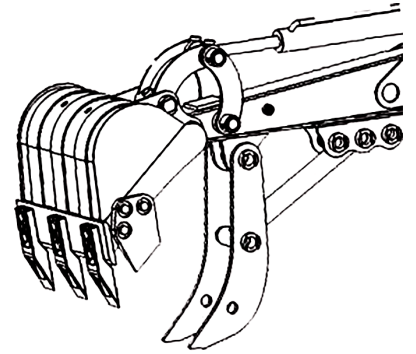

Mechanical Thumb

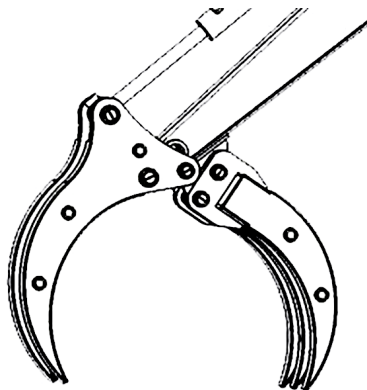

Log Grapple

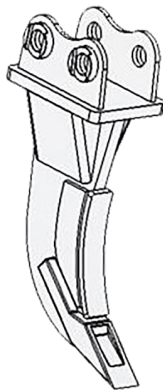

Ripper

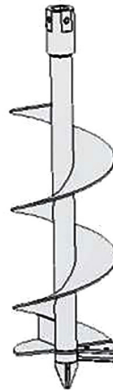

Auger

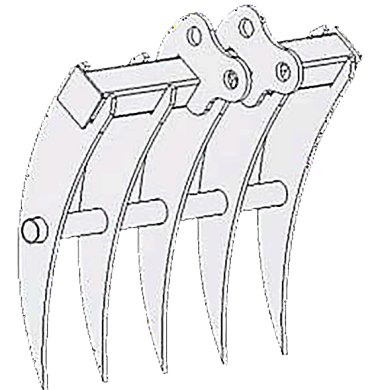

Rake

2 Safety Information

2.1 General Safety

- **ALWAYS** follow federal, state and local laws, codes and regulations concerning the use of construction machinery.
- Read this manual before actually operating the excavator. Familiarize yourself with the instructions that provide crucial information about the specific model's controls, maintenance requirements, and safety precautions.
- **ONLY** guarantee or allow persons with holistic knowledge of the safe operation of an excavator to operate, inspect or maintain the excavator.
- Strictly follow all the precautions and safety information as mentioned in this manual when operating, inspecting and maintaining the excavator.
- **DO NOT** operate, inspect or maintain the excavator when alcohol, drugs, medicines, fatigue, or lack of sleep impair your faculties or judgment. **NEVER** allow any persons under such conditions to operate, inspect or maintain this heavy machinery.
- Operating heavy equipment requires your full attention. Avoid distractions and remain focused on the task at hand.
- **IMMEDIATELY** cease use and contact Customer Service if the excavator shows any signs of anomalies or malfunctions, say noise, vibration, odor, leakage, error alarm, etc. **NEVER** attempt to resume using the excavator if the issues remain unsolved.

2.2 Operation Temperature Safety

Warning

- For proper functioning and expected performance of the excavator, **DO NOT** operate the excavator if the ambient temperature is higher than 113 °F (45°C) or lower than 5°F (–15°C).
Operating the machine under an ambient temperature higher than 113 °F (45°C) can cause the engine to overheat, compromise your energy efficiency, and shorten the hydraulic system's service life.
- If the excavator works at an ambient temperature below 5°F (–15°C), the gaskets and other rubber parts may freeze or harden, causing early and excessive wear to the excavator.
- Under cold temperatures, the excavator may take some time to warm up before working normally. After starting the engine, let it run idle for a couple of minutes and allow all systems a few minutes to get ready.
- **ONLY** use the rubber track at temperatures between –13 to 131°F (–25 to 55°C)
- If the excavator must work in such conditions, please consult Customer Service.

2.3 Personal Safety



Warning

- **DO NOT** wear loose clothes or accessories that may get caught in the moving parts of your excavator in operation. Wear clothes that are oil-repellent. Replace them if grim or grease start to build up. Fabrics coated or soaked with grim can burn in proximity to heated machinery.
- **ALWAYS** use personal protective equipment (PPE) suitable to your task. Always wear ANSI and OSHA-approved eye, breathing, and hand protection while using this product. Nonslip and steel-toe footwear is also highly recommended. Other equipment such as ear, head, and body protection may also be necessary depending on your work, work environment, and other equipment.
- **ALWAYS** keep a fire extinguisher and first-aid kit in an easily accessible place.

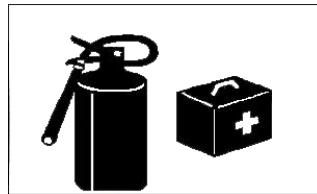

- Familiarize yourself with the protocols for using the first-aid kit and operating the fire extinguisher. Ensure that you provide training to other individuals who will be operating the excavator. This ensures that everyone is prepared to handle potential emergencies effectively.
- Display the contact details of the nearest Emergency Room (ER) prominently in the operator's area. Make sure that all personnel operating the excavator are well-informed about this information.
- Do not operate with the cover of the cab removed. Ensure the protective barriers, guards, screens, or covers are properly installed and secured before operating the excavator. Do not remove any safety devices except when inspecting and servicing the excavator. Always check that the safety devices are in good condition before operating.

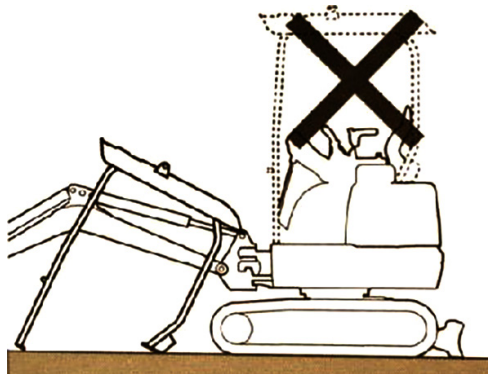

2.4 Operation Safety

Warning

2.4.1 General Operation Safety

- Due to the nature of construction work, using a signalman or flagman is necessary. Always ensure that you and any person involved fully understand the gestures and signals used by your signalman or flagman. If such a communication fails at any time, use an intercom communication.



- Prior to commencing any operations, run a comprehensive drill rehearsal to ensure that every participant comprehends, can effectively respond to, and proficiently practice both the designated signals and emergency protocols.
- Clean the soles of your shoes of any dirt, grease, or gravel on your soles before going into the cab. Operating the excavator pedal with dirt and grease on the soles may result in uncontrollable throttle or accidental falling from the cab.
- **NEVER** place any plastic or glass bottle in the cab, which could catch fire.
- **ALWAYS** lower your working device to the ground and shut the engine down before leaving the driver's seat. Store the key(s) in a designated place that is inaccessible to unauthorized use.

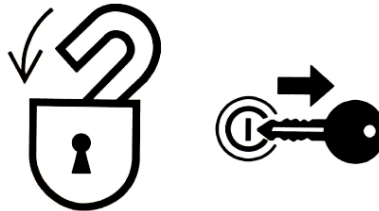

- **ALWAYS** check that the control rod/joystick is in neutral before starting or stopping the engine.
- Do not enter or exit the excavator by jumping. **ALWAYS** mount the excavator as depicted. **NEVER** attempt to get on and off a moving excavator. **NEVER** use the control rod/joystick as a handle.
- If the excavator must work in such conditions, please consult Customer Service.



- **NEVER** carry any persons with the excavator.



- **ALWAYS** circle the excavator to check for anomalies before entering the cab and operating.
- **ONLY** start the excavator when no one is within its operation radiuses.
- **NEVER** start the engine if you see a “**DO NOT OPERATE**” warning label or similar signs in the driver’s cab, the control rod, or the start switch.
- **NEVER** move the bracket over any person. Debris falling off could cause serious injuries or even death.

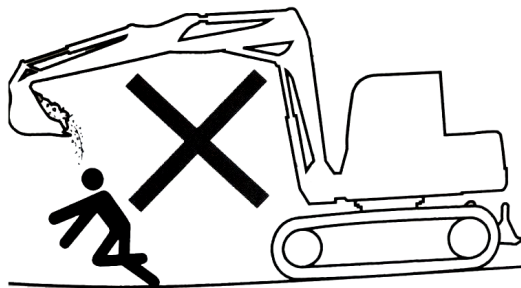

- **ALWAYS** visually check that the dozer is in front of the driver's seat before operating. If the dozer is at the rear of the driver’s seat, the controls for turning and traveling will operate in reverse, contrary to the intended direction for the excavator's movement.

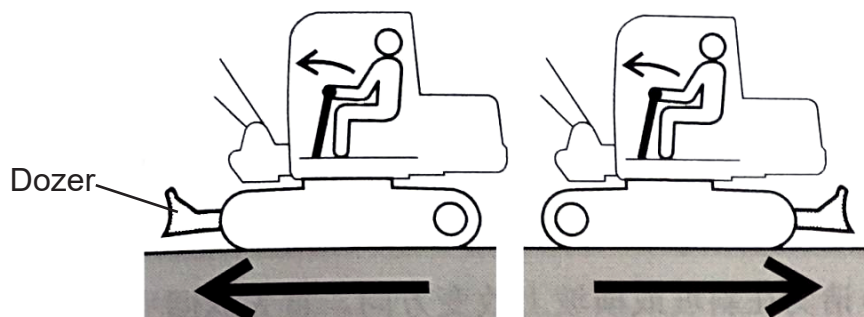

- **DO NOT** operate on soft or damp soil ground, on which this excavator may tilt or fall over. **DO NOT** operate on unstable ground. If the ground vibrates or shakes as you drive over, cease driving and exit the excavator immediately.

- This excavator is designed for digging, bulldozing, and ditching. It has no compatible apparatus for hoisting. Consult a professional before operating this excavator for that purpose.

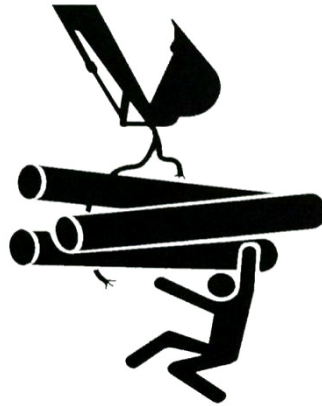

- **ALWAYS** know the locations of obstacles such as ditches, utility lines (like gas, power, and water), and things that might fall (like trees, overhead wires, or stones on a cliff).

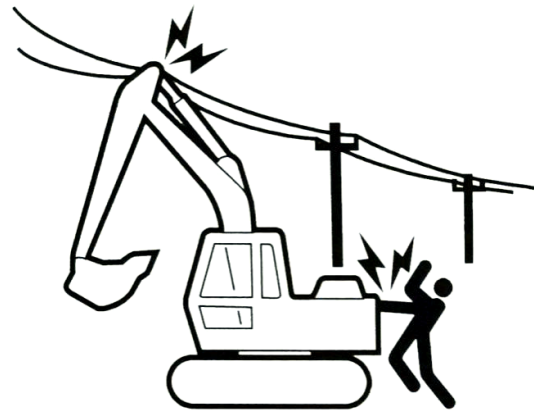
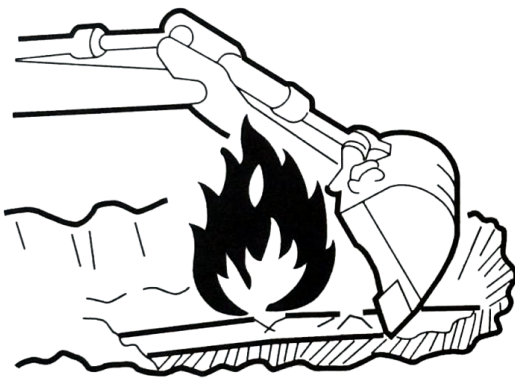

2.4.2 Travel Safety

- **ALWAYS** check with the signalman or flag man that no person is standing within the operating radius of the excavator.

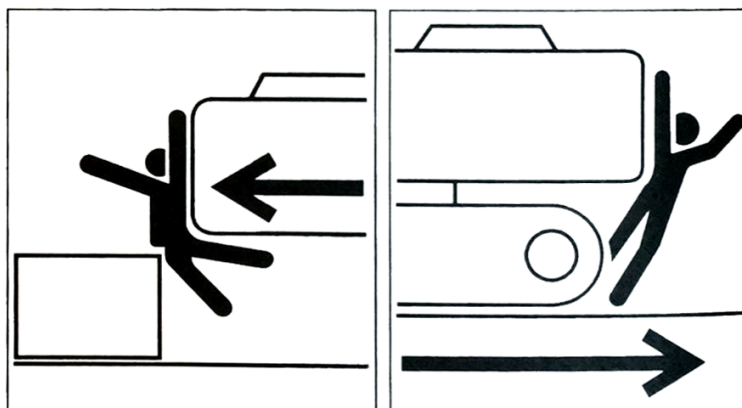

Safety Information

- **ALWAYS** confirm that there is no obstruction before the dozer that may topple the excavator while traveling. Raise the dozer and bucket as shown above the ground by 30 cm to 40 cm, depending on the specific terrain.

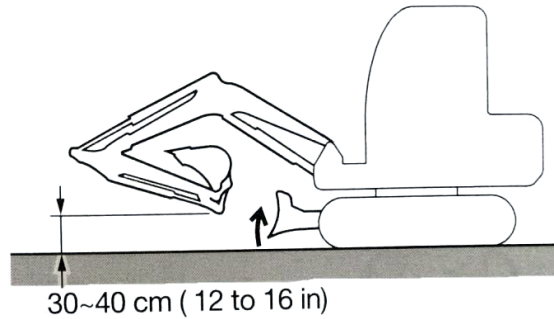

- **AVOID** traveling as shown below. Lower the dozer closer to the ground and travel slowly if you must. **DO NOT** attempt to climb obstacles that will tilt the excavator to an angle of 10° or higher.

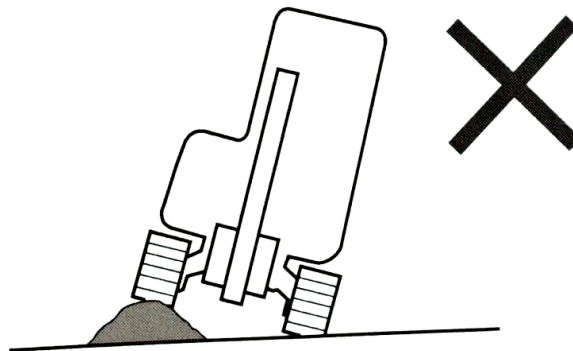

- Maintain a low speed while traversing rough terrain; avoid abrupt starts, stops, or sudden changes in direction. Such actions could cause the working device to come into contact with the ground, jeopardizing the excavator's balance and potentially causing harm to nearby structures.
- Exercise caution when navigating slopes. Ensure the excavator's stability when moving on slopes or inclines. Refrain from operating on excessively steep slopes where the excavator's stability is compromised (maximum angle: 30°, lateral tilt: 10°). The excavator's stability can vary depending on the specific work conditions, potentially falling below the mentioned values.
- Before traveling downhill, swing the cab 180° so the dozer is at your back. Adjust the arm and boom in the position as shown, and pay close attention to the slope ahead.

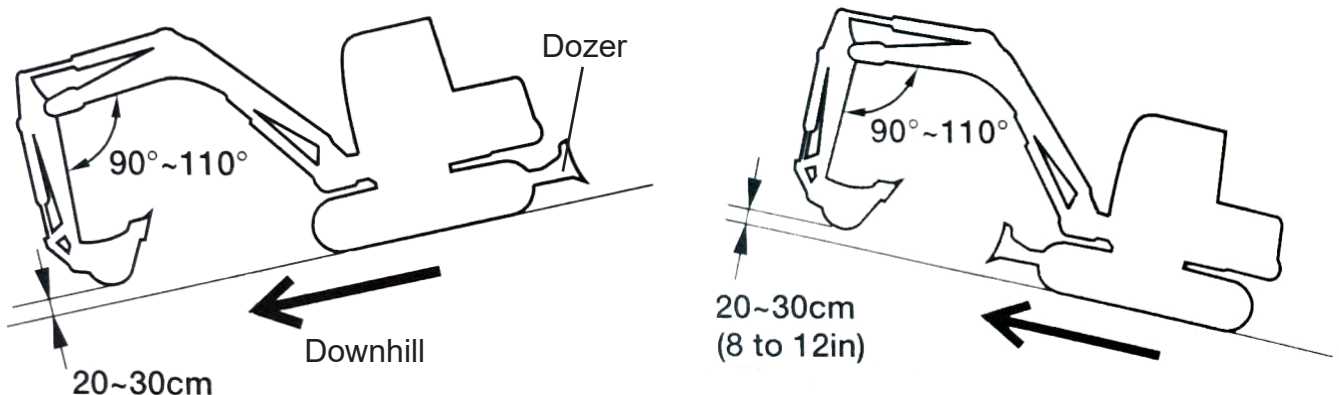

- Before traveling uphill, lower the dozer and bucket to 20–30 cm above the ground and ensure the dozer is ahead. Lower the dozer into the ground and shut down the excavator in case of emergency.
- **NEVER** go backwards on slopes. The arm and boom are heavier than the cab when equipped with a crashing hammer, crusher, or a long bucket rod. **DO NOT** dig or operate laterally with a rod (boom) toward the downhill direction.
- Avoid altering your direction while on a slope or a cross slope. Instead, navigate back to level ground before selecting a new path. This approach helps maintain stability and safety during directional changes.

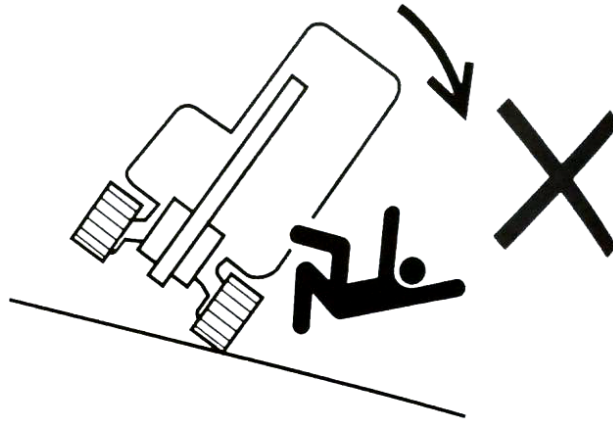

- **NEVER** swing the cab on slopes. The excavator is more susceptible to rolling in the lateral direction than the longitudinal one. Exercise caution when executing lateral turns (swings) when the bucket is heavy. **NEVER** swing the cab abruptly when the bucket carries a heavy load, even on level ground.

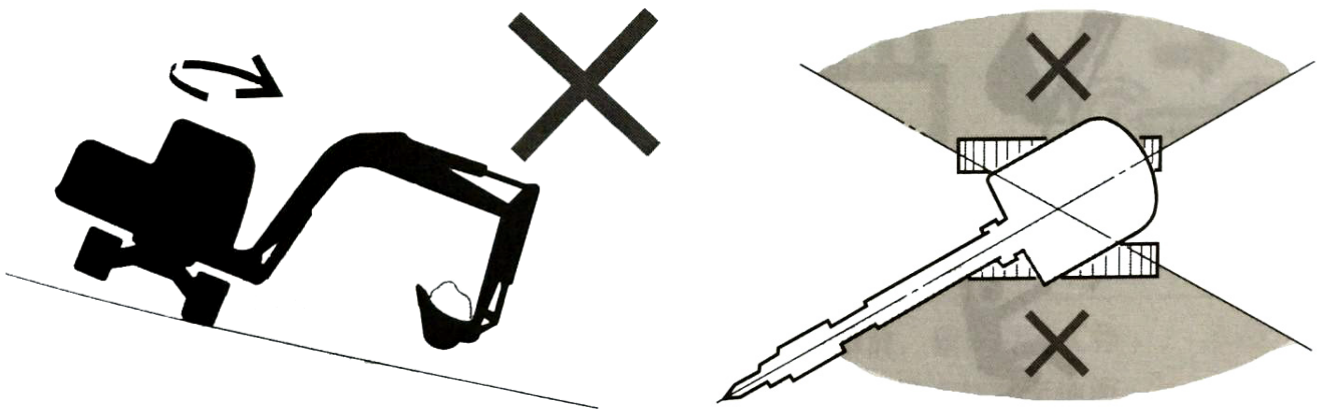

- While moving across gentle slopes covered with grass, leaves, or on wet metal plates or frozen ground, be cautious of potential slipping hazards. Ensure the excavator is not positioned sideways on the slope to prevent unintended slipping incidents.
- Exercise **EXTREME CAUTION** when operating the excavators on snow or ice. Objects on the road shoulder or roadside may be concealed beneath the snow, rendering them invisible. This poses a risk of the excavator overturning or colliding with these snow-covered objects. Therefore, exercise caution while operating the excavator in such conditions. Consult professional advice on operating an excavator under extreme weather conditions.

- Steer clear of entering areas with soft ground, as the excavator's weight may induce tilting, leading to the risk of collapse or sinking. If you find it necessary to operate in such conditions, it's advisable to seek professional guidance or assistance beforehand.

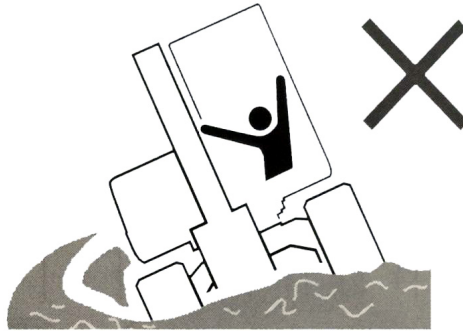

- **ALWAYS AVOID** driving and turning on gravel, highly uneven hard rock, steel beams, scrap iron, or near the edge of a plate, can damage the rubber track.



- Navigating across riverbeds or ground with gravel could lead to gravel becoming lodged in the track, potentially causing track damage or derailment. Refrain from utilizing this excavator in marine environments. The salt content may corrode the steel track core.

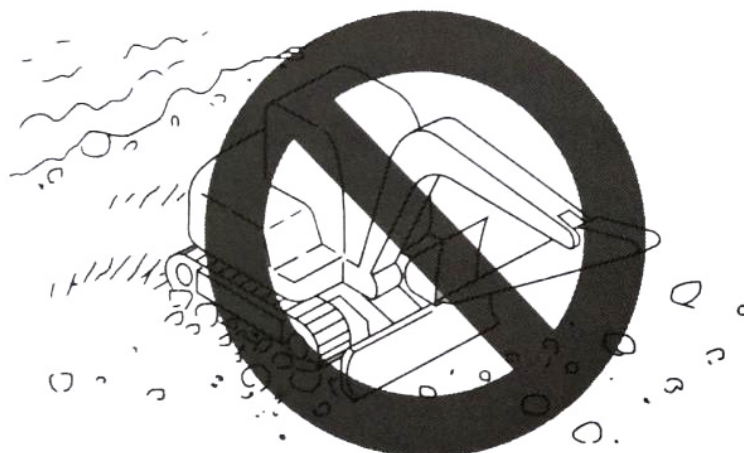

- **DO NOT** travel on newly paved asphalt roads or similarly heated surfaces, as this **WILL** compromise the service life of the rubber track. **NEVER** travel with the rubber track removed for better traction, as this **WILL** shorten the service life of the sprockets.

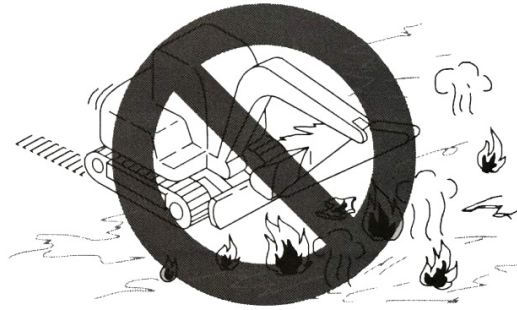

- Due to the rubber composition of the entire track, rubber tracks may not offer the same stability as steel tracks. Exercise caution during lateral turns and swings.

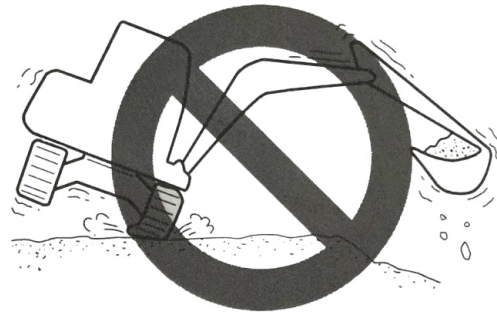

- When the vehicle encounters obstacles like pebbles, rocks, or other substantial steps (20 cm or higher), ascend at a perpendicular angle without changing direction on the steps.



- **DO NOT** change the direction as you go up a slope.

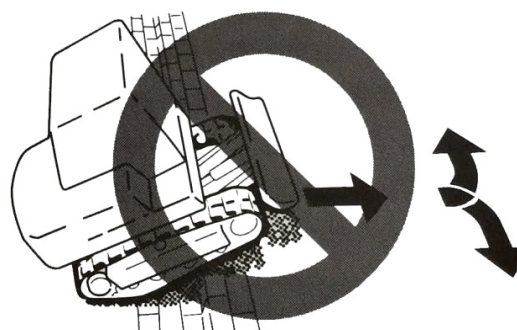

- Refrain from positioning one track on a slope or protruding surface while the other track is on a flat area (where the excavator inclines 10° or higher). Travel with both tracks on the flat surface.



- **NEVER** change direction or swing the cab when the track is loose, as shown. If the excavator travels in reverse, the sprockets **WILL** derail from the rubber track. Similarly, the track **WILL** detach if you swing the cab in any direction.

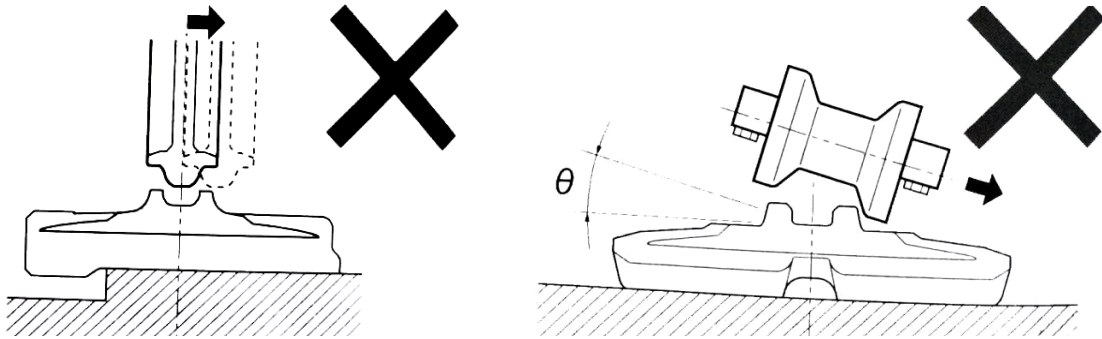

2.4.3 Load & Unload Safety

- **NEVER** raise the bucket over any persons, not even a driver sitting in the cockpit.
- **ALWAYS** ensure the driver's safety when loading. Do not apply the load until the driver arrives at a safe place. **ONLY** load/unload from the back of a vehicle.

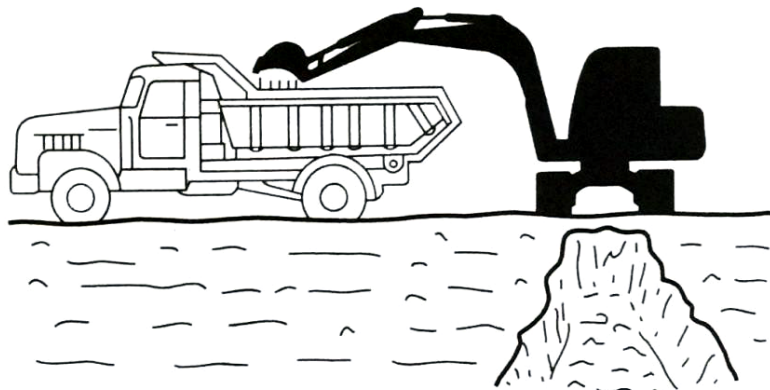

2.4.4 Excavation Safety

- **NEVER** excavate at the base of steep embankments, as this can trigger ground subsidence and pose significant risks. Refrain from operating the excavator in areas prone to falling rocks or debris, as this presents a hazardous environment.

Keep a safe distance between the excavator and the edge of the site. **NEVER** dig the ground in front of the excavator when near an edge.

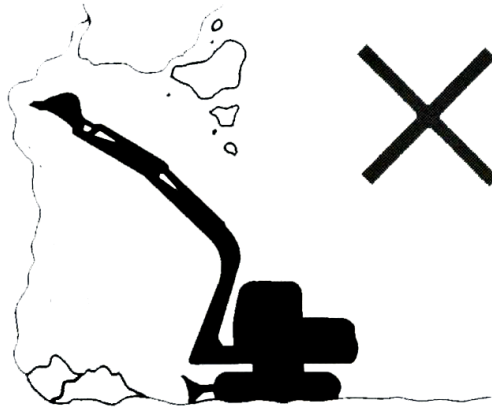

- Refrain from disassembling components underneath the excavator. The unstable ground could result in the excavator tipping over. Before operating atop a building or other structure, thoroughly assess their strength and structural integrity. In the event of a collapse, it could lead to substantial damage or destruction.

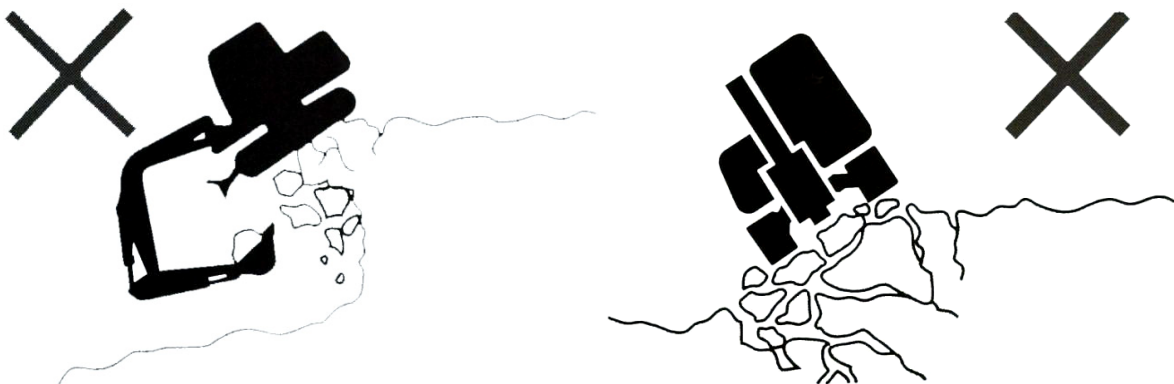

- Avoid excavating from an elevated position. This poses a risk of objects falling or buildings collapsing, potentially causing severe injuries or significant destruction.

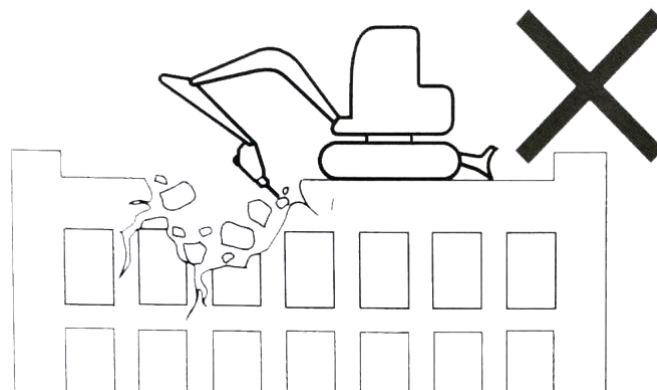

- **NEVER** disassemble from under a bridge or similar structures, as you can be crushed with brutal force—causing severe injuries, death, or significant destruction.

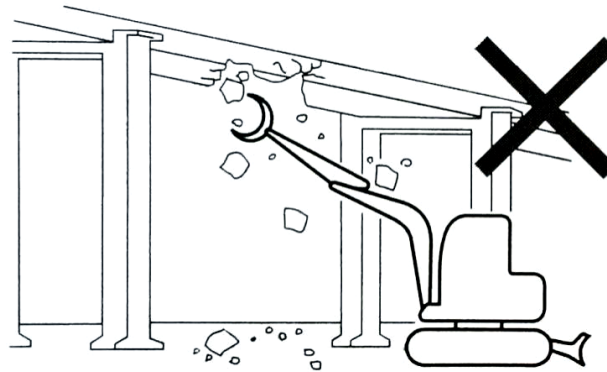

- **NEVER** use the boom and arm to swing and smash against structures for demolition purposes. This action can propel heavy debris forcefully, leading to substantial property damage, severe personal injuries, or even loss of life.

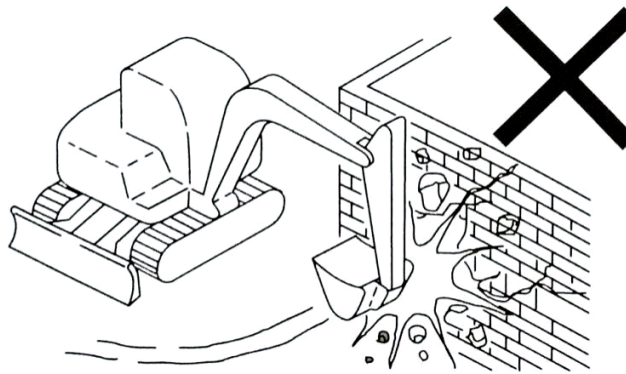

2.4.5 Hoisting Safety

- All rated lifting capacities are determined under the assumption of stable and level ground conditions. For secure lifting, users must incorporate appropriate safety margins when encountering specialized work conditions, such as soft or uneven terrain, non-horizontal surfaces, lateral loads, sudden or dynamic loads, hazardous environments, and personnel experience. Prior to operating the excavator, operators and other personnel must be well-acquainted with the operation manual and adhere strictly to the equipment's safety operation procedures.
- If the chain or hoisting device isn't properly connected, the bucket linkage or hoisting device might fail, leading to severe injury or even fatalities.
- While using the excavator as a crane, abstain from attempting to extract stumps from the ground, as the load on the excavator becomes uncertain under such circumstances.
- It is strictly prohibited for anyone to be positioned above, below, or near the lifted object, or within the vicinity of the working area. Exercise vigilance regarding airborne debris.
- This excavator lacks protective equipment to shield the operator from airborne debris. Hence, refrain from using this excavator in hazardous locations where the operator is susceptible to being struck by flying debris.

2.4.6 Hydraulic Cylinders Safety

- **DO NOT** extend the hydraulic cylinders past the max length.

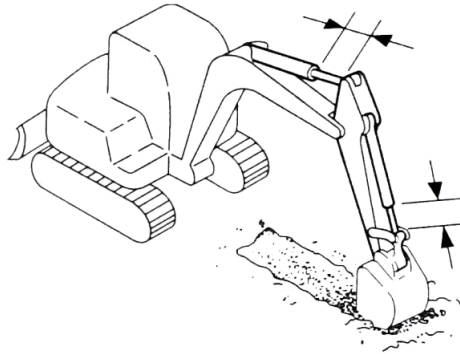

- **NEVER** raise the whole excavator by lowering the dozer. The entire weight of the excavator and driver **WILL** damage the dozer cylinder. **NEVER** use the dozer for digging.

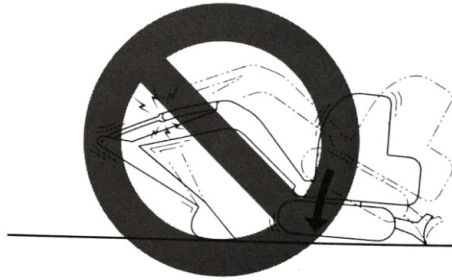

- **AVOID** forcefully striking the bucket against the ground. This **WILL** damage the boom and arm cylinders, along with other crucial connections.



- **DO NOT** use the boom and arm to support the full weight of the excavator, as this **WILL** damage the hydraulic systems and pose a hazard to the operator and other personnel.



Safety Information

- When dealing with hard rock, employ a crushing hammer (not included) to break the rock into smaller fragments. This approach safeguards the excavator from potential damage and proves more cost-effective.

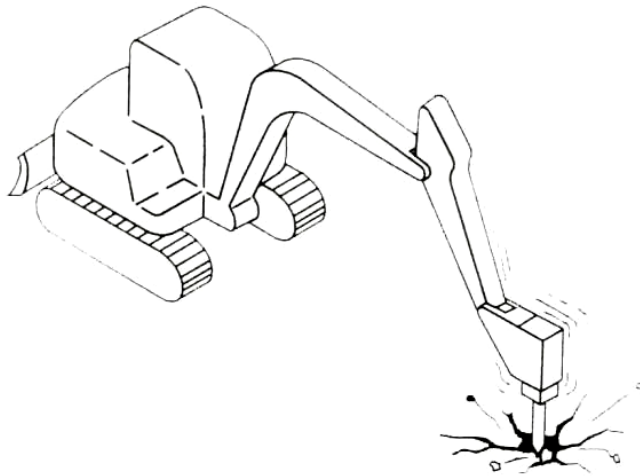

- Striking rocks with the dozer can damage both the dozer and its cylinder. Take caution when retracting the dozer.



- Pay attention to the position of your dozer's control rod when digging. Make sure the dozer doesn't drop accidentally.



- When deep digging with the front blade, exercise caution to prevent collision to the boom, dozer, and bucket. Swing the cab so the dozer is at the rear. Exercise caution as you dig, being careful not to carry too heavy a load.



2.4.7 Water Safety

- **NEVER** submerge the cab in water. This will immerse the radiator and burn it. If you must operate in water, ensure the water doesn't cover the whole track. Apply sufficient lubricating oil for any parts that have been underwater when on land.

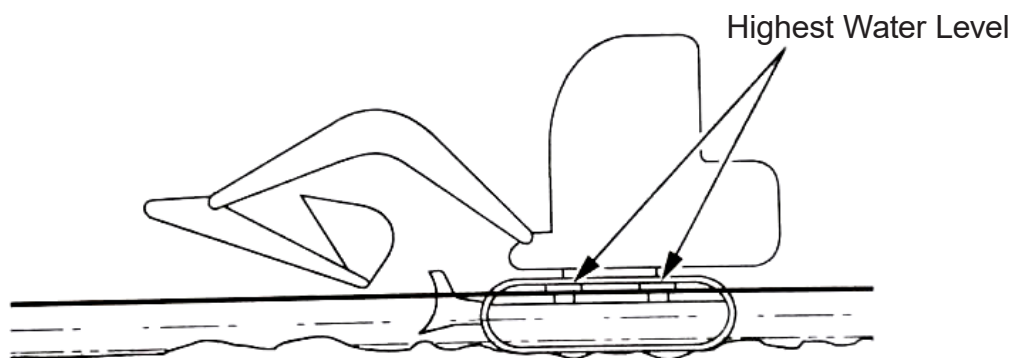

- **ONLY** wade through water when you know it cannot compromise the safe operation of the excavator and your personal safety. Drive through at a stable, slow speed.

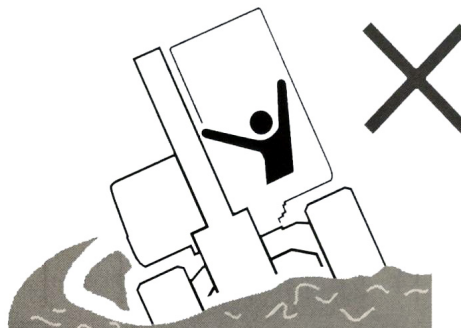

2.4.8 Mud Escaping

One-Track Entrapment

Follow the steps below to escape mud entrapment.

1. Check if just one of the tracks is trapped. If so, proceed to the next step. If not, see the below for both tracks' entrapment.
2. Set the angle between the arm and boom to somewhere between 90° and 110°.
3. Retract the bucket, lay the bottom against sturdy ground, and raise the bucket to raise the whole excavator up.
4. Lay a sturdy plank under the raised track. Raise the bucket and move out of the entrapment.



Two-Track Entrapment

1. Repeat steps 1–3 in One-Track Entrapment.
2. Lay two sturdy planks or similar-shaped objects under the lifted tracks, ensuring the planks are inserted into the end of the tracks.
3. Use the bucket as a leverage point while traveling out of the entrapment.



2.4.9 Parking Safety

- Park the excavator on flat, solid, safe ground if possible. If such a parking surface is unavailable, make sure you park it as shown.

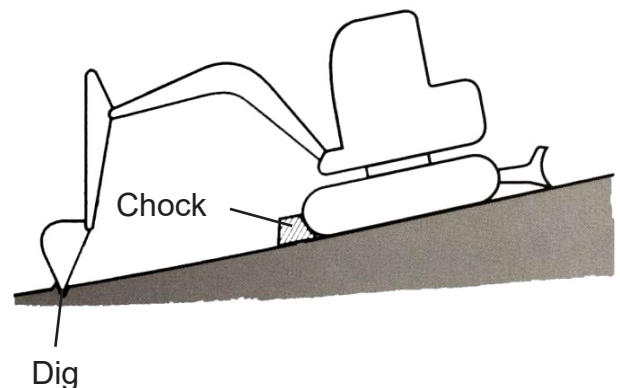
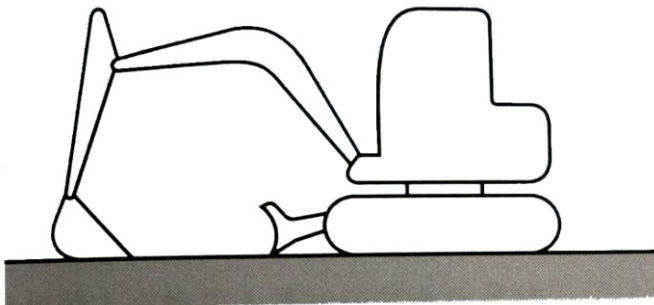

2.4.10 Oil Safety

- **DO NOT** remove the fuel tank cap or fill the fuel while the engine is running or still hot. When filling oil, watch out not to splash the oil onto the excavator's hot surfaces or electronic components.
- Smoking should be **PROHIBITED** on the worksite.
- **IMMEDIATELY** clean the fuel or lubricating oil overspills.
- **AWLAYS** wait till the engine has cooled before refueling. Always fill the fuel tank in a well-ventilated location. Refuel carefully and clean overspills or splashes **IMMEDIATELY**.
- Avoid filling the fuel tank to maximum capacity; leave room for oil expansion. Immediately address any fuel spillage. Ensure the fuel tank is securely fastened. If the tank cover is absent, replace it with an identical one. Refrain from using unauthorized tank covers that lack proper ventilation, as this could lead to internal pressure buildup.
- For better engine performance and longer service life, consistently use clean and high-quality fuel. In cold weather conditions, opt for diesel oil that can function efficiently at temperatures of at least 12°C lower than the anticipated minimum outdoor temperature to prevent freezing.
- Use diesel oil with a cetane value of 45 or higher. In cold regions or areas at high altitudes, opt for fuel with a higher cetane value.
- Ensure that the fuel used contains sulfur content below 0.05–0.0015%. In the United States or Canada, employ ultra-low sulfur fuel. The use of high-sulfur fuel may result in acid corrosion of the engine cylinder.
- Avoid the use of kerosene. Refrain from mixing kerosene, used lubricating oil, residual fuel, or other additives with diesel oil. Poor-quality fuel can undermine engine performance or cause damage.
- Fuel additives are not recommended, as some additives may degrade engine performance. Additionally, metals like zinc, sodium, magnesium, silicon, and aluminum should be limited to one part per million (1 ppm mass) or less.
- When utilizing bio-diesel, adhere to safety guidelines. Warranty provisions from the engine manufacturer may become void if the excavator does not meet the required standard or if deteriorated bio-diesel is used.

2.4.11 Maintenance Safety

- **ONLY** replace damaged parts with identical ones. If such parts can't be procured locally, contact Customer Service.

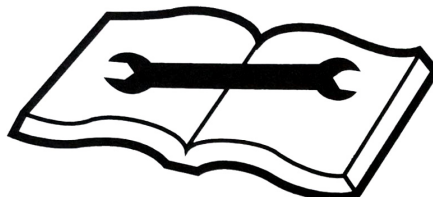

- **ONLY** replace damaged parts with identical ones. If such parts can't be procured locally, contact the Customer Service.
- **DO NOT** modify the excavator. Unauthorized retrofitting of the excavator may cause injury or even death, for which the manufacturer and importer of the excavator will not be held liable.
- **ALWAYS** check that the labels and signages are legible. If damaged, replace them with identical ones.

Safety Information

- **ALWAYS** keep the excavator clean, especially parts that the driver steps on or holds on to. Wipe grim, grease, dirt, snow, or ice off of them to prevent accidental falling.
- **ALWAYS** check the inlets and outlets of the engine for any obstructions.

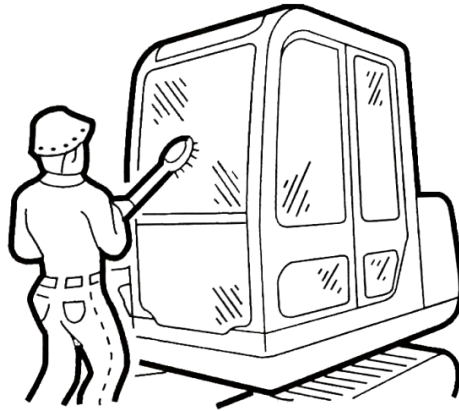

- Prevent fuel, lubricating oil, salt, or chemical solvents from coming into contact with the track. These substances can corrode the welding seams of the track steel core, leading to rust or detachment. Should any of these substances adhere to the track, promptly rinse it off with water.

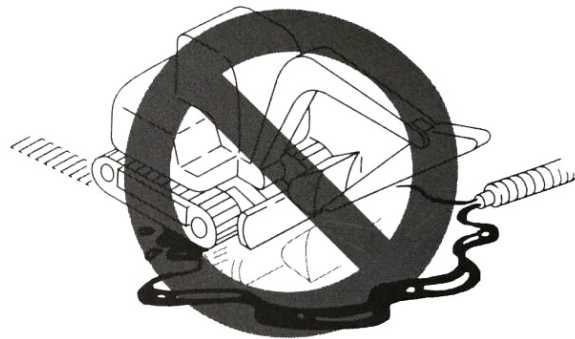

- **ALWAYS** mark the excavator with a “**DO NOT OPERATE**” sign if any malfunction arises. Hang the sign in a prominent location, preferably on the joysticks.



- Use explosion-proof lamps when examining fuel, lubricating oil, coolant, or battery electrolyte. Failure to do so could lead to severe injuries or fatalities caused by an explosion.



- **NEVER** use damaged tools, tools with poor performance, or tools with other purposes to service this excavator.

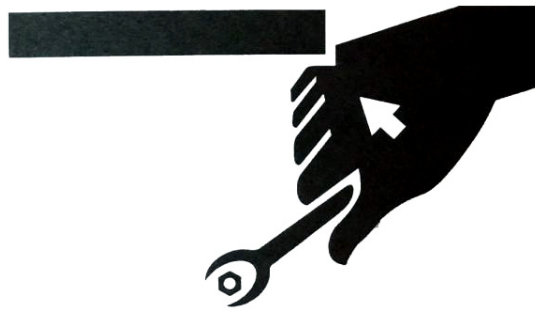

- **ALWAYS** be mindful of the rotating and moving parts. **NEVER** drop or insert any objects into a fan or fan belt, which could tear the objects into pieces and send them flying.

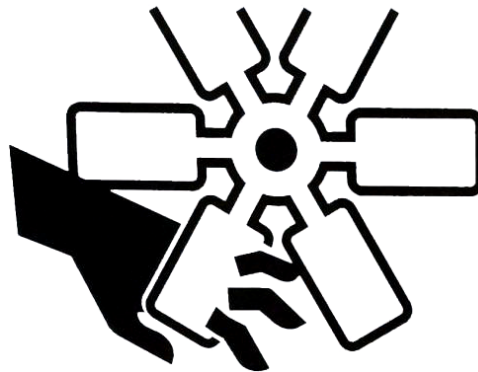

- **ALWAYS** lower all the movable working equipment onto the ground or at the lowest position before maintenance or repair under the excavator.



- **ALWAYS** make sure to immobilize the tracks using chocks before performing any work beneath the raised excavator or equipment. Always use a sturdy and stable support such as a wooden block or jack to ensure secure fixation. Do not engage in any work under the excavator or the working device if the equipment isn't stably fixed.
- **ALWAYS** secure the hood before servicing under it.

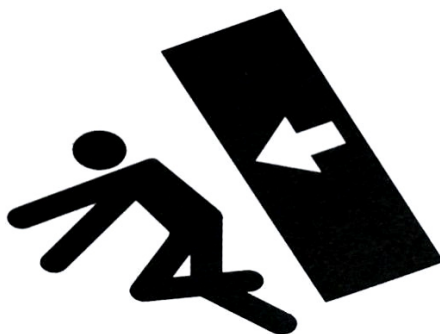

- When handling heavy objects or accessories during removal or installation, ensure they are secure and stable. Restrict unauthorized individuals from accessing the area where such items are stored.
- Refrain from lubricating or mechanically adjusting the excavator when the engine is active, even if the excavator is not operating. If maintenance must be carried out, use at least two operators. One should be seated in the driver's seat, prepared to promptly shut down the engine if necessary. Do not touch the control rods/joysticks. The other person performing maintenance should stay clear of moving parts.
- Salt, potassium chloride, ammonium sulfate, potassium sulfate, and lime superphosphate can damage the track. If any such substances stick to the track, clean it immediately with water.
- If the excavator will not be used for a prolonged period (three months or longer), disassemble the rubber tracks and store them away from direct sunlight or rain. You can also cover them completely with water-repellent canvas.

3 Specifications

Model		AX-15	
Engine	Model	KUBOTA D722	
	Rated Power	13.8 hp	
	Rated Speed	2600 rpm	
	Rated Torque	33.19 ft lb. / 45 Nm @ 2600 rpm	
	Displacement	43.9 in ³	719 cm ³
	Oil	105 fl oz	3.8 L
		10W-40	
Fuel Tank Volume		2.58 gal.	9.74 L
Max. Traveling Speed		3km/h	
Fuel Consumption		0.26 gal/h	1 L/h
Fuel Type		Diesel	
Main Pump	Model	PGP5106SLP	
	Rated Pressure	2610.28 psi	18 MPa
	Max. Pressure	3626.43 psi	25 MPa
	Nominal Flow	0.2 fl oz/r	6 ml/r
	Hydraulic Oil	AW 46	
	Oil Flow	4.23 gal/min	16 L/min
Slewing Speed		11 rpm	
Hydraulic Tank Volume		3.4 gal.	12.7 L
Travel Motor Model		BM6-310	
Track Width		7.1 in.	180 mm
Supporting Wheel No.		2	
Overall Track Length		48.5 in.	1230 mm
Platform Ground Clearance		16.2 in.	410 mm
Min. Clearance		3.8 in.	98 mm
Min. Swing Radius		62.2 in.	1580 mm
Bucket Volume		0.88 ft ³	0.025 m ³
Bucket Width		15.7 in.	400 mm
Overall Height		7.4 ft.	2240 mm
Max. Bucket Digging Force		2697.9 lbf	12 KN
Max. Passenger Capacity		264.5 lb.	120 kg
Max. Digging Depth		68.9 in.	1750 mm
Max. Vertical Digging Depth		61 in.	1550 mm
Maximum Dumping Height		62.6 in.	1590 mm
Max. Digging Radius		120 in.	3050 mm
Dozer Height		12.6 in.	320 mm
Max. Dozer Depth		7.8 in.	200 mm
Max Slope Grade		30°	
Weight		1940 lb.	880 kg

4 Product Diagram

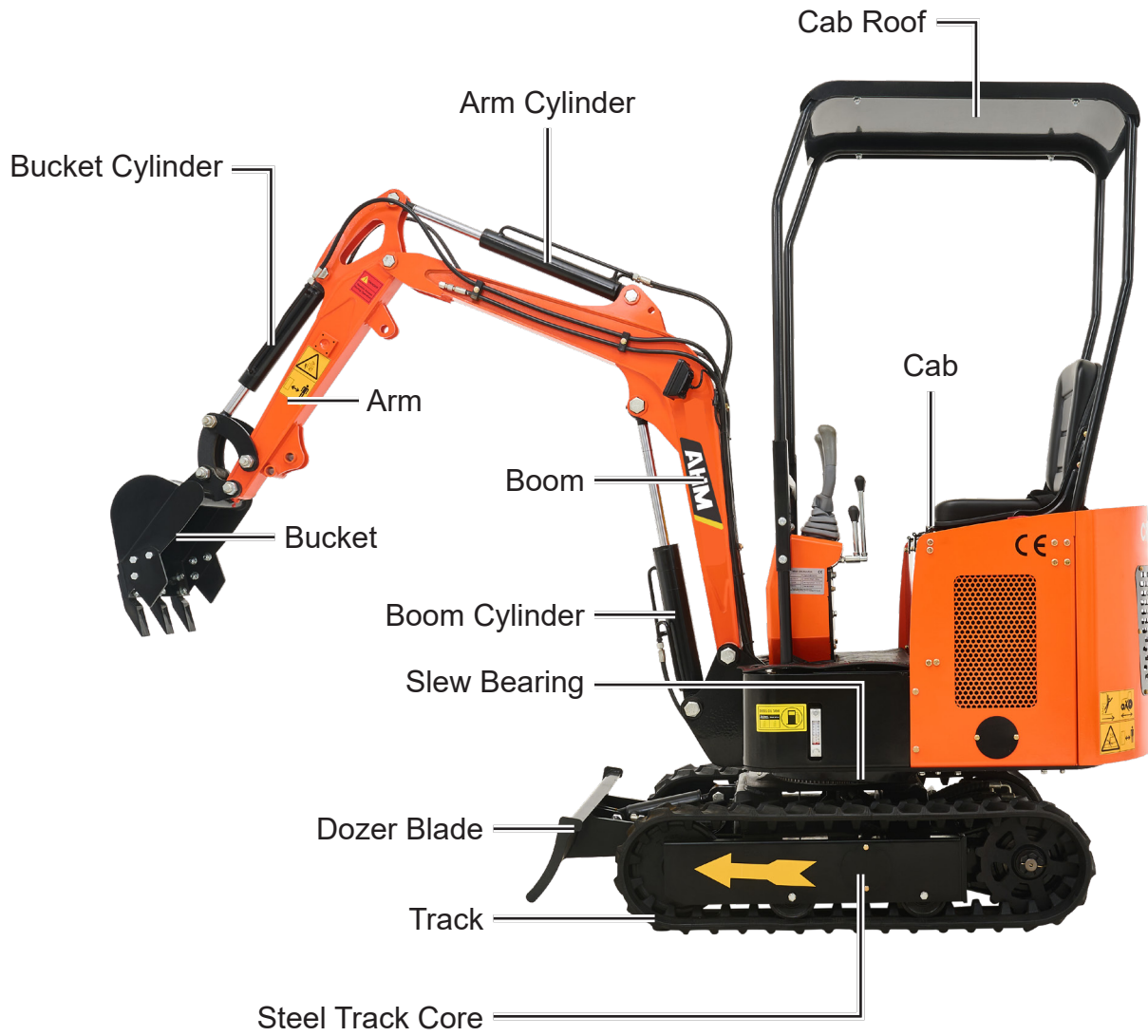

5 Package List

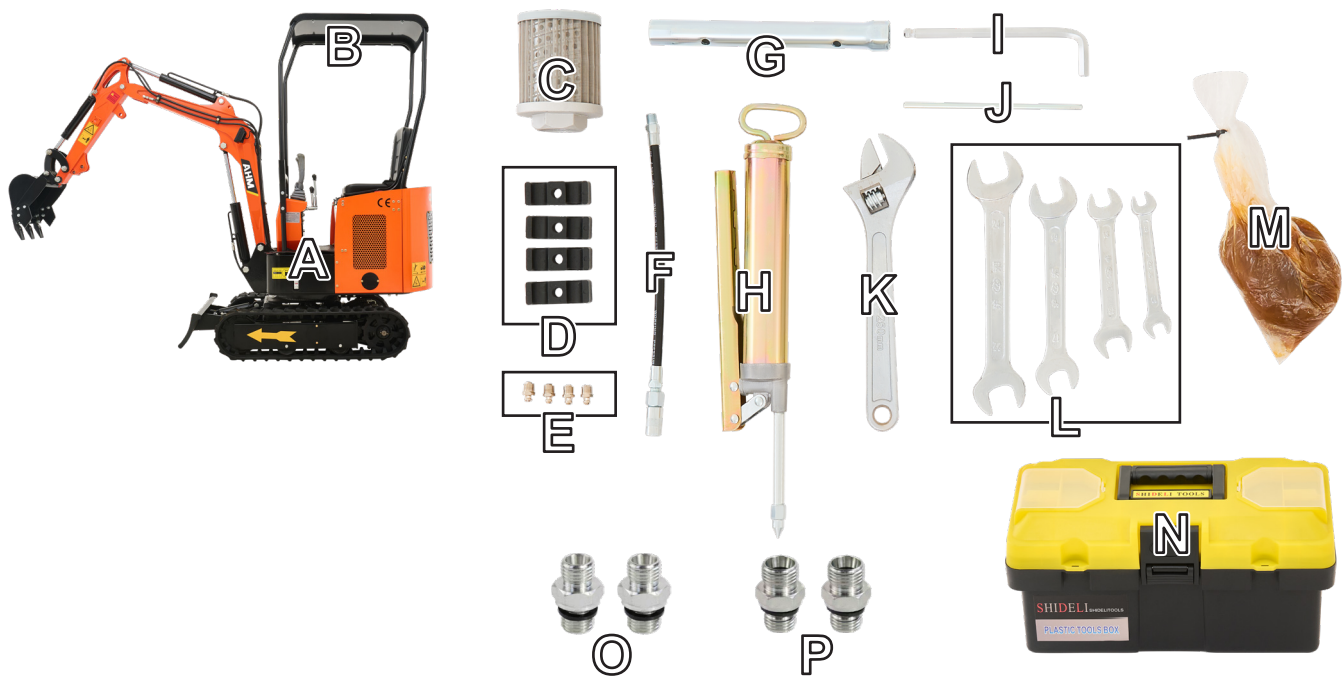

No.	Item	Qty.
A	Mini Excavator	1
B	Cab Roof	1
C	Hydraulic Oil-Pickup Filter Element	1
D	Pipe Clamps	4
E	Grease Fittings	4
F	Flexible Hose Nozzle	1
G	Socket	1
H	Grease Gun	1
I	Hex Wrench	1
J	Socket Lever	1
K	Adjustable Wrench	1
L	Wrenches of 22×24mm, 17×19 mm, 13×16 mm, and 8×10 mm	4
M	Lubricating Grease	1
N	Tool Box	1
O	M14 Male to M16 Male Thread Adapters	2
P	M14 Male to M14 Male Thread Adapters	2

6 Installation

6.1 Installing the Cab Roof

1. Use at least 3 people to unpack the package. Check that the excavator is intact and free of any damage.

The cab roof and its frame should arrive uninstalled.

2. Remove the bolts located around the four corners of the driver's seat.

There should be 2 on each of the front right and left corners and 4 on each rear left and right corners.

3. Have two people lift the cab roof and its frame to where it should be installed. Align the holes on the frame base with the ones on the excavator.
4. Tighten the bolts.

Warning

NEVER operate the excavator with the cab roof removed.



6.2 Changing the Attachment

1. Your excavator should arrive with the bucket uninstalled.

Warning

The bucket is fastened to the arm through two bolts and nuts. Installation and removal of the bolts require strength and care. Always wear protection and exercise care. Use at least two people to handle the bucket.

2. Ensure the machine is parked on level ground. Lower the bucket's flat surface onto the ground to prevent bucket movement.
3. Remove the two nuts at the upfront as shown. Remove the bolts and keep them where they won't be compromised by metal debris or sand grains.



4. Have two people carry the attachment to be installed and align it with the two holes on the arm.
5. Replace the bolts and tighten the nuts.

7 Operation

7.1 Starting the Engine

1. Circle the excavator to check for anomalies, inform the coworkers of the imminent task, and tell the signalman/flagman to stand by.
2. Enter the cab in the way depicted. Sit in the driver's seat, checking that there are no obstructions on the dashboard or around the joysticks. If you see any signs indicating the excavator is out of order, exit the cab.



3. Fasten the seat belt and buckle up. Check all control rods/joysticks are in the neutral position. If not, reset them to neutral.
4. Locate the red power switch on your left near the seat. Turn while pulling the switch in the direction indicated by the label around it.



Power Switch

5. Locate the throttle lever, which should look as shown. Hold its end, hold down the button located on top, and push the lever away from you.

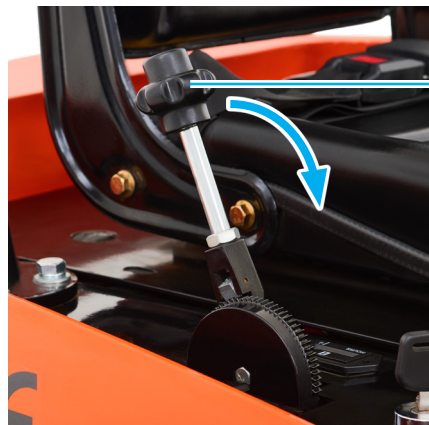

Throttle Lever

6. Insert the ignition key, turn it counterclockwise and hold for some time (for temperatures below 35°F/2°C, approximately 25 to 30 seconds; for temperatures 35°F/2°C or higher, approximately 10 to 15 seconds) to preheat the engine glow plugs, then turn the key clockwise to start the engine.



Ignition Key

7.2 Using the Headlights

Locate the headlights button. Turn it on and off to check that the headlights light up and shut off.

Warning

The headlights may not be bright enough for all working conditions. Use additional illumination when needed. Remember to turn off the lights when you turn off the engine.

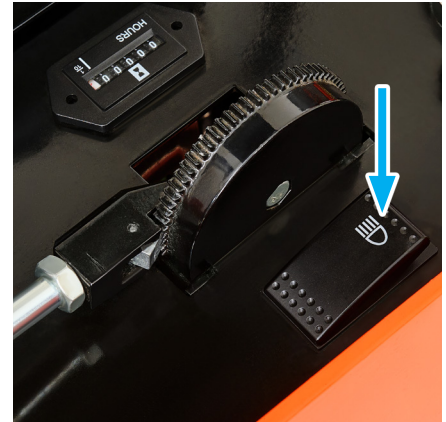

7.3 Using the Excavation Timer

Locate the excavation timer. It works automatically as soon as the power is turned on, recording the total working hours of the whole system.

Be aware that the timer is not resettable and will keep increasing.

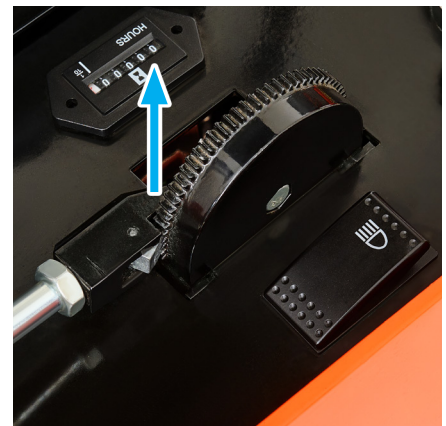

7.4 Forward & Backward Travel & Steering

1. Make sure that your excavator has started and warmed up as stated in §7.1 Starting the Engine on Page 27.

2. Use the two second-longest rods to control the travel.

- To move your excavator forward, push them together away from you.
- To move your excavator backward, pull them together towards you.
- To move only one of the tracks, push or pull either of the two travel rods.
- To turn left while traveling, push the right travel rod while releasing the left one.
- To turn right while traveling, push the left travel rod while releasing the right one.

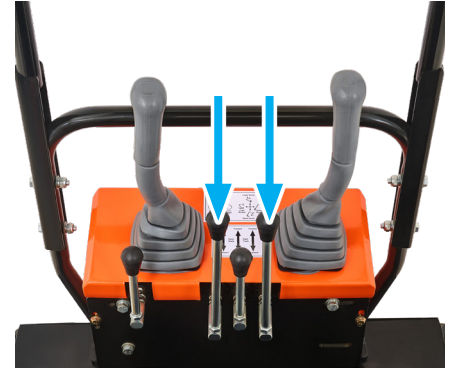

Warning

When the excavator is mobile, **NEVER** push one rod while pulling the other. This **WILL** topple the excavator.

3. Use the throttle lever to control the speed.

- To speed up the excavator, hold its end, hold down the button located on the top, and push it away from you.
- To slow down the excavator, hold its end, hold down the button located on the top, and pull it towards you.

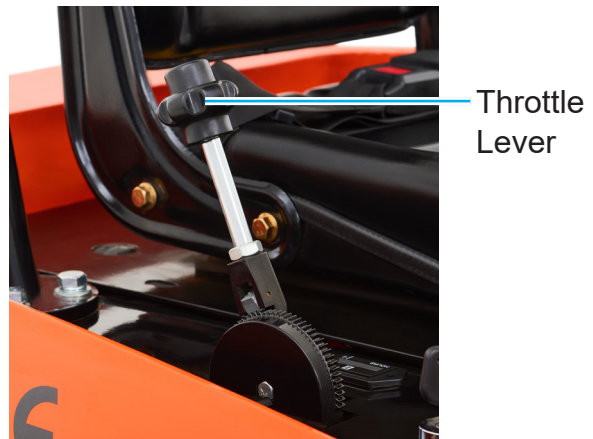

7.5 Basic Excavation

1. Make sure that your excavator has started and warmed up as stated in §7.1 Starting the Engine on Page 27.
2. Steer the excavator to where the digging is expected to be carried out.
3. Refer to the figure below for a basic understanding of the excavation control rods/joysticks.

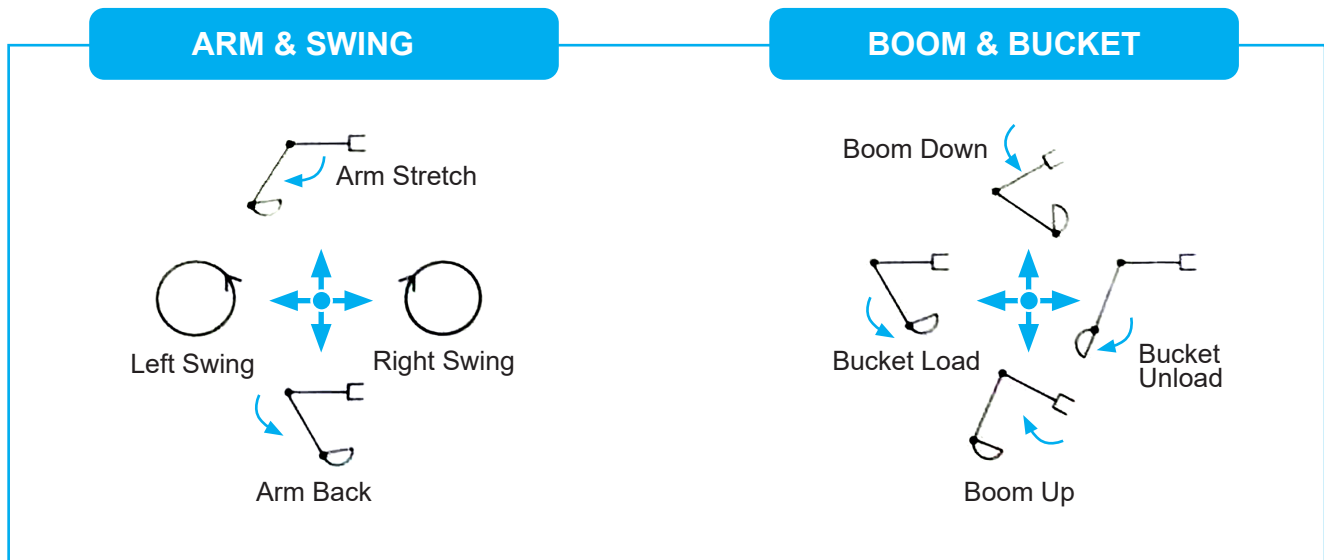

4. Start excavating with the two joysticks.

Left Joystick Right Joystick

The left joystick controls the arm and swing:

- To raise the arm (aka dipper, stick, or crowd), push it forward.
- To retract the arm, pull it toward you.
- To swing the cab left, push it to your left.
- To swing the cab right, push it to your right.

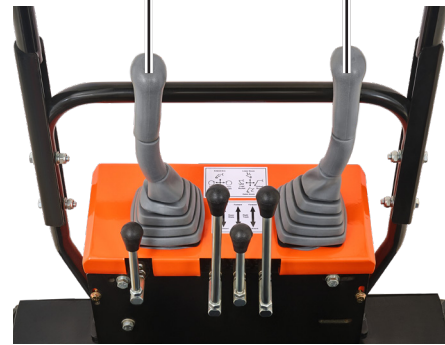

The right joystick controls the boom and bucket:

- To lower the boom, push it forward.
- To raise the boom, pull it toward you.
- To load the bucket, push it left.
- To unload the bucket, push it right.

⚠ Warning

- *For better results on hard ground, angle the arm cylinder roughly perpendicular to the arm and bucket 30° to the ground so that you exert the largest excavating force. For soft ground, angle the bucket 60° to the ground.*

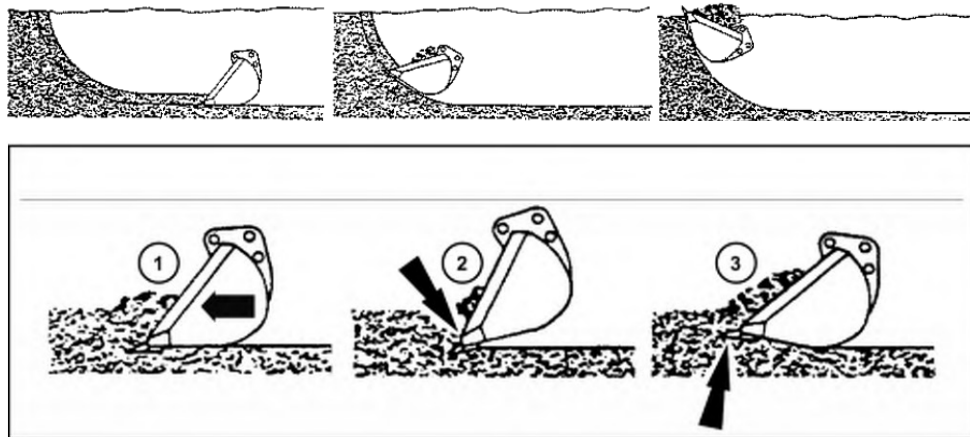

SMIL13CEX2694EB 3

1. Correct
2. Incorrect. The bucket will dig in and cause a stall.
3. Incorrect. The bucket is pushed upwards. This will also increase the cycle time.

- *Achieving a seamless mastery of excavation demands consistent practice, honed skills, and proficient handling of the excavator. Prior to actual operation, engage in practice sessions at an open area that is robust enough to support the excavator's movement safely and devoid of any onlookers. For optimal outcomes, consider seeking guidance from an experienced excavator owner or enrolling in professional training.*

7.6 Basic Bulldozing

Warning

ALWAYS make sure the rods are at the neutral before powering up the whole system.

1. Make sure that your excavator has started and warmed up as stated in **§7.1 Starting the Engine** on Page 27.
2. Steer the excavator to where the bulldozing is expected to be carried out.
3. Start bulldozing with the shortest rod in the middle.
 - To raise the dozer, pull it towards you.
 - To lower the dozer, push it away.



7.7 Leveling

1. Make sure that your excavator has started and warmed up as stated in **§7.1 Starting the Engine** on Page 27.
2. Steer the excavator to where the digging is expected to be carried out.
3. Position the bucket in proximity to the excavator.
4. Gradually push the soil from the side of the mound.
5. As the mound reduces in height, shift the topsoil from the peak.

If the load causes excessive strain on the machine, adjust by raising or lowering the bucket.

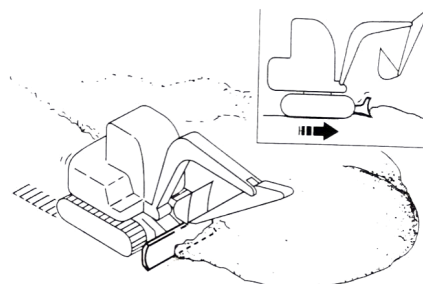

7.8 Transportation

Warning

- **DO NOT** employ the attachment for loading or unloading the excavator, as this could result in rolling or falling.
- Ensure the truck and loading surface are clean, devoid of oil, sand, ice, snow, or any foreign materials to prevent the excavator from sliding. Clear the tracks.

1. Select a sturdy, level ground area at a safe distance from the roadside.
2. Place a warning sign near the transportation area to alert passing pedestrians and vehicles.

3. Securely fasten two ramps with adequate strength and dimensions to the truck bed.

The incline angle must not exceed 15°. If the ramps are too steep, utilize a support pillar or block underneath them.

Make sure that the ramps are wide enough for full contact with both tracks.

Refer to the picture for the truck and ramp preparation.

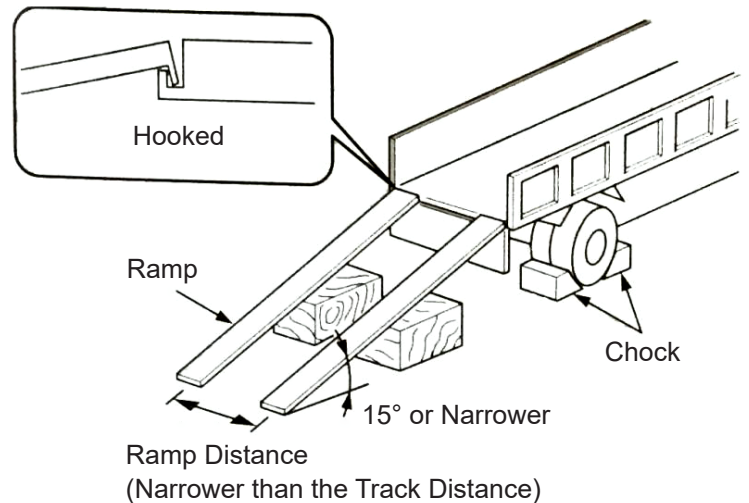

4. Steer the excavator to travel slowly onto the ramps, being sure the tracks are fully on the ramp.

Danger

DO NOT change direction when on the ramps. Travel slowly and steadily.

5. Stop when the whole excavator is inside the truck bed.
6. Cut the engine, and ensure all control rods/ joysticks are at neutral.
7. Remove the keys.
8. Use chocks to immobilize the tracks and prevent movement. Secure the machine to the truck using a cable or chain if possible.
9. Lock the trunk doors and lids if any.

8 Maintenance

Refer to the excavation timer located as shown. Maintain your excavator according to the schedules below.

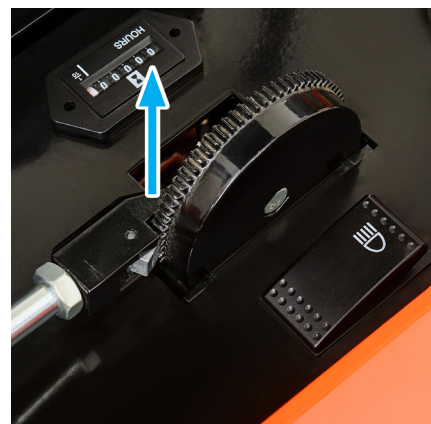

8.1 Checks before Maintenance

Always do the following before performing any maintenance to the machine to ensure your safety:

- Read and understand **Safety Information** on Pages **2–23** before proceeding with any inspection or maintenance procedures.
- Do not perform any maintenance unless authorized in this chapter for this machine.
- Avoid working on the machine while the engine is running unless you are required to do so in the procedure.

If the engine must remain running during a procedure, always have a person in the cab who can correctly operate the machine and is in clear contact with you at all times.

- Contact Customer Service if you are unable to perform the procedures listed in this manual or if additional procedures are required.
- Always use the proper tools when performing any maintenance procedures.

8.2 General Maintenance Schedule

No.	Item	Qty.	Interval (h)	
			10	50
1	Engine Oil Level	1	★	
2	Hydraulic Oil Level	1	★	
3	Fuel Level	1		★
4	Oil-Water Separator	1		★
5	Fuel Pipe Check	----	★	
6	Work Equipment Pivots	----	★	
7	Hydraulic Hose & Pipelines	----	★	
8	Bucket Teeth	4		★
9	Seat Belt	1	★	
10	Bolts and Nuts Torque	----		●

Note:
 ★ : Routine Maintenance Interval
 ● : Maintenance Prior to Initial Use

8.3 Greasing, Replacement & Periodical Check Schedule

No.	Item	Interval (h)							
		100	250	500	1000	1500	2000	2500	4000
1	Greasing of Swing Bearing		★						
2	Greasing of Swing Bearing Gears	★							
3	Changing Engine Oil	●	▲	★					
4	Changing Hydraulic Oil					△	★	△	
5	Changing Hydraulic Oil Suction Filter Elements				★				
6	Fuel Pipe Crack/Bent Check		★						
7	Changing of Oil-Water Separator			★					
8	Fuel Hose Leakage/Crack Check		★						
9	Fuel Hose Leakage/Crack Check		★						
10	Changing of Bucket								
11	Connection of Bucket								
12	Removal of the Traveling Handle								
13	Replacement of the Seat Belt								
14	Track Deflection Check			★					
15	Tensioner Maintenance			★			★		

Note:
 ★ : Routine maintenance interval
 ▲ : Maintenance interval of engine oil
 △ : In situations where crushing conditions are frequent, halve the replacement intervals for hydraulic oil and filters.
 ☆ : Under dusty environments, shorten the maintenance interval.

8.4 Work Equipment Pins Lubrication

Parts		Qty.	Interval (h)						
			50	100	250	500	1000	2000	2000
Pivots	Boom Base Pivot	10	★						
	Boom Base Cylinder Pivot								
	Bucket and Connecting Rod Pivots								
	Others	6	★						
Swing	Swing Bearing	2				★			
	Swing Bearing External Meshing Gear	1					★		

Note:

Using lithium grease is recommended.

★ : Routine Maintenance interval

8.4.1 Locations of Work Equipment Pins

- Pivots between the bucket and connecting rod
- Pivot at the base of the boom



- Pivots of the boom cylinder



- Others:
Pivot between boom and arm; pivots of arm cylinder; pivots of bucket cylinder.



8.4.2 Lubricating the Slew Bearing

1. Position the excavator on level ground.
2. Lower the bucket to the ground.
3. Allow the engine to idle at low speed for 5 minutes.
4. Switch the ignition **OFF** and remove the key.
5. While the upper structure remains stationary, apply grease to the two grease nozzles until the old grease overflows.

Warning

***DO NOT** over-grease, as it can damage the seal of the swing support, leading to grease leaks and the entry of dust, exacerbating wear and tear.*

6. Initiate the engine to raise the bucket clear of the ground. Rotate the cab by 45 degrees (1/8 circle).
7. Repeat the steps 2–6 until the bucket rotates a full circle.

8.4.3 Lubricating the Meshing Gear of Slew Bearing

1. Park the excavator on level ground.
2. Lower the bucket to the ground.
3. Allow the engine to idle at low speed for 5 minutes.
4. Switch the ignition **OFF** and remove the key.
5. Ensure the grease is stored free from contamination on top of the external meshing gear of the slewing bearing.

If necessary, add approximately 0.5 kg of grease. Any contaminated grease should be replaced with fresh grease.

***Note:** Lithium grease is recommended.*



8.5 Engine Maintenance

Refer to the engine's manual for engine maintenance.

8.6 Greasing, Replacement & Periodical Check Schedule

Item	Qty.	Interval (h)								
		10	50	100	250	500	1000	1500	2500	4000
Oil Level Check	1	★								
Drain Pipe Cleaning	1				★					
Replacing	16.5L/ 4.4 gal.								★	
Suction Filter Elements Replacing	1						★			
Hose& Pipeline Check					★					
				★						
Change the hose	39									★
<p>Note: ★ : Routine Maintenance Interval</p>										

8.7 Hydraulic System

8.7.1 Checking the Hydraulic Cylinders

Warning

- Hang a “**DO NOT OPERATE**” sign on the joystick to prevent accidental machine activation during inspection.
 - For your safety and a longer service life of the hydraulic cylinders, it is recommended that you have them checked and serviced by a certified mechanist.
1. Park the excavator on a level and stable surface, then lower the bucket to the ground and turn off the engine.
 2. Allow sufficient time for the hydraulic system to cool down completely to avoid exposure to hot and pressurized components.

Warning

The hydraulic system will remain hot after working. Wait for it to completely cool down before handling it.

3. Bleed air completely from the hydraulic oil reservoir.

4. Perform the following checks on the hydraulic cylinders.

- Inspect the hydraulic cylinders for any signs of leakage, such as oil spots, drips, or accumulated oil around seals and connections.
- Examine the cylinders' exterior surface for dents, scratches, or any damage that could affect its performance.
- Check the rod and piston for any signs of wear, corrosion, or scoring. Run your fingers along their surfaces to detect irregularities.
- Gently check the rod seals and wiper seals for cracks, tears, or deterioration.



5. If the cylinders require disassembly for a more thorough inspection, contact Customer Service.

6. Execute one of the following depending on your checking result:

- If everything is in order:
 - a. Reassemble any components that were disassembled.
 - b. Remove any safety measures.
 - c. Test the hydraulic cylinders' functionality through controlled movements.
- If you encounter any abnormal behavior or suspect an issue during testing:
 - a. Immediately turn off the engine.
 - b. Contact Customer Service.
 - c. Reassemble any components that were disassembled.

7. Keep a detailed record of the inspection, including findings and actions taken, for future reference and maintenance tracking.

8.7.2 Checking the Hydraulic Oil Level

Warning

NEVER start the engine with no hydraulic oil.

Check the hydraulic oil level after each use following the steps below.

1. Ensure the machine is parked on level ground.
2. Fully retract the arm cylinder and extend the bucket cylinder outward to position the machine.
3. Lower the bucket onto the ground.
4. Wait for the engine to idle at low speed for 5 minutes.
5. Turn off the engine and remove the ignition key.
6. Check the hydraulic oil level gauge.

The normal level should range between 1/2 and 2/3 of the tank. If the hydraulic oil falls below 1/2, refill it. For instructions, see **§8.7.3 Refilling the Hydraulic Oil** on Page 40.



8.7.3 Refilling the Hydraulic Oil

1. Carefully open the oil cap while releasing the pressure slowly.

Warning

The hydraulic oil tank is pressurized. Failure to do so may result in oil spraying out and causing potential hazards. **ALWAYS** exercise caution when working with pressurized systems.

2. Infuse the right type of hydraulic oil until 2/3 of the tank by checking the hydraulic oil level gauge.



3. Replace the cap.

8.7.4 Replacing the Hydraulic Oil Suction Filter Element

Warning

***DO NOT** proceed until the hydraulic oil cools down, as it may be very hot.*

1. Park the machine on a level surface, wait for the engine to idle at low speed for 5 minutes, turn off the engine, and remove the ignition key.
2. Locate the hydraulic oil cap. Clean the top of the hydraulic oil reservoir to prevent dirt from entering the system.
3. Carefully open the oil cap to release pressure.

Warning

*The hydraulic oil tank is pressurized. Failure to do so may result in oil spraying out and causing potential hazards. **ALWAYS** exercise caution when working with pressurized systems.*

4. Loosen and remove the hydraulic oil-pickup filter element cap.
5. Loosen and remove the drain plug at the bottom of the hydraulic oil tank to drain the oil.
6. Remove the hydraulic oil-pickup filter and the levers.
7. Thoroughly clean the filter and the inside of the hydraulic tank. Utilize a hydraulic oil-pickup pump to extract any remaining oil residue from the tank's bottom.
8. Position the filter and levers back, and attach the hydraulic oil-pickup filter element cap, tightening the bolts to 49 N·m.

Warning

Starting the engine without hydraulic oil may damage the hydraulic pump.

9. Clean and reinstall the drain plug at the tank's bottom.
10. Add oil. For instructions, see **§8.7.3 Refilling the Hydraulic Oil** on Page 40.
11. Replace and tighten the oil tank cap.

8.7.5 Checking Hoses & Pipelines

Danger

- *Any sprayed fluid can penetrate your skin, resulting in serious injury. Always use a paperboard to check for leakage. Furthermore, exercise extreme caution to keep your hands and body away from pressurized oil. In the event of an accident, seek immediate medical attention from a doctor experienced in treating trauma. Any fluid that penetrates the skin must be removed within a few hours to prevent complications like gangrene.*
- *Leaked hydraulic oil and lubricant may pose a fire hazard or cause personal injury.*

1. Park the excavator on level ground.
2. Lower the bucket onto the ground.
3. Set all control rods to neutral, shut off the engine, and remove the ignition key.
4. Wait until the engine and the hydraulic system cool down completely.
5. Check the whole machine for any missing parts, loose pipe clamps, twisted hoses, pipelines, or hoses rubbing against each other.
6. Thoroughly tighten, repair, or replace any loose, damaged, or missing pipe clamps, hoses, pipes, oil coolers, and flange bolts.

 **Warning**

***DO NOT** bend or subject any pressure pipelines to impacts. **NEVER** install bent or damaged hoses or pipelines.*

8.8 Checking the Battery

- For a longer battery life, turn off the headlights when not needed.
- For a longer battery life, the single ignition time should not exceed 10 seconds, and there should be a minimum interval of 60 seconds between two ignitions.

If the machine fails to ignite three times in a row, stop igniting and proceed with troubleshooting.

- If you find it hard to start the engine, replace the battery with an identical one.

8.9 Checking the Bucket Teeth

Check if the bucket teeth are worn or loosened daily. Replace them with a new bucket if they have become shorter than 5.2 inch (130 mm).

 **Warning**

Exercise extreme care when changing the teeth. Wear goggles or safety protections.

8.10 Checking the Bolts and Nuts Tightening Torque

Check the torques of bolts and nuts at the initial 50 hrs. or prior to initial use and then every 250 h. Tighten them to the set torque if needed. Replace the damaged with identical ones. For required torques, see the table below.

Warning

ONLY use a torque wrench to check the torques of bolts and nuts.

Metric Bolts and Nuts			
Thread Dimensions	Standard Torque (N·m)	Thread Dimensions	Standard Torque (N·m)
M6	12±3	M14	160±30
M8	28±7	M16	240±40
M10	55±10	M20	460±60
M12	100±20	M30	1600±200
Main Components Torques (N·m)			
Thread Dimensions		Recommended Torque	
M16 Bolts Fixing the Traveling Motor		252±39.2	
M16 Bolts Fixing the Sprocket		252±39.2	
M20 Bolts Fixing the Swing Bearing		570±60	

8.11 Miscellaneous Checking Schedule

Parts	Quantity	Interval (h)								
		10	50	100	250	500	1000	2000	4000	
Bucket Teeth Check		★								
Changing the Bucket	—	If needed								
Adjusting the Bucket Connecting Rod	1	If needed								
Replacing Traveling Lever	2	If needed								
Checking and Replacing the Fuse	1	★	Every 3 years							
Checking the Track for Deflection	2					★				
Maintaining the Tensioner	2						★			
Checking the Fuel Injection Timing	—	If needed								
Measuring the Engine Compression Pressure	—						■			
Checking the Starter & the A/C Generator	—						■			
Checking the Bolts and Nuts Torque	—		◆		★					

Note:

- ★ : Maintenance interval under normal conditions
- ◆ : Maintenance needed at the first inspection
- : Contact Customer Service.

8.12 Checks after Maintenance

Always do the following after performing any maintenance to the machine:

- Ensure all steps listed in this manual have been followed.
- If necessary, have a coworker inspect your work for correct and proper completion.
- Check for leaks in the system you have maintained.
- Be sure no abnormal sounds are coming from the engine or hydraulic system.
- Check for any loose or abnormal movement in the system you have maintained.
- Check for any overheating in the system you have maintained.

After performing maintenance or repairs to the machine, always take time to inventory your tools, parts used, and nuts and bolts to be sure none of these items were left on or inside the machine.

Contact Us

Thank you for choosing our products! If you have any questions or comments, contact us at support@ahmcorp.com and we'll resolve your issue ASAP!

For a .pdf copy of the latest version of these instructions, use the appropriate app on your smartphone to scan the QR code to the right.

