

Electric Bicycle User Manual



Read Carefully Before Use
Keep for Future Reference

Disclaimer

Read this disclaimer completely and carefully before proceeding with the rest of the manual content.

1. **As-Is**

This Viribus product is sold 'as is' and without any express or implied warranties, including but not limited to the implied warranties of merchantability and fitness for a particular purpose.

2. **Product Modifications**

Any modifications or alterations to Viribus products void any warranties and may result in damage or injury. Viribus shall not be liable for any damages resulting from such modifications or alterations.

3. **Compliance with Laws**

Customers shall be liable for ensuring that the use of Viribus products complies with all applicable laws and regulations in their respective jurisdictions. Viribus assumes no responsibility for any violations of laws or regulations resulting from the use of Viribus products.

4. **Correct Use**

Always use Viribus products only as directed in the accompanying manuals. Failure to follow instructions may result in injury or damage.

Always ensure the assembly, installation, operation, maintenance, or repair of Viribus products is carried out by a competent person.

Always make maintenance regularly throughout Viribus products' lifecycles; you have the liability to keep the products operating as intended.

Always wear appropriate protective gear.

5. **Third-Party Products**

Viribus shall not be liable for any damages or losses resulting from the use of third-party products in conjunction with Viribus products. Customers shall refer to the third-party's guidelines or/and warranties (if any) for any third-party products used.

6. **Limitation of Liability**

Viribus shall not be liable for any direct, indirect, punitive, incidental, special, or consequential damages to property or life, whatsoever arising out of or connected with the use or misuse of Viribus products. In no event shall Viribus's liability exceed the value of the products sold.

This disclaimer states the entire obligation of Viribus with respect to Viribus products. If any part of this disclaimer is determined to be void, invalid, unenforceable, or illegal, including but not limited to the warranty disclaimers, liability disclaimers, and liability limitations set forth above, the invalid or unenforceable provision will be deemed superseded by a valid and enforceable provision that most closely matches the intent of the original provision and the remainder of the agreement shall remain in full force and effect.

Contents

Safety Information	1
Specifications	2
Product Diagram	2
Package List	4
Assembly	5
Installing the Handlebars.....	5
Installing the Front Wheel	6
Installing the Front Brake Caliper.....	7
Installing the Pedals	8
Installing the Rear Fender and Saddle.....	9
Installing the Front Fender and Light	9
Inflating the Tires.....	10
Installing the Battery.....	10
Operation	11
Battery.....	11
Activating and Deactivating the Display Panel.....	12
Manual Control.....	13
Pedal Assist Control	13
Throttle Control	14
Adjustment	14
Maintenance	17
Troubleshooting	17
General Instructions	17
Error Codes.....	19
Disposal	20

Safety Information

Warning

- Install and adjust this bicycle **ONLY** in accordance with these instructions. Read them completely prior to installation and use. Contact customer service if any point is unclear. Provide this manual to anyone who will use this bicycle and provide it with this bicycle if it is ever given or sold to a third party. Failure to do so may lead to serious property damage and severe personal injury, possibly including death.
- **ALWAYS** obey all applicable local and national laws and regulations while riding. Do not ride this bicycle in any area or at any speed prohibited to electric bicycles. Always wear your helmet and other required protective gear. Always maintain your reflectors and other required safety equipment. Note that any illegal delimiting voids all warranties stated or implied.
- **ALWAYS** check whether the brakes function well **BEFORE** riding. Even when power is cut to the motor, the inertia of the bike will often require active braking power.
- **ALWAYS** ensure all fasteners and components are intact and securely tightened before and after every use.
- **DO NOT** ride this bicycle if any part is damaged or shows any sign of malfunction. Repair or replace worn and broken components before further use. Never replace any parts with non-identical ones.
- **DO NOT** allow children or persons unfamiliar with this bicycle or these instructions to operate it. Do not ride it while you are tired or under the influence of medication.
- **DO NOT** wear loose footwear or clothing that may become caught in the wheels or any other moving parts.
- Pay attention to your remaining power before setting out and during use. Recharge your battery as needed to ensure it never runs out of power at a moment where you are taken by surprise.
- It is recommended that you not ride your bike fast when getting started. This can be ensured by setting the bike's maximum speed limit low until you are fully familiar with your new electric bike and its controls.
- **ALWAYS** be alert for people, animals, or any obstacles that may appear in front of you while riding your bicycle. Be aware that pedestrians and drivers may not expect the speed or responsiveness of your bike. Adjust your behavior accordingly. It is advisable to install warning devices to draw their attention, but always be ready to turn safely out of their way if needed. Do not focus on the LCD display panel for extended periods of time while riding.
- **NEVER** ride at a speed where your stopping distance exceeds your visibility. We do not recommend that you ride your bicycle at night or in an environment with poor visibility. If you have an emergency that makes it necessary to do so, keep your light on and limit your speed appropriately.
- **NEVER** use the throttle or pedal assist system in any situation, road condition, or terrain where doing so might impair your control of your bicycle.
- **NEVER** adjust the 03, 06, 07, 13, 14, or 15 parameters in the display menus. Adjustment of these parameters should only be made when using your display panel with other motorized wheels of differing voltage, diameter, or magnetic arrangement. In any other case, any adjustment of these parameters should be undone **IMMEDIATELY**. Restore the original settings before any further use of the bicycle.
- **DO NOT** get the batteries, the charger, or its power cord wet or operate them with wet hands or in highly humid environments. If they accidentally become damp or wet, wait for them to completely dry before any further use. If the interior of any battery becomes wet, replace it.
- Disconnect the 48V battery from this bicycle before any cleaning, servicing, and storage.
- **NEVER** place any battery near heat sources or explosive or flammable gases. Never expose them to radiation or excessive pressure. Only charge the 48V battery in locations with an ambient temperature between 32° and 110°F (0–45°C).
- **NEVER** modify any battery or power cord. Only use the provided charger with this bicycle.
- If any battery is ever damaged, avoid all contact with it or any leaking fluid. Remove contaminated clothing and flush with copious amounts of water if contact accidentally occurs with the skin. If contact accidentally occurs with the eyes, **IMMEDIATELY** flush them with copious amounts of water for at least 15 minutes while seeking medical attention.

Specifications

Motor Power		350 W
Wheel Diameter		26 in. ("06"=26) 66 cm
Magnet Arrangement	Speed Sensor	1 Alnico Magnet ("07"=1)
	Pedal Assist	5 Alnico Magnets ("13"=5)
Battery	Type	48V Rechargeable Lithium ("03"=48)
	Waterproof Rating	IP65
Control Hardware	Current Limit	15A ("14"=15)
	Undervoltage Lockout Threshold	39V ("15"=39)
Max. Speed		20 mph* 32 km/h*
Est. Operational Range		20 mi.** 32 km**
Operational Temp. Range		-4 to 145°F -20 to 65°C
Charging Temp. Range		32 to 110°F 0 to 45°C

* Based on unloaded wheel rotation at full power without friction with software limitations. True speed will vary according to variables such as battery strength and load but should remain within ± 1 mph of the displayed speed.

** Based on a 165 lb. or 75 kg load at full power and at full legal speed on actual roads.

Product Diagram

Bicycle



Handlebars

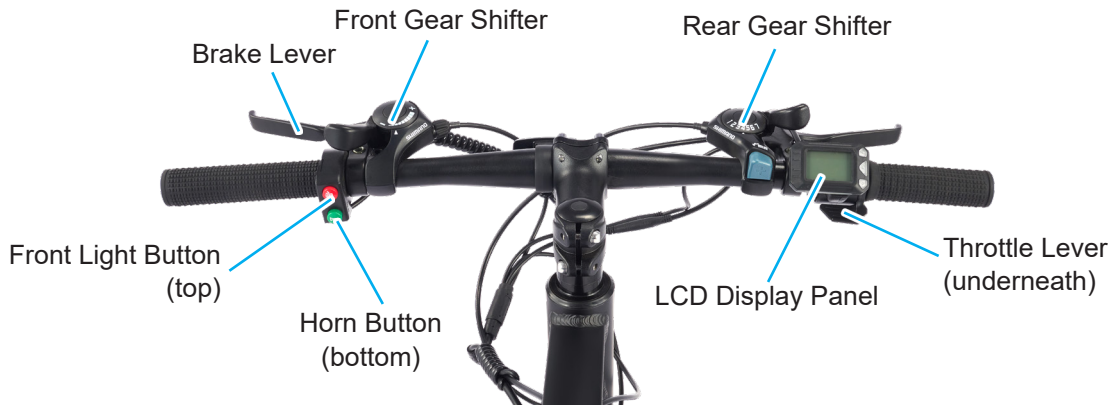

Display Panel



Buttons

- ▲: Increases the motor speed level or toggles values up when pressed.
- ⏻: Toggles the variable display when pressed. Turns the display panel on and off when held.
- ▼: Decreases the motor speed level, turns off the motor, or toggles values down when pressed.

Display

The top left corner displays when backend settings are being adjusted (SET), when the front light is on (💡), or when various errors occur: motor errors (⚙️), brake errors (🚫), throttle errors (🛑), and control hardware errors (🏠). Icons are also displayed when the backend settings have been adjusted to use a pedal start for throttle control (🚲) or to change the wheel diameter size (🛞).

The battery display shows your remaining battery power level.

The number on the top right is the current speed in mph or km/h.

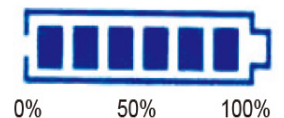

The number on the bottom left is the current throttle or pedal assist level.

The number on the bottom right is a variable display that may show your battery's voltage (VOL), your current trip distance (DIS), your total distance traveled (ODO), the current motor speed (RPM), or the various parameter menus and settings.

Package List

Item	Name	Qty.
A	Main Frame with Motorized Rear Wheel, Brake Disc, Chain, & Derailleur	1
B	Handlebars with LCD Display Panel	1
C	Front Wheel with Brake Disc	1
D	Pedals	2
E	Saddle	1
F	Front Light	1
G	Battery	1
H	Charger	1
I	Power Cord	1
J	M4 Hex Wrench	1
K	M5 Hex Wrench	1
L	8×10mm Wrench	1
M	13×15mm Wrench	1
N	Phillips Screwdriver	1
O	Front Fender	1
P	Rear Fender	1
Q	Front Brake Caliper	1

Assembly

To see these instructions in video form, search the **Viribus Bikes** channel at [youtube.com](https://www.youtube.com).

Installing the Handlebars

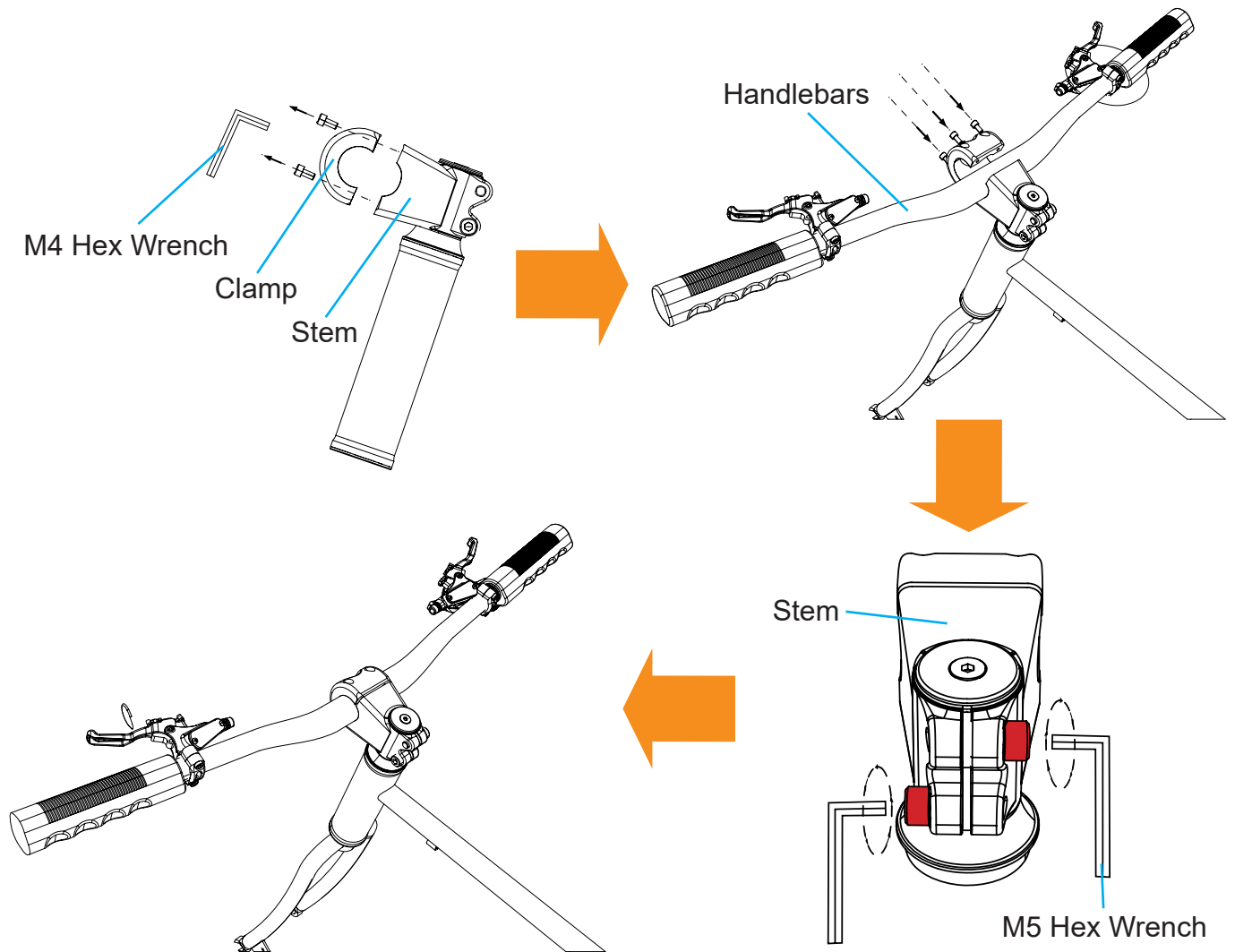

1. Place the main frame with the preinstalled rear wheel vertically on firm level ground. For best results, secure them with a bike stand or similar device (not included).
2. Rotate the handlebar stem to allow its clamp to face forward.
3. Remove the 4 bolts from the handlebar clamp using the M4 hex wrench and then remove the clamp. Place them nearby.
4. Fit the handlebars onto the stem, replacing its clamp.
5. Replace the bolts onto the clamp, tightening them to lock the handlebars in place.
6. Loosen the 2 bolts on the left and right sides of the handlebar stem using the M5 hex wrench.
7. Rotate the handlebars until they are perpendicular to and their stem is well aligned with the top and down tubes.
8. Retighten these bolts to lock the stem in place.

Installing the Front Wheel

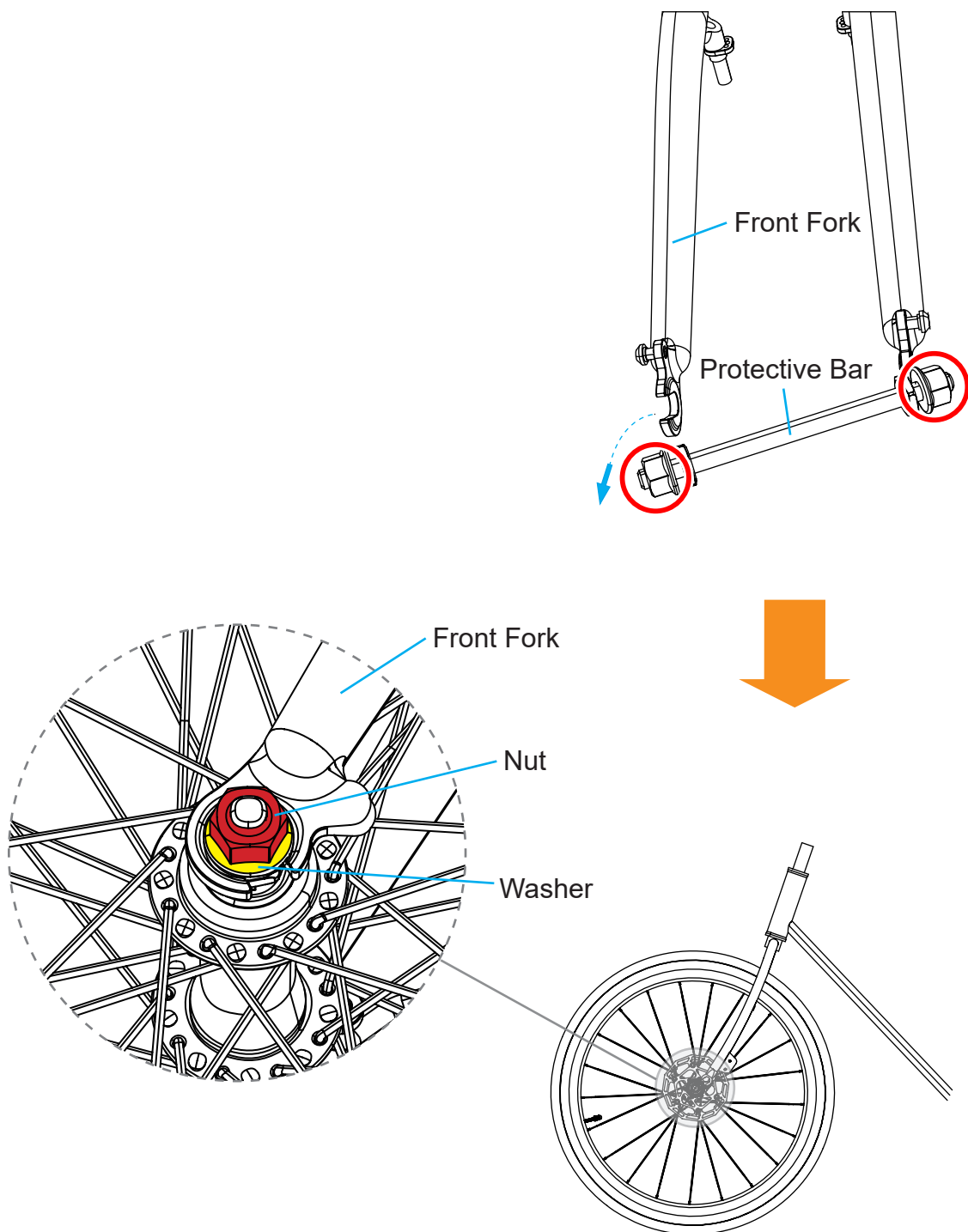

1. Loosen the nuts on the front fork's tips using the 13×15mm wrench and disconnect the protective bar from the fork.
2. Remove the 2 sets of nuts and washers from both sides of the front wheel axle. Place them nearby.
3. Fit the front wheel into the front fork, placing the preinstalled front brake disc at the left side and allowing its axle to be snugly held.
4. Replace the washers and nuts, tightening the nuts with the 13×15mm wrench.

Installing the Front Brake Caliper

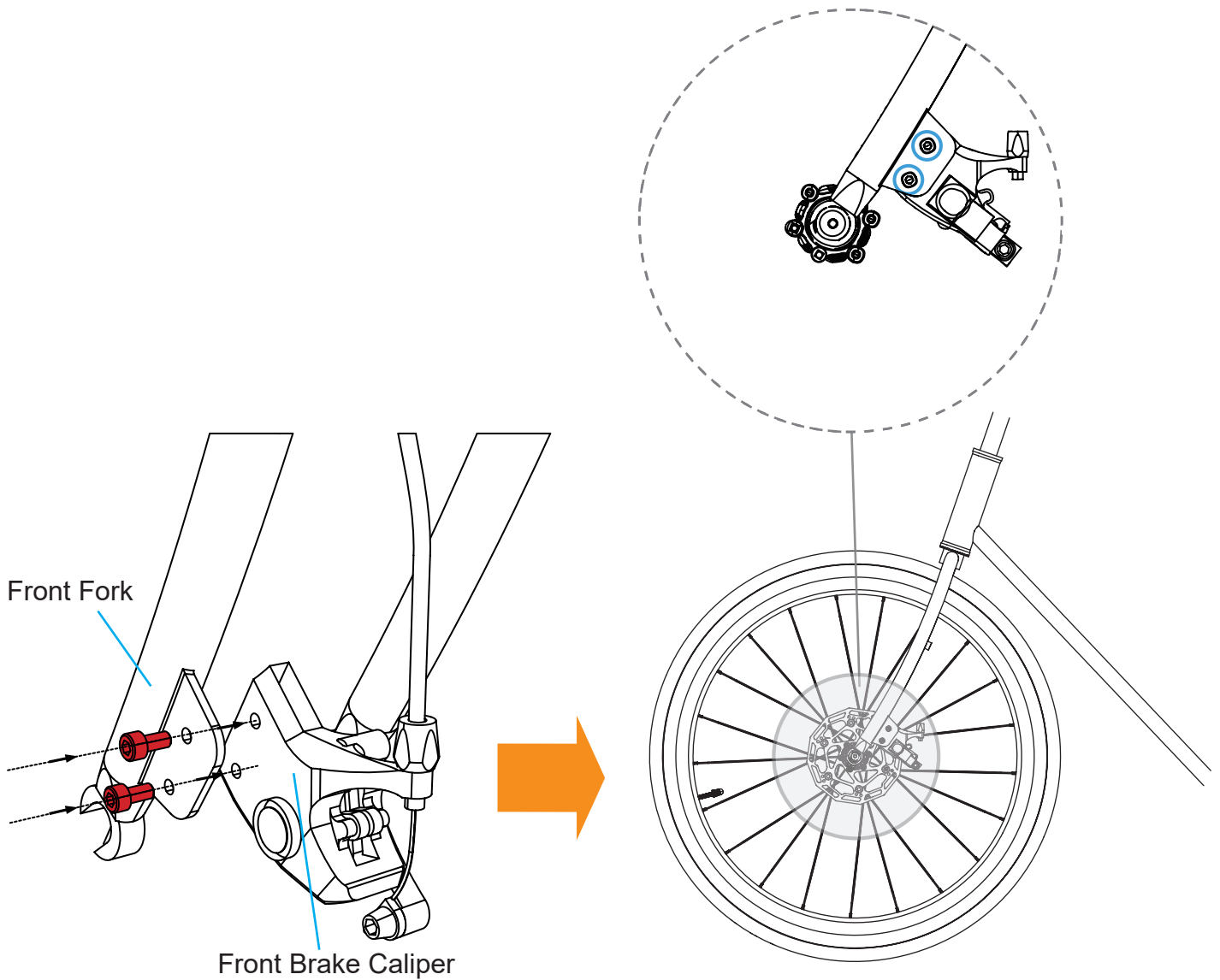

1. Remove the two bolts from the front brake caliper using the M5 hex wrench. Place them nearby.
2. Fit the caliper onto its holder on the left side of the front fork.
3. Replace and tighten the removed bolts to secure the caliper in place.
4. Test that the brake levers and brakes work smoothly and firmly before continuing.

Installing the Pedals

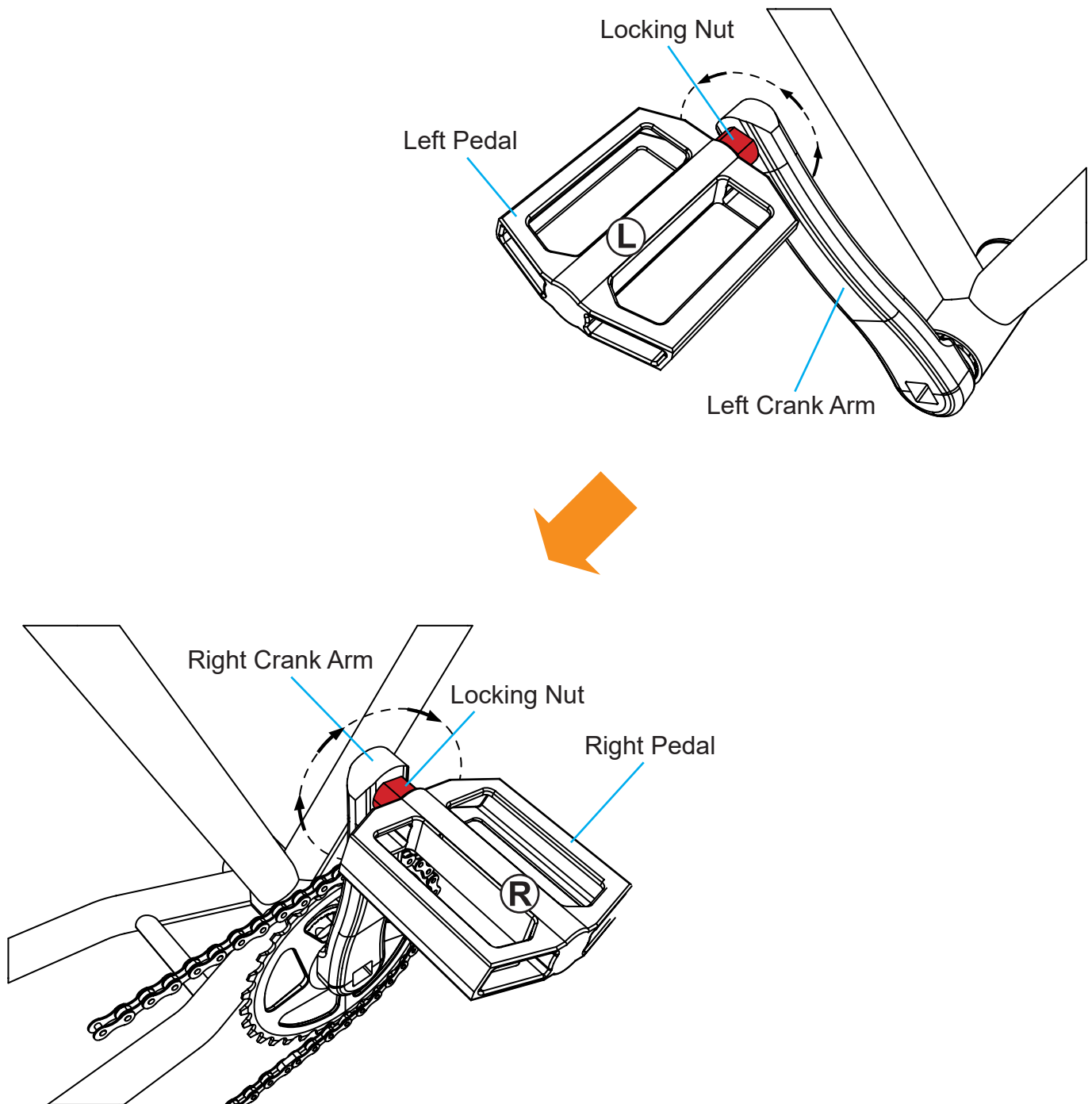

1. Identify the separate pedals, which **ARE** different and should **NOT** be mixed up. The left pedal is marked with an **L** and the right with an **R**.

Note: *Screwing a pedal at the wrong side may cause damage to its threads.*

2. Attach each pedal to the appropriate crank arm, screwing each into place.
3. Tighten the pedals' locking nuts with the 13×15mm wrench.
4. Test that the pedals are securely fastened and rotate freely.

Installing the Rear Fender and Saddle



1. Attach the rear fender to the post of the saddle, slide it into place, and tighten its locking bolt with the Phillips screwdriver.
2. Loosen the clamp on the top of the seat tube by rotating its lever.
3. Insert the saddle post into the tube until your preferred height is reached.
4. Retighten the clamp using its lever.
5. Check that the saddle is secure. If needed, loosen the clamp, tighten its adjustment nut on the other side, and retighten the clamp.
6. To adjust the saddle forward or backward, loosen the two nuts underneath the saddle using the 13×15mm wrench, slide the saddle on its support frame until your desired position is reached, and retighten the nuts. Confirm they hold tight and the saddle does not show any wobble.

Installing the Front Fender and Light

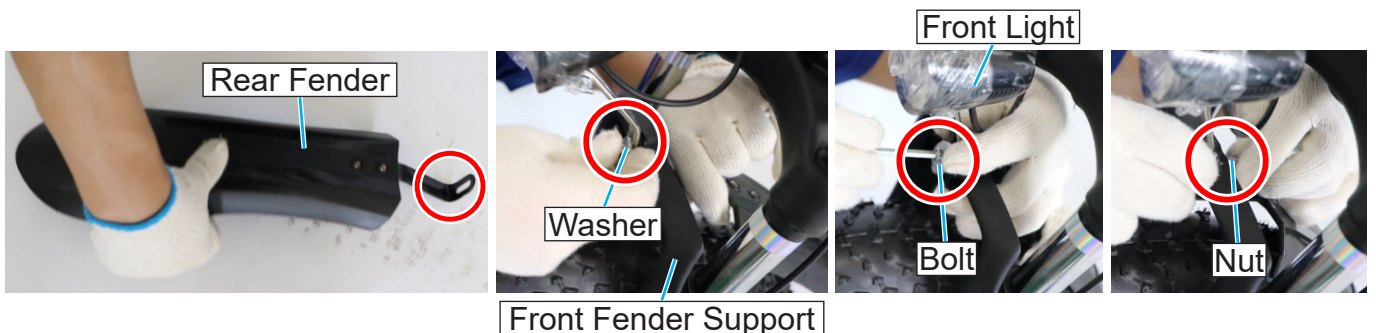

1. Remove the nut, bolt, and washer from the front fender support above the front wheel.
2. Fit the front light and front fender onto the support as shown.
3. Replace the washer, bolt, and nut, tightening the bolt with the M5 hex wrench and the nut with the 8×10mm wrench simultaneously.

Inflating the Tires



1. Remove the valve cap on a wheel.
2. Connect the valve to an appropriate pump.
3. Inflate the tire until it feels firm. For best results, stop inflation when the pressure reaches 50 psi (3.4 bars).
4. Disconnect your pump from the wheel, replacing the valve cap immediately.
5. Inflate the other tire following the same steps.

Installing the Battery

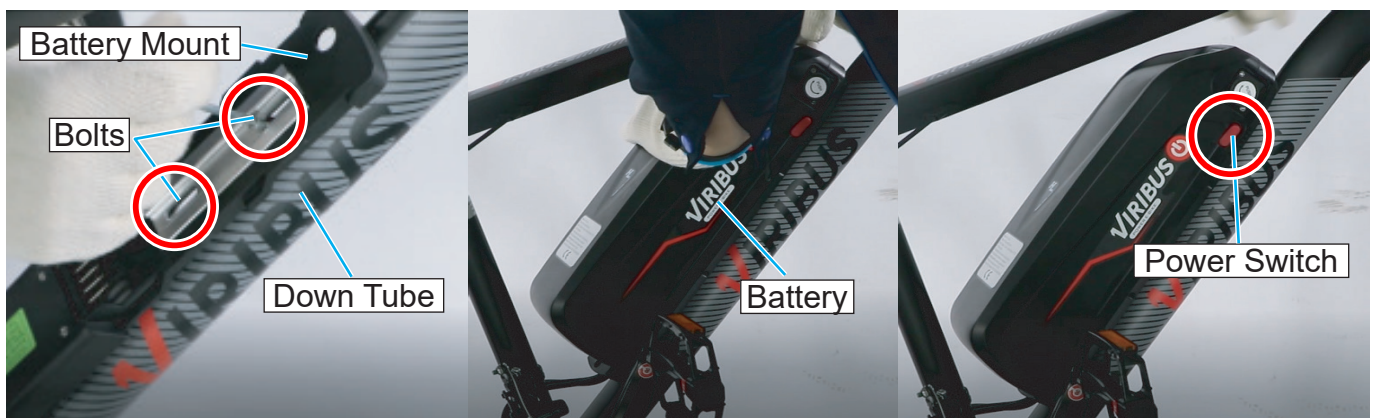

1. Remove the bolts from the down tube and place them nearby.
2. Slide the battery mount away from the battery and fit the mount onto the down tube.
3. Align the slots on the battery mount with those on the down tube, securing it in place by replacing the bolts and tightening them with the M4 hex wrench.
4. Insert the attached key beside the battery into the keyhole on the battery.
5. Turn the key counterclockwise to unlock the battery.
6. Fit the battery onto its mount, pressing until it clicks into place.
7. Turn the key completely clockwise to lock the battery in place.
8. To activate or deactivate the LCD display panel and the motor, flip the battery's power switch to **I** or **O**.

Operation

Battery

Caution

DO NOT allow the battery to ever drain completely, which may reduce its lifespan and even make it hard to reactivate.

Battery Capacity Levels

In addition to the handlebar display, your bicycle's current power level can be checked on the battery itself.

To check the battery's current power level:

1. Flip the battery's power switch to I.



Power Switch

2. Press the power display button to see how many of the battery's indicator lights turn on.

4 lights indicate a full battery, while 1 light indicates a weak one.

Power Indicator Lights



Power Display Button

Charging

When you find that recharging is necessary:

1. Remove the cover from the charging port beside the battery's power switch.
2. Connect the provided charger to its power cord and the charging port.



Charging Port

Power Switch

3. Connect the power cord to a stable and compatible power supply.
4. Turn on the battery using its power switch and periodically check the state of the battery with the power display button.

There is no need to fully recharge the battery. Either 3 or 4 lights should provide strong and responsive service.

5. When finished, disconnect the power cord from power and then the charger from the battery. Remember to properly insert the battery into the holder if you have taken it out.

⚠ Warning

DO NOT leave the battery connected to power once it is already fully charged.

Overcharging can cause the battery to overheat, which may result in decreased performance or **EVEN** fires or explosions.

Activating and Deactivating the Display Panel

1. Ensuring that the battery is on, hold  until the display panel activates.

Note: **ALWAYS** perform this before using the throttle or pedal/push assist control.

2. To deactivate the panel, hold  again until its screen shuts down.



⚠ Warning

Simply deactivating the battery can also directly turn off the display panel. **HOWEVER**, this abrupt cut of power is **NOT** recommended and risks damaging the bicycle's components and circuits.

Manual Control

You can leave the display panel or battery turned off to ride your bike normally with 21-speed gearing. You can also ride normally with the electronic display turned on by pressing ▼ until the motor is put into neutral ("0").

The Shimano thumb shifters use levers and buttons to control the 3 front rings on the left in combination with the 7 rear cogs on the right. On the left side, the larger bars closer to + represent the largest ring and the smaller bars closer to – the smallest ring. Push the friction shift lever away with your thumb to downshift sharply and pull it towards you with your finger(s) to upshift sharply. On the right side, the larger numbers represent the smallest sprockets. Press the + button at the base of the shifter to upshift and push the lever beside the shifter away to downshift.

Warning

Be sure your bicycle's crank is turning while using either shifter to adjust the chain.

If you press ▲ while the display panel is on, the bike will activate PAS control at Level 1. If you press the throttle lever while the display panel is on, the bike will activate throttle control and accelerate to its top speed.

Pedal Assist Control

The pedal assist system (PAS) requires you to continue using the pedals to keep the motor active but provides additional speed and strength as you ride. By default, the PAS has three levels and a 20 mph or 32 km/h top speed. This top speed can be adjusted. If it is, the lower levels will run at 60% and 80% of the new top speed.

Level	0	1	2	3
Speed	—	12 mph	16 mph	20 mph
	—	20 km/h	26 km/h	32 km/h
	0%	60%	80%	100%

The PAS can also be adjusted to use five levels instead, providing additional lower speeds.

Level	0	1	2	3	4	5
Speed	—	8 mph	11 mph	13 mph	16 mph	20 mph
	—	13 km/h	18 km/h	22 km/h	26 km/h	32 km/h
	0%	40%	55%	67%	80%	100%

By default, the PAS is activated at Level 1 as soon as the battery and display panel are on. The bike will accelerate to the speed of current level—8 mph or 13 km/h at Level 1—as soon as the pedals fully turn two times. Press ▲ to go up one level. Press ▼ to go down one level.

The PAS automatically pauses and the motor temporarily shifts to neutral

- If you stop pedaling,
- If you press either brake lever, or
- If your bike accelerates on a slope to a speed faster than your current power level.

The PAS reactivates at its current level once both brakes are released, your speed is at or below the current target, and you resume pedaling. Going from Level 1 to 0 also disables the PAS and puts the motor in neutral until ▲ is pressed, restarting PAS at Level 1.

If you press the throttle lever while PAS is active, the bike will activate throttle control and accelerate to its top speed. If you turn off the display or battery while PAS is active, the motor will stop and the bike will only operate manually.

Throttle Control

This electric bike can work as a single-speed scooter using the throttle lever on the right handlebar. By default, throttle control operates at the bike's top speed—20 mph or 32 km/h—and is available whenever the battery and display panel are on. Press the throttle lever, stop pedaling the bike, and your bike will continue along at the set speed. Note that some jurisdictions require throttle control to be disabled on electric bikes. (See Parameter 10 in the Adjustment section below.)

Warning

The bicycle will not exceed its set speed on flat pavement but may do so on slopes.

Throttle control automatically pauses and the motor temporarily shifts to neutral if you press either brake lever or accelerate beyond the current top speed. The motor will resume working once both brakes are released and your speed is at or below the top speed.

If you begin pedaling while throttle control is active, the bike will activate PAS control. If you turn off the display or battery while throttle control is active, the motor will stop and the bike will only operate manually.

Adjustment

To adjust the bike's parameter:

1. Hold ⏻ until the display panel activates.
2. Hold ▲ and ▼ simultaneously to enter the adjustment menus.
You will automatically start with parameter 01 (Display Brightness).
3. For each parameter, use ▲ and ▼ to change the settings and ⏻ to save your changes and move to the next parameter.
4. Wait for the display panel to automatically reset to leave the adjustment menus, saving all current changes.

 **Warning**

***DO NOT** adjust parameters 03, 06, 07, 13, 14, or 15 while using this display panel with this bike. Parameters 03, 14, and 15 concern details of the electricity coming from the main battery. Parameter 06 allows adjustment of the compatible wheel diameter. Parameters 07 and 13 concern the arrangement of magnets within your motorized wheel. These can be used to modify the display to work with other motorized bicycles but changing any of these values during use with this bicycle **WILL** cause it to perform abnormally, malfunction, and/or break. If such adjustment happens accidentally, stop the bike **IMMEDIATELY** and **IMMEDIATELY** correct the settings.*

Parameter	Value	Parameter	Value
03	48	13	5
06	26	14	15
07	1	15	39

01 Display Brightness

Press ▲ and ▼ to adjust the brightness of the display panel. Using the minimum setting that is clearly visible affects your battery life a very little bit but more importantly allows your eyes to go between the road and the display with less readjustment in low light conditions. Setting 1 is dim, 2 is medium, and 3 is bright.

02 Measurement Units

By default, speeds and distances are displayed in US/English customary units (miles and mph). Press ▲ and ▼ to toggle between it and metric (km and km/h). Setting 0 is metric and 1 is US.

03 Battery Voltage

Never adjust this value. If it is ever changed by accident, stop the bike and reset it to 48 before continuing on your way.

04 Timed Shutoff

By default, your display panel and motor remain in standby mode indefinitely when you park your bike (Setting 0). To activate an automatic shutoff once the bike has stopped moving for 1 minute, press ▲ to raise this parameter to 1. Press ▲ and ▼ to adjust the number of minutes before the display shuts down from 1 to 60 or return this setting to 0 to disable the shutoff altogether.

05 Power Levels

By default, your PAS operates with 3 power levels (60/80/100%). Press ▲ and ▼ to toggle between this and 5 levels (40/55/67/80/100%). Setting 0 activates 3 levels of operation and 1 activates 5 levels.

06 Wheel Diameter

Never adjust this value. If it is ever changed by accident, stop the bike and reset it to 26 before continuing on your way.

07 Speed Sensor(s)

Never adjust this value. If it is ever changed by accident, stop the bike and reset it to 1 before continuing on your way.

08 Top Speed

By default, your motor has a top speed of 20 mph or 32 km/h. While in 3-level mode (see “05”

above), press ▲ and ▼ to adjust this value. While using US customary units (see “02” above), the speeds will vary as shown:

Value	≤14	15	16	17	18	19	≥20
Level 1	8 mph	9 mph	10 mph	10 mph	11 mph	11 mph	12 mph
Level 2	11 mph	12 mph	13 mph	14 mph	14 mph	15 mph	16 mph
Level 3	14 mph	15 mph	16 mph	17 mph	18 mph	19 mph	20 mph

While using metric units (see “02” above), the speeds will vary as shown:

Value	≤22	23	24	25	26	27	28	29	30	31	≥32
Level 1	13 km/h	14 km/h	14 km/h	15 km/h	16 km/h	16 km/h	17 km/h	17 km/h	18 km/h	19 km/h	20 km/h
Level 2	18 km/h	18 km/h	19 km/h	20 km/h	21 km/h	22 km/h	22 km/h	23 km/h	24 km/h	25 km/h	26 km/h
Level 3	22 km/h	23 km/h	24 km/h	25 km/h	26 km/h	27 km/h	28 km/h	29 km/h	30 km/h	31 km/h	32 km/h

09 Throttle Start

By default, the throttle lever instantly activates the bike's single-speed cruise control. Press ▲ and ▼ to toggle between this and requiring two full rotations of the pedal before throttle control activates. Setting 0 activates instant throttle response and 1 activates a two-rotation start.

10 PAS or Throttle Disablement

By default, your bike offers manual, the PAS, and throttle control as explained above. Press ▲ and ▼ to toggle among this, enabling the PAS only, and enabling throttle control only. Setting 0 disables throttle control. Setting 1 disables PAS control. Setting 2 reactivates both. (To disable both PAS and throttle control, simply leave your battery off or turn off the display panel while riding.)

11 PAS Sensitivity

By default, your bike activates its pedal assist system when you turn the pedals two full rotations while the battery and display panel are both on. Press ▲ and ▼ to adjust how quickly you need to turn the pedals to activate the PAS. Lower values require less pedaling and higher values more.

12 PAS Acceleration

By default, your bike ramps up the pedal assist speed for its current level smoothly and evenly. Press ▲ and ▼ to fine tune this acceleration to suit your riding style. Lower values accelerate more gradually and higher values more quickly.

13 Magnetic Arrangement

Never adjust this value. If it is ever changed by accident, stop the bike and reset it to 5 before continuing on your way.

14 Maximum Current

Never adjust this value. If it is ever changed by accident, stop the bike and reset it to 15 before continuing on your way.

15 Minimum Voltage

Never adjust this value. If it is ever changed by accident, stop the bike and reset it to 39 before continuing on your way.

16 Odometer Reset

Hold ▲ while this parameter is active to reset your bike's total distance traveled to 0.

Maintenance

- Disconnect the power after each use and prior to any cleaning or other maintenance.
- Check the parts of the bicycle for any looseness, wear, or damage after use. Tighten, repair, or replace any problematic parts before further use.
- The exterior of the bicycle can be cleaned with a soft damp cloth. Do not use abrasive or caustic chemicals.
- Lubricate the chain and any moving part using a standard bike lubricant as needed.
- If the bicycle will not be used for an extended period of time, store in a cool dry place inaccessible to children.





Troubleshooting

General Instructions

Problems	Causes	Solutions
Slipping chain	<ul style="list-style-type: none"> • Excessively worn/chipped front cog or rear cassette • Chain worn/stretched • Stiff link in the chain • Non-compatible chain 	<ul style="list-style-type: none"> • Replace the chain front cog, rear cassette, and chain. • Replace the chain. • Lubricate or replace the link. • Seek advice at a bicycle shop.
Constant clicking noises when pedaling	<ul style="list-style-type: none"> • Stiff chain link • Loose pedal axle/bearing • Loose bottom bracket axle/bearings • Bent bottom bracket or pedal axle • Loose crankset 	<ul style="list-style-type: none"> • Lubricate the chain/adjust the chain link. • Adjust the bearings/axle nut. • Adjust the bottom bracket. • Replace the bottom bracket axle or pedals. • Tighten the crank bolts.
Grinding noise when pedaling	<ul style="list-style-type: none"> • Pedal bearings are too tight. • The bottom bracket bearings are too tight. 	<ul style="list-style-type: none"> • Adjust the bearings. • Adjust the bearings.
Brakes not working effectively	<ul style="list-style-type: none"> • Brake pads worn down • Brake pads greasy, wet, or dirty • Brake cables are binding/stretched/damaged • Brake levers are binding • Brakes out of adjustment 	<ul style="list-style-type: none"> • Replace the brake pads. • Clean the pads. • Clean/adjust/replace the cables. • Adjust the brake levers. • Center the brakes.
When applying the brakes, they squeal/squeak	<ul style="list-style-type: none"> • Brake pads worn down • Brake pads toe-in incorrect • Brake pads/rim dirty or wet • Brake arms loose 	<ul style="list-style-type: none"> • Replace the pads. • Correct pads toe-in. • Clean the pads and rim. • Tighten the mounting bolts.

Problems	Causes	Solutions
Knocking or shuddering when applying brakes	<ul style="list-style-type: none"> • Bulge in the rim or rim out of true • Brake mounting bolts loose • Brakes out of adjustment • Fork loose in the head tube 	<ul style="list-style-type: none"> • True wheel or take to a bicycle shop for repair. • Tighten the bolts. • Center the brakes and/or adjust the brake pads toe-in. • Tighten the headset.
The power indicator lights not turning on when pressing the power display button on the battery	<ul style="list-style-type: none"> • Battery drained. • Battery's power switch is not flipped to I. 	<ul style="list-style-type: none"> • Recharge the battery. • Flip the power switch to I.
Unable to remove battery from bicycle	<ul style="list-style-type: none"> • Key not in its unlock position 	<ul style="list-style-type: none"> • Push in the key, turning it counterclockwise to unlock the battery.
Charging Failure	<ul style="list-style-type: none"> • Charger not correctly connected • Battery in an over-low-power state • Charger/ power cord/battery broken 	<ul style="list-style-type: none"> • Ensure the charger is correctly connected to a working power source. • Revive the battery in an over-low-power state. <ol style="list-style-type: none"> 1. Reinstall the battery onto your bicycle. 2. Raise the motorized wheel. 3. Run the motor using the throttle handle for a while. 4. Stop the motor, disconnect the battery, and restart charging. • Replace the charger, its power cord, or the battery with a new identical one.
Display Panel Failure	<ul style="list-style-type: none"> • Battery not seated in place • Battery's power switch is not flipped to I. • Mechanical cause 	<ul style="list-style-type: none"> • Seat the battery in place. • Flip the power switch to I. • Have trained technicians inspect, retighten, repair, or replace the related wiring and/or problematic parts.

Error Codes

Icon	Problem	Usual Solutions
	Motor Failure	<ul style="list-style-type: none"> Retighten the appropriate wire connection(s). Replace the problematic part with a new identical one.
	Control Hardware Failure	
	Throttle Failure	<ul style="list-style-type: none"> This icon is displayed when throttle control is disabled. (See Parameter 10 in the Adjustment section above.) This is normal and indicates everything else is working correctly. If this icon is displayed when throttle control is not disabled, something has malfunctioned. Check the wiring and condition of the throttle and motor. Repair or replace any problematic parts.
	Brake Lever Failure	<ul style="list-style-type: none"> This icon is displayed every time the brake levers disconnect the motorized wheel from its power. This is normal and indicates everything is working correctly. If this icon is displayed when the brake levers are not engaged, something has malfunctioned. Check the wiring and condition of the brake levers, lines, and motorized wheel. Replace any problematic parts with a new identical one.

Disposal

Electrical products should not be disposed of with household products. In the EU and UK, according to the European Directive 2012/19/EU for the disposal of electrical and electronic equipment and its implementation in national laws, used electrical products must be collected separately and disposed of at the collection points provided for this purpose. Locations in Australia, Canada, and the United States may have similar regulations. Contact your local authorities or dealer for disposal and recycling advice.

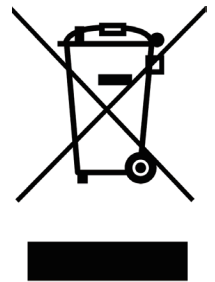

Contact Us

Thank you for choosing our products! If you have any questions or comments, contact us at support@viribusbikes.com and we'll resolve your issue ASAP!

For a .pdf copy of the latest version of these instructions, use the appropriate app on your smartphone to scan the QR code to the right.

