



# MINI CRAWLER EXCAVATOR USER MANUAL



Read Carefully Before Use  
Keep for Future Reference

# Preface

Congratulations on your new mini excavator!

Welcome to the user manual for the mini excavator. We are thrilled to provide you with a comprehensive guide on operating and maintaining this powerful and versatile machine. Whether you're a seasoned professional or a newcomer to the world of construction and excavation, this manual is designed to be your reliable companion throughout your journey with the mini excavator.

Within these pages, you'll find detailed instructions, safety guidelines, and valuable tips to ensure that you operate the mini excavator efficiently, effectively, and most importantly, safely. We aim to empower you with the knowledge and confidence needed to harness the full potential of this equipment while prioritizing the well-being of both yourself and those around you. From assembling and starting up the mini excavator to executing complex digging and lifting tasks, we've covered every aspect to make your experience seamless. Additionally, you'll discover insights into routine maintenance procedures that will keep your mini excavator in prime condition, prolonging its lifespan and optimizing its performance.

Safety is paramount, and we emphasize the importance of adhering to the provided guidelines. This manual clearly explains safety protocols, operational best practices, and hazard mitigation techniques. By prioritizing safety, you're protecting yourself and creating a secure environment for your team and job site.

Remember, this manual is not just a technical document; it's a guide tailored to your needs. We encourage you to familiarize yourself with its content, explore its sections, and refer back to it whenever needed. Our commitment is to empower you with the knowledge necessary to make the most of your mini excavator, elevating your capabilities and contributing to successful projects.

Thank you for choosing our mini excavator. Your journey starts here, and we're excited to embark on it together. Let's dig in!

# Contents

<b>About the Machine .....</b>	<b>1</b>
Work Equipment Compatibility .....	1
<b>Safety Information .....</b>	<b>2</b>
General Safety.....	2
Operation Temperature Safety .....	2
Personal Safety .....	3
Operation Safety.....	4
General Operation Safety.....	4
Travel Safety.....	6
Load & Unload Safety.....	11
Excavation Safety.....	12
Hoisting Safety .....	13
Hydraulic Cylinders Safety .....	14
Water Safety.....	16
Mud Escaping.....	17
<i>One-Track Entrapment .....</i>	<i>17</i>
<i>Two-Track Entrapment .....</i>	<i>17</i>
Parking Safety .....	17
Worksite Safety .....	18
Oil Safety .....	20
Maintenance Safety.....	20
<b>Specifications .....</b>	<b>24</b>
<b>Assembly.....</b>	<b>25</b>
Installing the Cover.....	25
Changing the Work Equipment.....	25
<b>Operation.....</b>	<b>26</b>
Starting the Engine .....	26
Headlights.....	27

Excavation Timer.....	27
Forward & Backward Travel & Steering.....	28
Basic Excavation.....	29
Basic Bulldozing.....	30
Leveling.....	30
Transportation.....	31
<b>Maintenance.....</b>	<b>32</b>
General Maintenance Schedule.....	32
Greasing, Replacement & Periodical Check Schedule.....	33
Work Equipment Pins Lubrication.....	33
Locations of Work Equipment Pins.....	34
Lubricating the Slew Bearing.....	35
Lubricating the Meshing Gear of Slew Bearing.....	35
Engine Maintenance.....	35
Hydraulic Systems Maintenance.....	36
Checking the Hydraulic Cylinder.....	36
Daily Check of Hydraulic Oil Level.....	37
Replacing the Hydraulic Oil Suction Filter Element.....	38
Checking Hoses & Pipelines.....	38
Checking the Battery.....	39
Checking the Bucket Teeth.....	39
Changing the Work Equipment.....	39
Checking the Bolts and Nuts Tightening Torque.....	40
Miscellaneous Checking Schedule.....	40

# About the Machine

This excavator is versatile and applicable to farming, landscaping, ditching and fertilization in gardens, vegetable greenhouses, agricultural transformation, indoor demolition, small earthwork, civil engineering, road recovery, basement and indoor construction, concrete breaking, cable burying, water supply line laying, garden cultivation, desilting, and the like.

Your excavator is designed for lasting performance, featuring either a robust KUBOTA diesel engine or a reliable BRIGGS & STRATTON gasoline engine. With these trusted engines, you can expect durability and consistent power for your operations.

Moreover, the versatility of this excavator extends to its compatibility with a wide range of work equipment. Whether you require a quick hitch, log grapple, ripper, leveling bucket, auger, or narrow bucket, this excavator can serve your needs.

## Work Equipment Compatibility

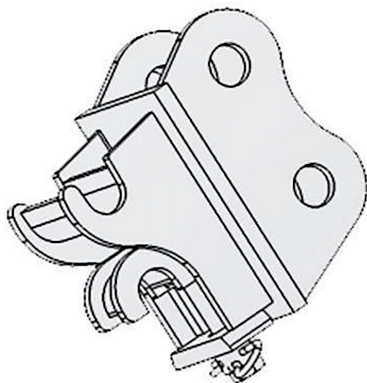

Quick Hitch

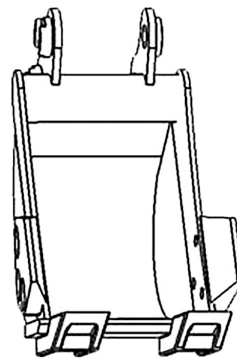

Narrow Bucket

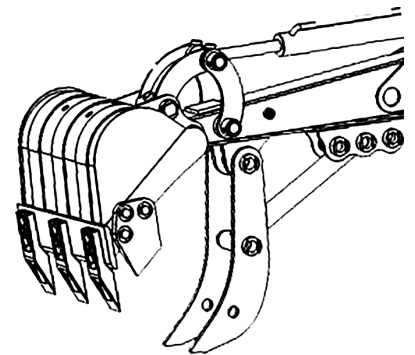

Mechanical Thumb

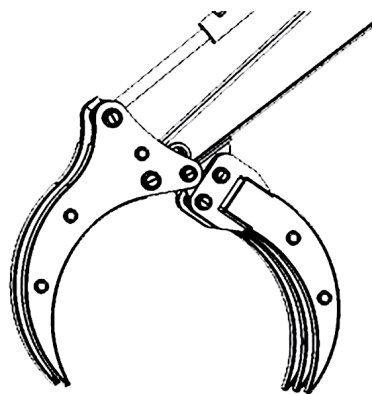

Log Grapple

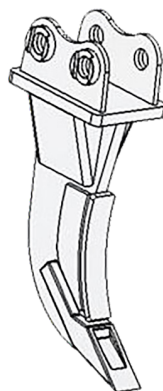

Ripper

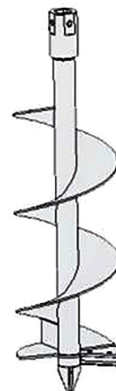

Auger

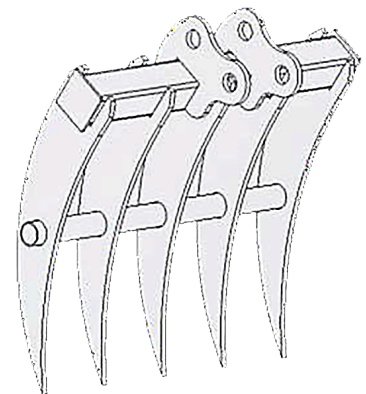

Rake

# Safety Information

## General Safety

- **ALWAYS** follow federal, state and local laws, codes and regulations concerning the use of construction machinery.
- Read this manual before actually operating the excavator. Familiarize yourself with the instructions that provide crucial information about the specific model's controls, maintenance requirements, and safety precautions.
- **ONLY** guarantee or allow persons with holistic knowledge of the safe operation of an excavator to operate, inspect or maintain the excavator.
- Strictly follow all the precautions and safety information as mentioned in this manual when operating, inspecting and maintaining the excavator.
- **DO NOT** operate, inspect or maintain the excavator when alcohol, drugs, medicines, fatigue, or lack of sleep impair your faculties or judgment. **NEVER** allow any persons under such conditions to operate, inspect or maintain this heavy machinery.
- Operating heavy equipment requires your full attention. Avoid distractions and remain focused on the task at hand.
- **IMMEDIATELY** cease use and contact Customer Service if the excavator shows any signs of anomalies or malfunctions, say noise, vibration, odor, leakage, error alarm, etc. **NEVER** attempt to resume using the excavator if the issues remain unsolved.

## Operation Temperature Safety

### Warning!

- For proper functioning and expected performance of the excavator, **DO NOT** operate the excavator if the ambient temperature is higher than 113 °F (45°C) or lower than 5°F (–15°C).  
Operating the machine under an ambient temperature higher than 113 °F (45°C) can cause the engine to overheat, compromise your energy efficiency, and shorten the hydraulic system's service life.
- If the excavator works at an ambient temperature below 5°F (–15°C), the gaskets and other rubber parts may freeze or harden, causing early and excessive wear to the excavator.
- Under cold temperatures, the excavator may take some time to warm up before working normally. After starting the engine, let it run idle for a couple of minutes and allow all systems a few minutes to get ready.
- **ONLY** use the rubber track at temperatures between –13 to 131°F (–25 to 55°C)
- If the excavator must work in such conditions, please consult Customer Service.

## Personal Safety

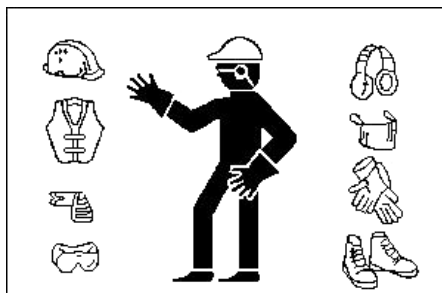

### Warning!

- **DO NOT** wear loose clothes or accessories that may get caught in the moving parts of your excavator in operation. Wear clothes that are oil-repellent. Replace them if grim or grease start to build up. Fabrics coated or soaked with grim can burn in proximity to heated machinery.
- **ALWAYS** use personal protective equipment (PPE) suitable to your task. Always wear ANSI and OSHA-approved eye, breathing, and hand protection while using this product. Nonslip and steel-toe footwear is also highly recommended. Other equipment such as ear, head, and body protection may also be necessary depending on your work, work environment, and other equipment.
- **ALWAYS** keep a fire extinguisher and first-aid kit in an easily accessible place.

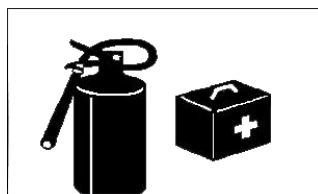

- Familiarize yourself with the protocols for using the first-aid kit and operating the fire extinguisher. Ensure that you provide training to other individuals who will be operating the excavator. This ensures that everyone is prepared to handle potential emergencies effectively.
- Display the contact details of the nearest Emergency Room (ER) prominently in the operator's area. Make sure that all personnel operating the excavator are well-informed about this information.
- Do not operate with the cover of the cab removed. Ensure the protective barriers, guards, screens, or covers are properly installed and secured before operating the excavator. Do not remove any safety devices except when inspecting and servicing the excavator. Always check that the safety devices are in good condition before operating.

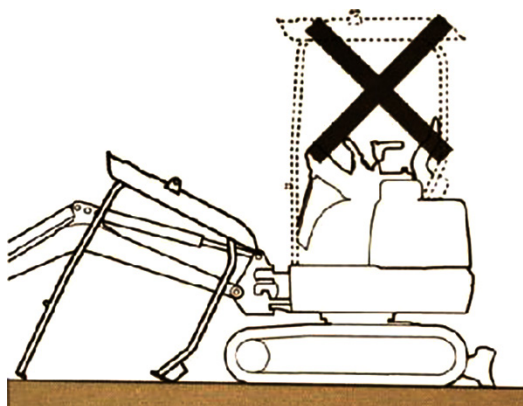

# Operation Safety

## Warning!

### General Operation Safety

- Due to the nature of construction work, using a signalman or flagman is necessary. Always ensure that you and any person involved fully understand the gestures and signals used by your signalman or flagman. If such a communication fails at any time, use an intercom communication.



- Prior to commencing any operations, run a comprehensive drill rehearsal to ensure that every participant comprehends, can effectively respond to, and proficiently practice both the designated signals and emergency protocols.
- Clean the soles of your shoes of any dirt, grease, or gravel on your soles before going into the cab. Operating the excavator pedal with dirt and grease on the soles may result in uncontrollable throttle or accidental falling from the cab.
- **NEVER** place any plastic or glass bottle in the cab, which could catch fire.
- **ALWAYS** lower your working device to the ground and shut the engine down before leaving the driver's seat. Store the key(s) in a designated place that is inaccessible to unauthorized use.

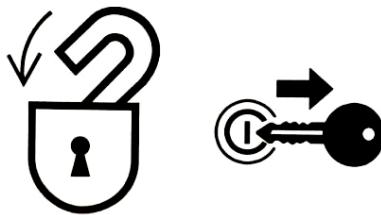

- **ALWAYS** check that the control rod/joystick is in neutral before starting or stopping the engine.
- Do not enter or exit the excavator by jumping. **ALWAYS** mount the excavator as depicted. **NEVER** attempt to get on and off a moving excavator. **NEVER** use the control rod/joystick as a handle.
- If the excavator must work in such conditions, please consult Customer Service.





- **NEVER** carry any persons with the excavator.



- **ALWAYS** circle the excavator to check for anomalies before entering the cab and operating.
- **ONLY** start the excavator when no one is within its operation radiuses.
- **NEVER** start the engine if you see a “**DO NOT OPERATE**” warning label or similar signs in the driver’s cab, the control rod, or the start switch.
- **NEVER** move the bracket over any person. Debris falling off could cause serious injuries or even death.

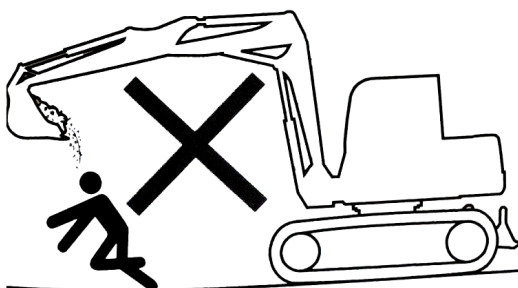

- **ALWAYS** visually check that the dozer is in front of the driver's seat before operating. If the dozer is at the rear of the driver's seat, the controls for turning and traveling will operate in reverse, contrary to the intended direction for the excavator's movement.

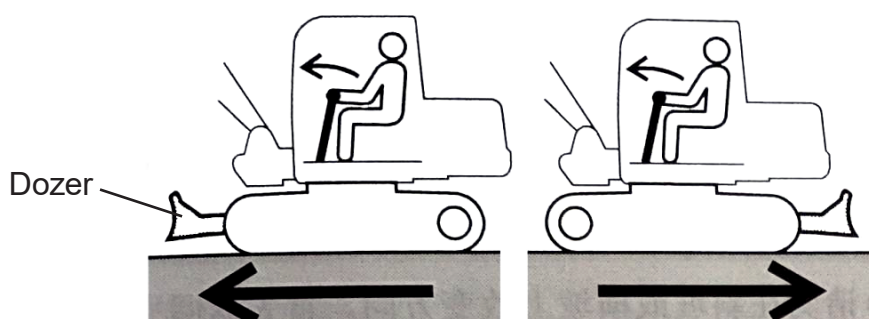

- **DO NOT** operate on soft or damp soil ground, on which this excavator may tilt or fall over. **DO NOT** operate on unstable ground. If the ground vibrates or shakes as you drive over, cease driving and exit the excavator immediately.

## Safety Information

- This excavator is designed for digging, bulldozing, and ditching. It has no compatible apparatus for hoisting. Consult a professional before operating this excavator for that purpose.

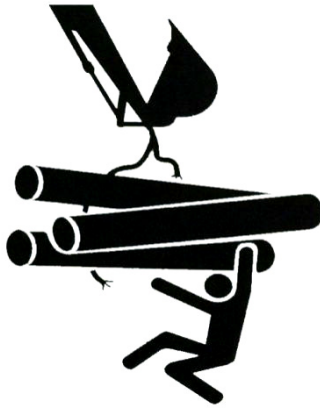

- **ALWAYS** know the locations of obstacles such as ditches, utility lines (like gas, power, and water), and things that might fall (like trees, overhead wires, or stones on a cliff).

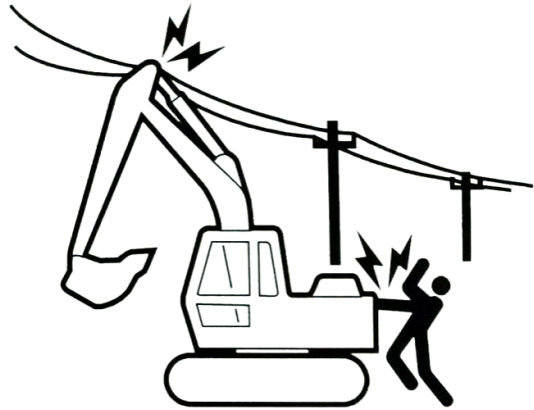

## Travel Safety

- **ALWAYS** check with the signalman or flag man that no person is standing within the operating radius of the excavator.

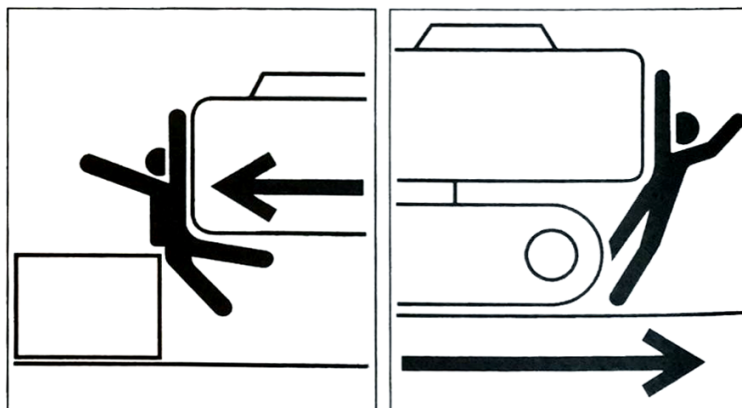

- **ALWAYS** confirm that there is no obstruction before the dozer that may topple the excavator while traveling. Raise the dozer and bucket as shown above the ground by 30 cm to 40 cm, depending on the specific terrain.

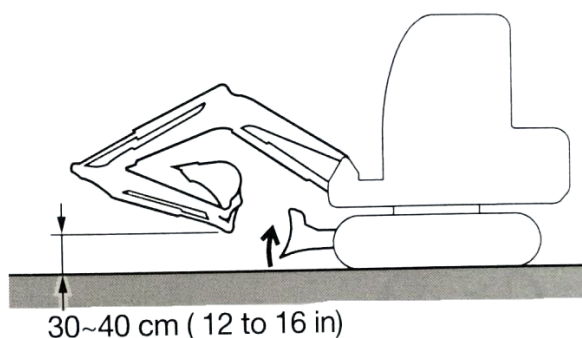

- **AVOID** traveling as shown below. Lower the dozer closer to the ground and travel slowly if you must. **DO NOT** attempt to climb obstacles that will tilt the excavator to an angle of 10° or higher.

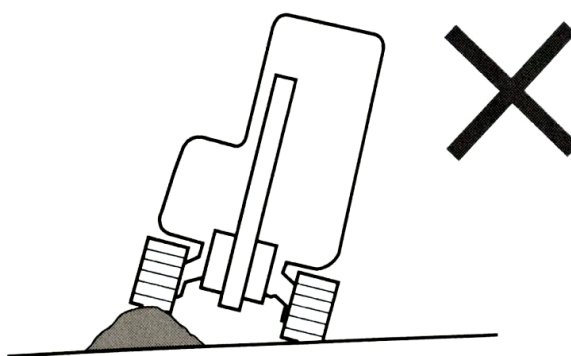

- Maintain a low speed while traversing rough terrain; avoid abrupt starts, stops, or sudden changes in direction. Such actions could cause the working device to come into contact with the ground, jeopardizing the excavator's balance and potentially causing harm to nearby structures.
- Exercise caution when navigating slopes. Ensure the excavator's stability when moving on slopes or inclines. Refrain from operating on excessively steep slopes where the excavator's stability is compromised (maximum angle: 30°, lateral tilt: 10°). The excavator's stability can vary depending on the specific work conditions, potentially falling below the mentioned values.
- Before traveling downhill, swing the cab 180° so the dozer is at your back. Adjust the arm and boom in the position as shown, and pay close attention to the slope ahead.

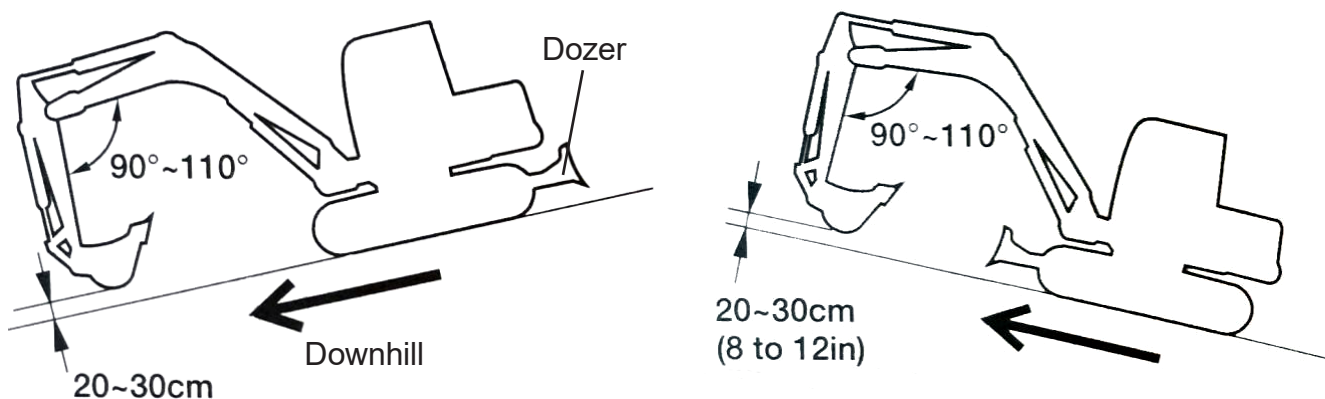

## Safety Information

- Before traveling uphill, lower the dozer and bucket to 20–30 cm above the ground and ensure the dozer is ahead. Lower the dozer into the ground and shut down the excavator in case of emergency.
- **NEVER** go backwards on slopes. The arm and boom are heavier than the cab when equipped with a crashing hammer, crusher, or a long bucket rod. **DO NOT** dig or operate laterally with a rod (boom) toward the downhill direction.
- Avoid altering your direction while on a slope or a cross slope. Instead, navigate back to level ground before selecting a new path. This approach helps maintain stability and safety during directional changes.

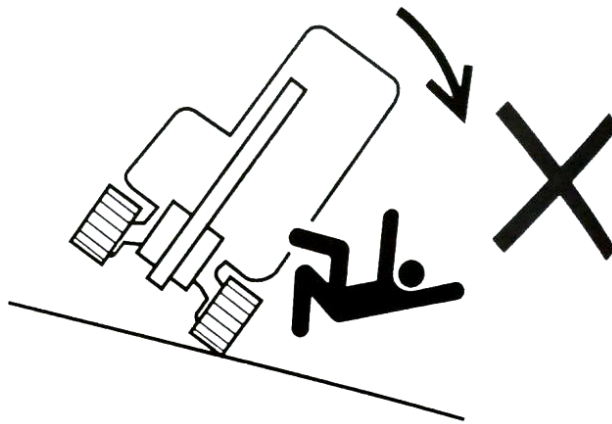

- **NEVER** swing the cab on slopes. The excavator is more susceptible to rolling in the lateral direction than the longitudinal one. Exercise caution when executing lateral turns (swings) when the bucket is heavy. **NEVER** swing the cab abruptly when the bucket carries a heavy load, even on level ground.

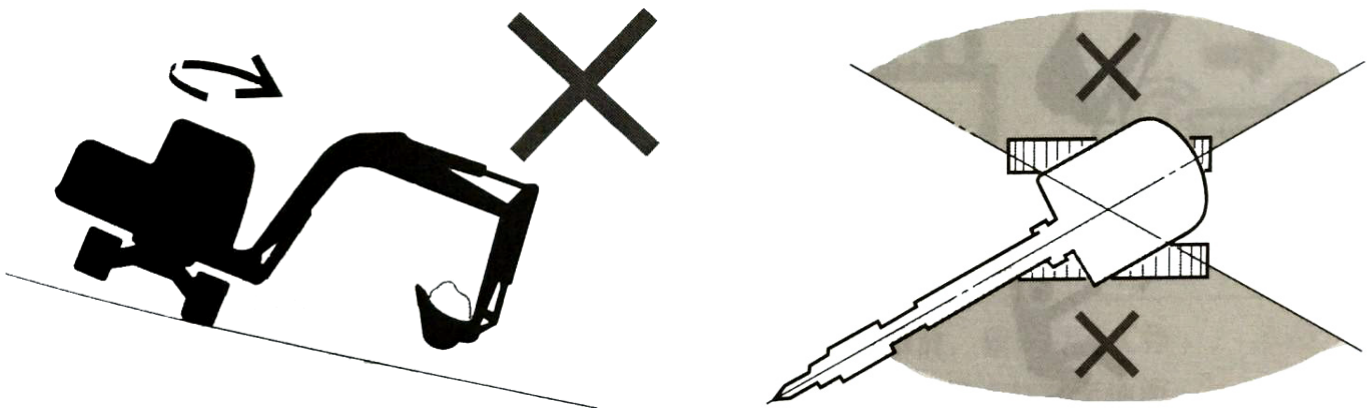

- While moving across gentle slopes covered with grass, leaves, or on wet metal plates or frozen ground, be cautious of potential slipping hazards. Ensure the excavator is not positioned sideways on the slope to prevent unintended slipping incidents.
- Exercise **EXTREME CAUTION** when operating the excavators on snow or ice. Objects on the road shoulder or roadside may be concealed beneath the snow, rendering them invisible. This poses a risk of the excavator overturning or colliding with these snow-covered objects. Therefore, exercise caution while operating the excavator in such conditions. Consult professional advice on operating an excavator under extreme weather conditions.

- Steer clear of entering areas with soft ground, as the excavator's weight may induce tilting, leading to the risk of collapse or sinking. If you find it necessary to operate in such conditions, it's advisable to seek professional guidance or assistance beforehand.

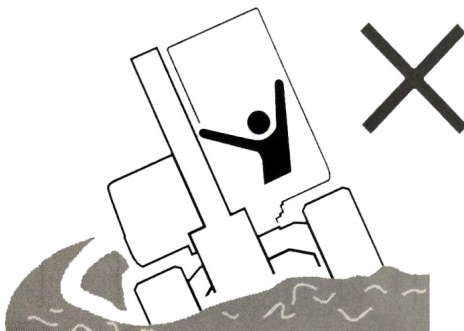

- ALWAYS AVOID** driving and turning on gravel, highly uneven hard rock, steel beams, scrap iron, or near the edge of a plate, can damage the rubber track.



- Navigating across riverbeds or ground with gravel could lead to gravel becoming lodged in the track, potentially causing track damage or derailment. Refrain from utilizing this excavator in marine environments. The salt content may corrode the steel track core.



## Safety Information

- **DO NOT** travel on newly paved asphalt roads or similarly heated surfaces, as this **WILL** compromise the service life of the rubber track. **NEVER** travel with the rubber track removed for better traction, as this **WILL** shorten the service life of the sprockets.

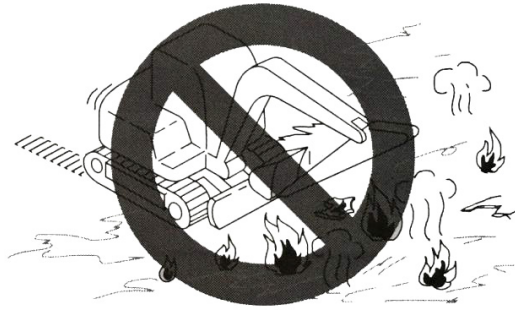

- Due to the rubber composition of the entire track, rubber tracks may not offer the same stability as steel tracks. Exercise caution during lateral turns and swings.

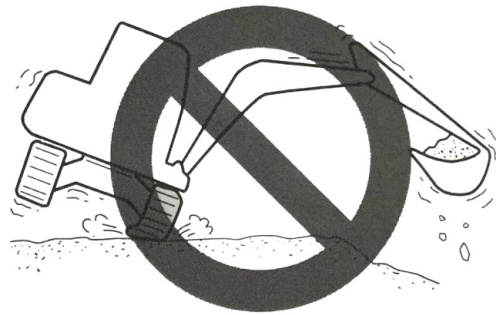

- When the vehicle encounters obstacles like pebbles, rocks, or other substantial steps (20 cm or higher), ascend at a perpendicular angle without changing direction on the steps.



- **DO NOT** change the direction as you go up a slope.

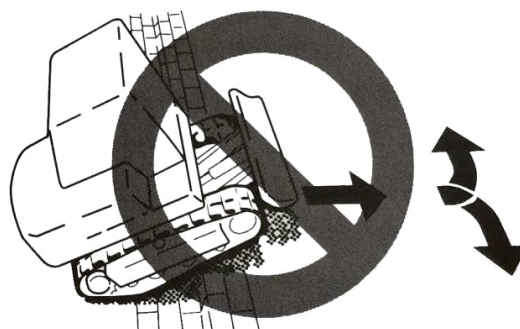

- Refrain from positioning one track on a slope or protruding surface while the other track is on a flat area (where the excavator inclines  $10^\circ$  or higher). Travel with both tracks on the flat surface.



- NEVER** change direction or swing the cab when the track is loose, as shown. If the excavator travels in reverse, the sprockets **WILL** derail from the rubber track. Similarly, the track **WILL** detach if you swing the cab in any direction.

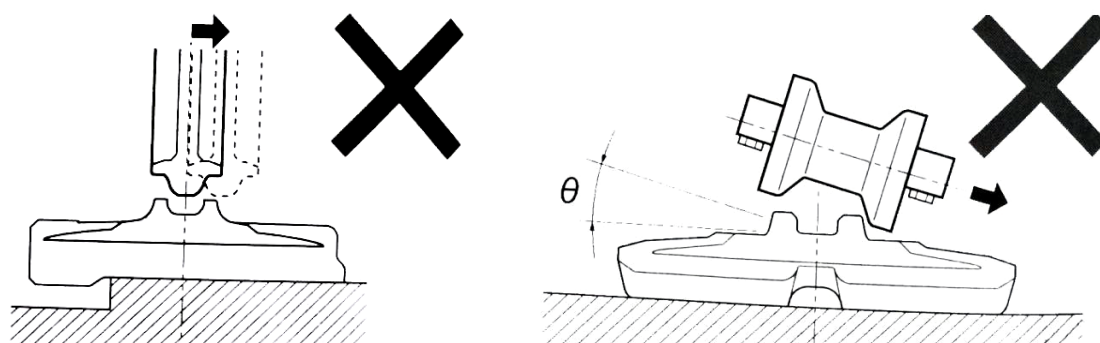

## Load & Unload Safety

- NEVER** raise the bucket over any persons, not even a driver sitting in the cockpit.
- ALWAYS** ensure the driver's safety when loading. Do not apply the load until the driver arrives at a safe place. **ONLY** load/unload from the back of a vehicle.

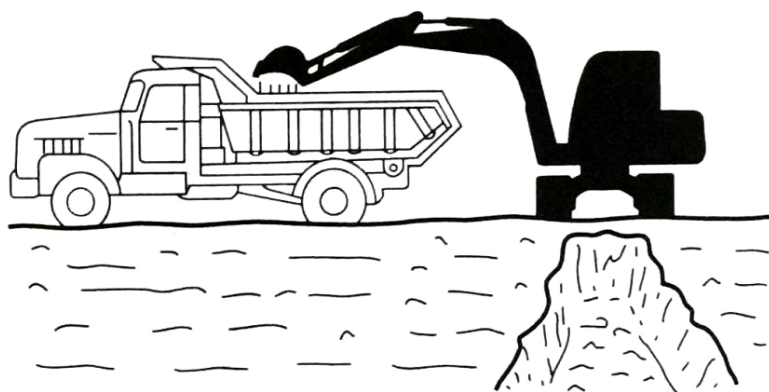

## Excavation Safety

- **NEVER** excavate at the base of steep embankments, as this can trigger ground subsidence and pose significant risks. Refrain from operating the excavator in areas prone to falling rocks or debris, as this presents a hazardous environment.

Keep a safe distance between the excavator and the edge of the site. **NEVER** dig the ground in front of the excavator when near an edge.

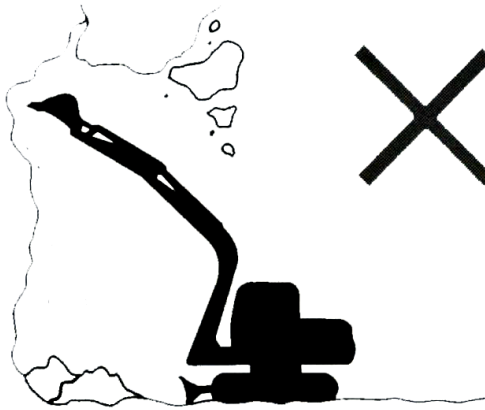

- Refrain from disassembling components underneath the excavator. The unstable ground could result in the excavator tipping over. Before operating atop a building or other structure, thoroughly assess their strength and structural integrity. In the event of a collapse, it could lead to substantial damage or destruction.

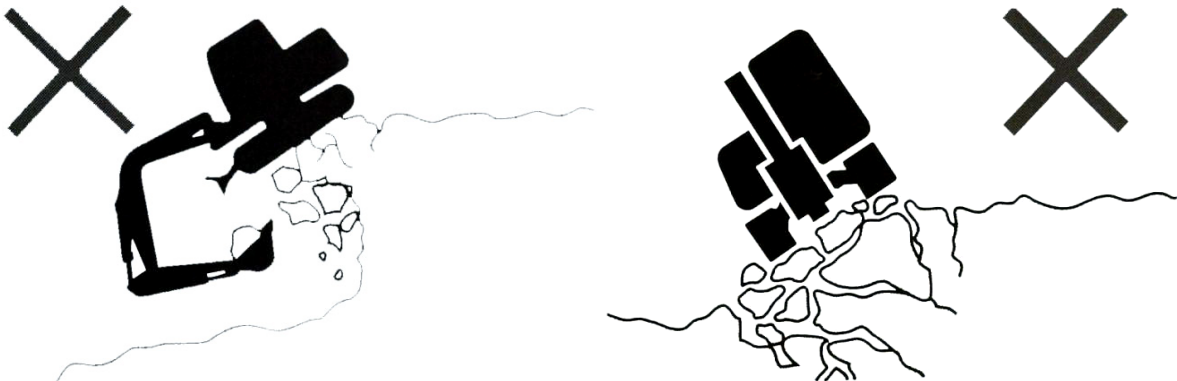

- Avoid excavating from an elevated position. This poses a risk of objects falling or buildings collapsing, potentially causing severe injuries or significant destruction.

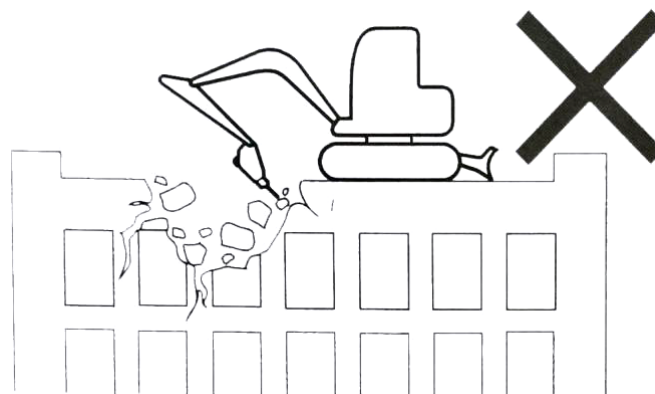



- **NEVER** disassemble from under a bridge or similar structures, as you can be crushed with brutal force—causing severe injuries, death, or significant destruction.

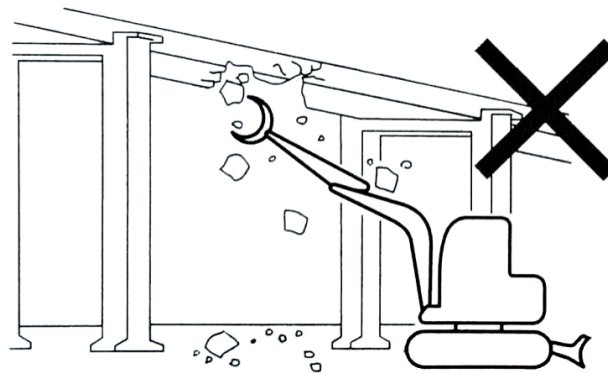

- **NEVER** use the boom and arm to swing and smash against structures for demolition purposes. This action can propel heavy debris forcefully, leading to substantial property damage, severe personal injuries, or even loss of life.

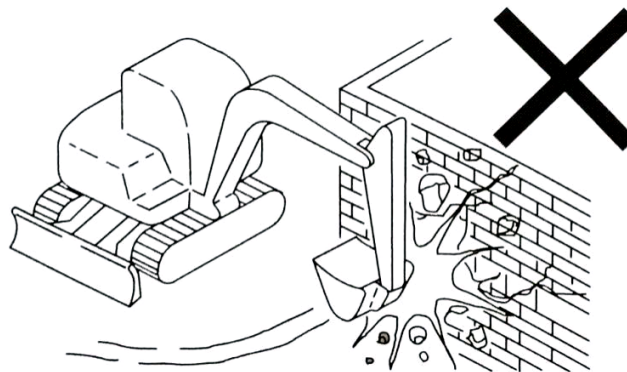

## Hoisting Safety

- All rated lifting capacities are determined under the assumption of stable and level ground conditions. For secure lifting, users must incorporate appropriate safety margins when encountering specialized work conditions, such as soft or uneven terrain, non-horizontal surfaces, lateral loads, sudden or dynamic loads, hazardous environments, and personnel experience. Prior to operating the excavator, operators and other personnel must be well-acquainted with the operation manual and adhere strictly to the equipment's safety operation procedures.
- If the chain or hoisting device isn't properly connected, the bucket linkage or hoisting device might fail, leading to severe injury or even fatalities.
- While using the excavator as a crane, abstain from attempting to extract stumps from the ground, as the load on the excavator becomes uncertain under such circumstances.
- It is strictly prohibited for anyone to be positioned above, below, or near the lifted object, or within the vicinity of the working area. Exercise vigilance regarding airborne debris.
- This excavator lacks protective equipment to shield the operator from airborne debris. Hence, refrain from using this excavator in hazardous locations where the operator is susceptible to being struck by flying debris.

## Hydraulic Cylinders Safety

- **DO NOT** extend the hydraulic cylinders past the max length.

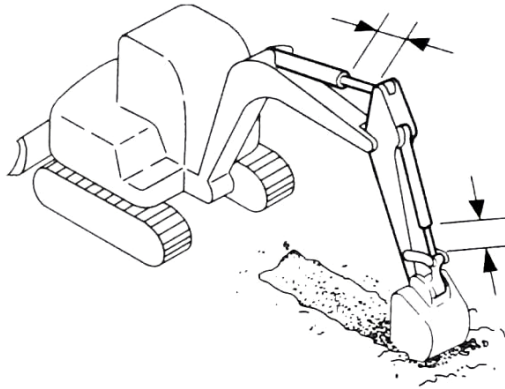

- **NEVER** raise the whole excavator by lowering the dozer. The entire weight of the excavator and driver **WILL** damage the dozer cylinder. **NEVER** use the dozer for digging.

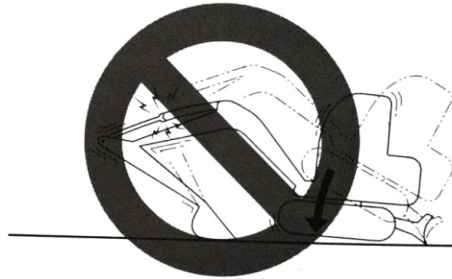

- **AVOID** forcefully striking the bucket against the ground. This **WILL** damage the boom and arm cylinders, along with other crucial connections.



- **DO NOT** use the boom and arm to support the full weight of the excavator, as this **WILL** damage the hydraulic systems and pose a hazard to the operator and other personnel.



- When dealing with hard rock, employ a crushing hammer (not included) to break the rock into smaller fragments. This approach safeguards the excavator from potential damage and proves more cost-effective.

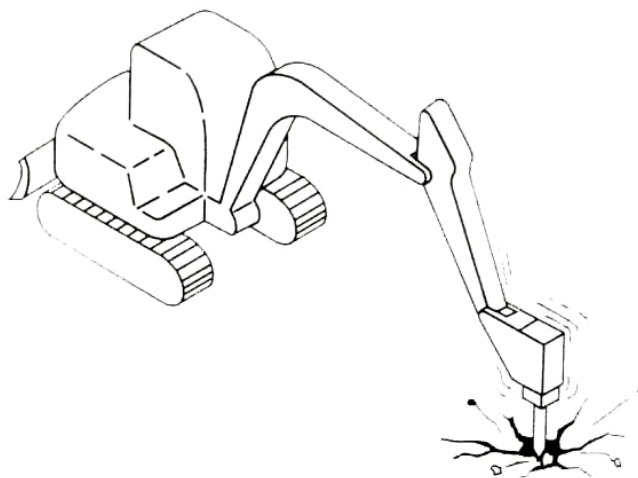

- Striking rocks with the dozer can damage both the dozer and its cylinder. Take caution when retracting the dozer.



- Pay attention to the position of your dozer's control rod when digging. Make sure the dozer doesn't drop accidentally.



## Safety Information

- When deep digging with the front blade, exercise caution to prevent collision to the boom, dozer, and bucket. Swing the cab so the dozer is at the rear. Exercise caution as you dig, being careful not to carry too heavy a load.

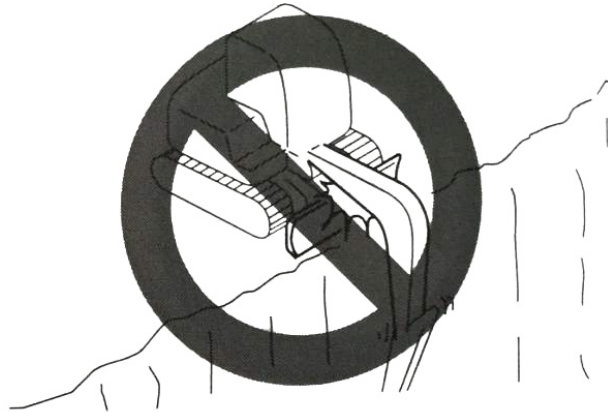

## Water Safety

- **NEVER** submerge the cab in water. This will immerse the radiator and burn it. If you must operate in water, ensure the water doesn't cover the whole track. Apply sufficient lubricating oil for any parts that have been underwater when on land.

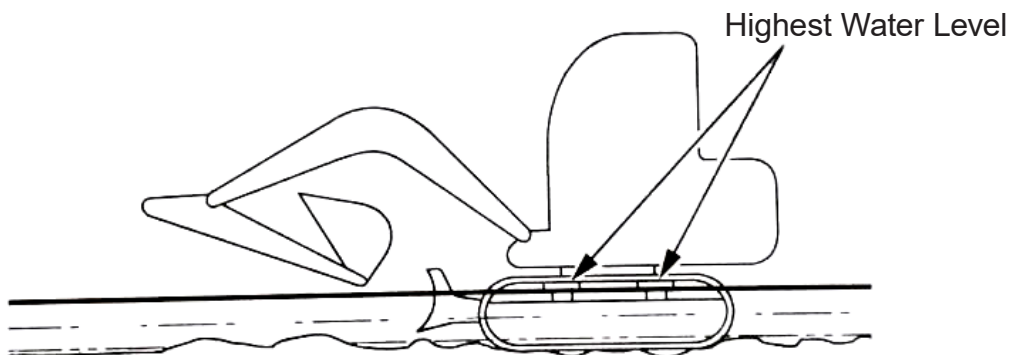

- **ONLY** wade through water when you know it cannot compromise the safe operation of the excavator and your personal safety. Drive through at a stable, slow speed.

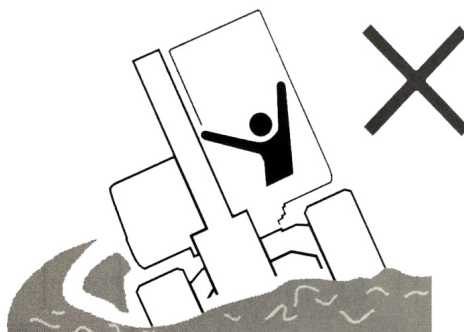

## Mud Escaping

### One-Track Entrapment

Follow the steps below to escape mud entrapment.

1. Check if just one of the tracks is trapped. If so, proceed to the next step. If not, see the below for both tracks' entrapment.
2. Set the angle between the arm and boom to somewhere between  $90^\circ$  and  $110^\circ$ .
3. Retract the bucket, lay the bottom against sturdy ground, and raise the bucket to raise the whole excavator up.
4. Lay a sturdy plank under the raised track. Raise the bucket and move out of the entrapment.



### Two-Track Entrapment

1. Repeat steps 1–3 in One-Track Entrapment.
2. Lay two sturdy planks or similar-shaped objects under the lifted tracks, ensuring the planks are inserted into the end of the tracks.
3. Use the bucket as a leverage point while traveling out of the entrapment.

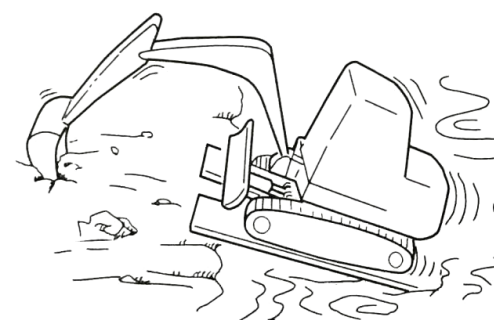

## Parking Safety

- Park the excavator on flat, solid, safe ground if possible. If such a parking surface is unavailable, make sure you park it as shown.

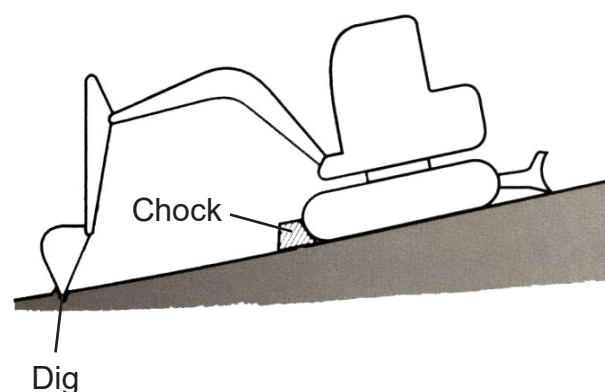
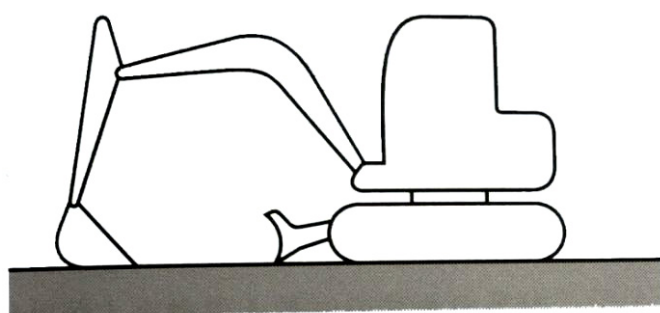

## Worksite Safety

### Danger!

- **ALWAYS** keep your worksite free of any sparks or flame. The fuel, lubricating oil, grease, and anti-freeze inside the excavator are flammable. Keep the welding and soldering devices away from the excavator.
- **NEVER** smoke at and around the worksite.
- **NEVER** use your cellphone or any other similar device when filling the fuel or lubricating oil.
- Keep your worksite well-lit at all times. Use additional illumination when necessary. **DO NOT** operate the excavator if you don't have a clear vision.



- Keep your worksite well-ventilated. **NEVER** operate your excavator in a closed area with poor ventilation. If natural ventilation is impossible, install a fan and lengthen the exhaust pipe to ensure the fume doesn't get denser inside the closed worksite.

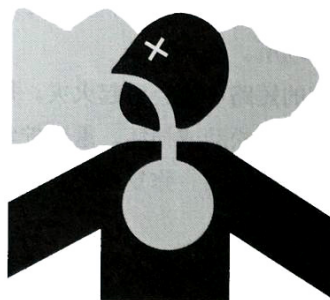

- Some construction materials may contain asbestos. Exercise **EXTREME** care and discretion when dealing with the material. Ensure all personnel wear either a half-face or full-face respirator paired with a **NIOSH-rated N100, R100**, or the more common P100 filter.

Do not use compressed air to clean your worksite. **DO NOT** polish or grind materials containing asbestos. If working indoors and there is asbestos dust, all personnel must wear a respirator. Install a ventilation system with a polymer filter before working on material containing asbestos. Limit authorized personnel access to the worksite and follow the national and local codes and regulations concerning the disposal and handling of asbestos.

- **DO NOT** put any body part into any moving parts of the excavator. The clearance may change when the excavator moves. Inform your ground personnel, evacuate any bystanders, and enclose your worksite with barriers or hurdles before operation.



- **ALWAYS** inspect the terrain and the ground in the worksite before operation. Inspect the building structure for indoor operation, ensuring the structure can bear the operating mass of the excavator. When walking on a structure like a bridge, make sure the structure can bear the operating mass of the excavator.

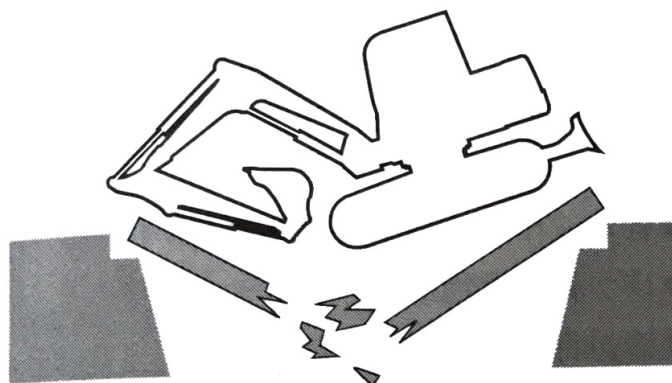

- **DO NOT** operate on soft or damp soil ground, on which this excavator may tilt or fall over. **DO NOT** operate on unstable ground. If the ground vibrates or shakes as you drive, cease driving and exit the excavator immediately.
- **ALWAYS** know the locations of obstacles such as ditches, utility lines (such as gas, power, water), and things that might fall (like trees, overhead wires, or stones on a cliff).

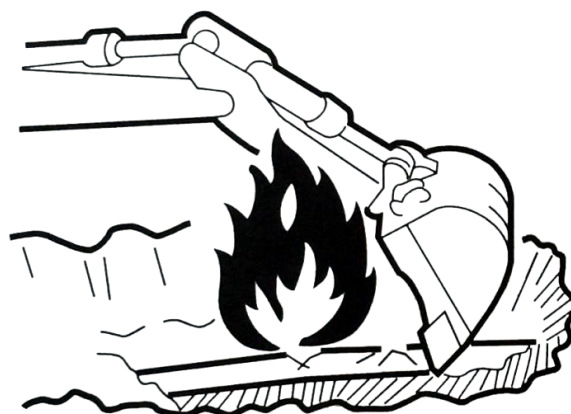

## Oil Safety

- **DO NOT** remove the fuel tank cap or fill the fuel while the engine is running or still hot. When filling oil, watch out not to splash the oil onto the excavator's hot surfaces or electronic components.
- Smoking should be **PROHIBITED** on the worksite.
- **IMMEDIATELY** clean the fuel or lubricating oil overspills.
- **AWLAYS** wait till the engine has cooled before refueling. Always fill the fuel tank in a well-ventilated location. Refuel carefully and clean overspills or splashes **IMMEDIATELY**.
- Avoid filling the fuel tank to maximum capacity; leave room for oil expansion. Immediately address any fuel spillage. Ensure the fuel tank is securely fastened. If the tank cover is absent, replace it with an identical one. Refrain from using unauthorized tank covers that lack proper ventilation, as this could lead to internal pressure buildup.
- For better engine performance and longer service life, consistently use clean and high-quality fuel. In cold weather conditions, opt for diesel oil that can function efficiently at temperatures of at least 12°C lower than the anticipated minimum outdoor temperature to prevent freezing.
- Use diesel oil with a cetane value of 45 or higher. In cold regions or areas at high altitudes, opt for fuel with a higher cetane value.
- Ensure that the fuel used contains sulfur content below 0.05–0.0015%. In the United States or Canada, employ ultra-low sulfur fuel. The use of high-sulfur fuel may result in acid corrosion of the engine cylinder.
- Avoid the use of kerosene. Refrain from mixing kerosene, used lubricating oil, residual fuel, or other additives with diesel oil. Poor-quality fuel can undermine engine performance or cause damage.
- Fuel additives are not recommended, as some additives may degrade engine performance. Additionally, metals like zinc, sodium, magnesium, silicon, and aluminum should be limited to one part per million (1 ppm mass) or less.
- When utilizing bio-diesel, adhere to safety guidelines. Warranty provisions from the engine manufacturer may become void if the excavator does not meet the required standard or if deteriorated bio-diesel is used.

## Maintenance Safety

- **ONLY** replace damaged parts with identical ones. If such parts can't be procured locally, contact Customer Service.

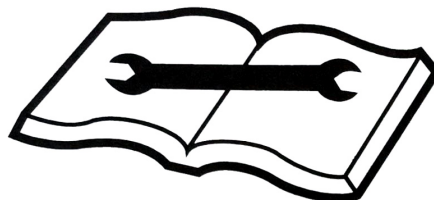

- **ONLY** replace damaged parts with identical ones. If such parts can't be procured locally, contact the Customer Service.
- **DO NOT** modify the excavator. Unauthorized retrofitting of the excavator may cause injury or even death, for which the manufacturer and importer of the excavator will not be held liable.
- **ALWAYS** check that the labels and signages are legible. If damaged, replace them with identical ones.



- **ALWAYS** keep the excavator clean, especially parts that the driver steps on or holds on to. Wipe grim, grease, dirt, snow, or ice off of them to prevent accidental falling.
- **ALWAYS** check the inlets and outlets of the engine for any obstructions.

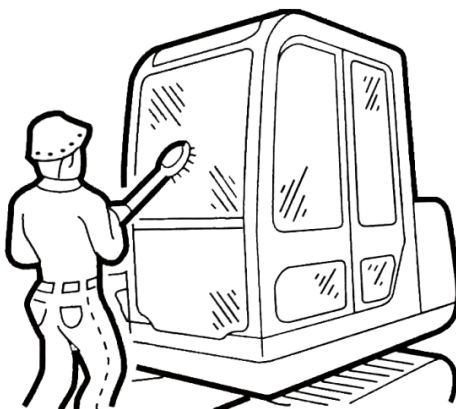

- Prevent fuel, lubricating oil, salt, or chemical solvents from coming into contact with the track. These substances can corrode the welding seams of the track steel core, leading to rust or detachment. Should any of these substances adhere to the track, promptly rinse it off with water.

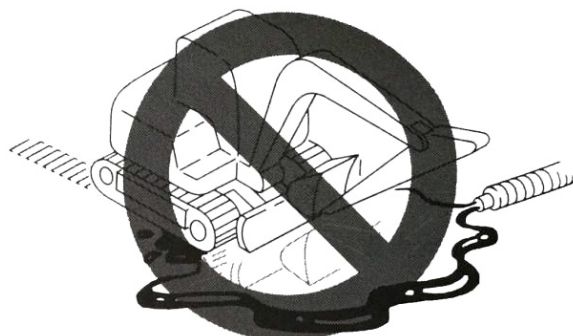

- **ALWAYS** mark the excavator with a “**DO NOT OPERATE**” sign if any malfunction arises. Hang the sign in a prominent location, preferably on the joysticks.



## Safety Information

- Use explosion-proof lamps when examining fuel, lubricating oil, coolant, or battery electrolyte. Failure to do so could lead to severe injuries or fatalities caused by an explosion.



- **NEVER** use damaged tools, tools with poor performance, or tools with other purposes to service this excavator.

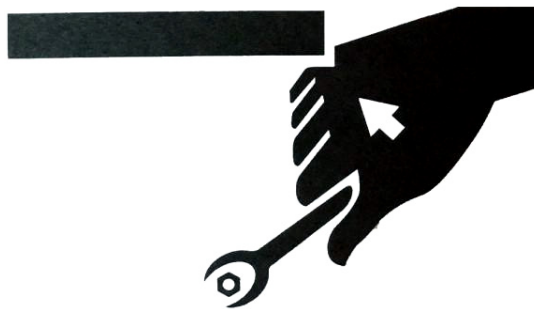

- **ALWAYS** be mindful of the rotating and moving parts. **NEVER** drop or insert any objects into a fan or fan belt, which could tear the objects into pieces and send them flying.

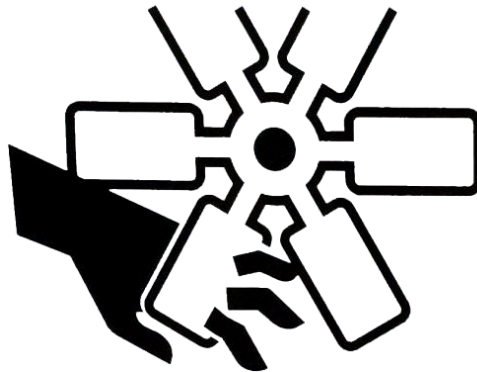

- **ALWAYS** lower all the movable working equipment onto the ground or at the lowest position before maintenance or repair under the excavator.



- **ALWAYS** make sure to immobilize the tracks using chocks before performing any work beneath the raised excavator or equipment. Always use a sturdy and stable support such as a wooden block or jack to ensure secure fixation. Do not engage in any work under the excavator or the working device if the equipment isn't stably fixed.
- **ALWAYS** secure the hood before servicing under it.

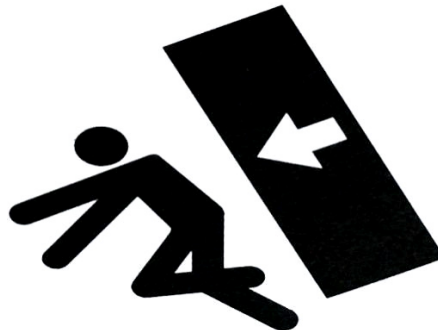

- When handling heavy objects or accessories during removal or installation, ensure they are secure and stable. Restrict unauthorized individuals from accessing the area where such items are stored.
- Refrain from lubricating or mechanically adjusting the excavator when the engine is active, even if the excavator is not operating. If maintenance must be carried out, use at least two operators. One should be seated in the driver's seat, prepared to promptly shut down the engine if necessary. Do not touch the control rods/joysticks. The other person performing maintenance should stay clear of moving parts.
- Salt, potassium chloride, ammonium sulfate, potassium sulfate, and lime superphosphate can damage the track. If any such substances stick to the track, clean it immediately with water.
- If the excavator will not be used for a prolonged period (three months or longer), disassemble the rubber tracks and store them away from direct sunlight or rain. You can also cover them completely with water-repellent canvas.

# Specifications

<b>Model</b>		<b>AX-16</b>	
<b>Engine</b>	<b>Model</b>	BRIGGS & STRATTON 3864	
	<b>Rated Power</b>	23 hp	
	<b>Rated Speed</b>	3600 rpm	
	<b>Rated Torque</b>	35 ft lb. / 47.5 Nm @ 3060 rpm	
	<b>Displacement</b>	38.3 in <sup>3</sup>	627 cm <sup>3</sup>
	<b>Oil</b>	57.5 fl oz	1.7 L
		10W-30	
<b>Fuel Tank Volume</b>		2.12 gal.	8 L
<b>Max. Traveling Speed</b>		3km/h	
<b>Fuel Consumption</b>		0.4 gal/h	1.5 L/h
<b>Fuel Type</b>		#90 or over	
<b>Main Pump</b>	<b>Model</b>	PGP5144MHHR1K	
	<b>Rated Pressure</b>	2610.28 psi	18 MPa
	<b>Max. Pressure</b>	3626.43 psi	25 MPa
	<b>Nominal Flow</b>	0.27 fl oz/r	8 ml/r
	<b>Hydraulic Oil</b>	AW 46	
	<b>Oil Flow</b>	6.6 gal/min	25 L/min
<b>Slewing Speed</b>		11 rpm	
<b>Hydraulic Tank Volume</b>		3.4 gal.	12.7 L
<b>Travel Motor Model</b>		BM6-310	
<b>Track Width</b>		7.1 in.	180 mm
<b>Supporting Wheel No.</b>		2	
<b>Overall Track Length</b>		48.5 in.	1230 mm
<b>Platform Ground Clearance</b>		14.6 in.	370 mm
<b>Min. Clearance</b>		3.8 in.	98 mm
<b>Min. Swing Radius</b>		61.5 in.	1560 mm
<b>Bucket Volume</b>		0.88 ft <sup>3</sup>	0.025 m <sup>3</sup>
<b>Bucket Width</b>		15.7 in.	400 mm
<b>Overall Height</b>		7.3 ft.	2200 mm
<b>Max. Bucket Digging Force</b>		3261.96 lbf	14.5 kN
<b>Max. Passenger Capacity</b>		264.5 lb.	120 kg
<b>Max. Digging Depth</b>		70.6 in.	1795 mm
<b>Max. Vertical Digging Depth</b>		62.8 in.	1595 mm
<b>Maximum Dumping Height</b>		59.2 in.	1505 mm
<b>Max. Digging Radius</b>		114.2 in.	2900 mm
<b>Dozer Height</b>		12.2 in.	310 mm
<b>Max. Dozer Depth</b>		10.6 in.	270 mm
<b>Max Slope Grade</b>		30°	
<b>Weight</b>		1940 lb.	880 kg

# Assembly

## Installing the Cover

1. Use at least 3 people to unpack the package. Check that the excavator is intact and free of any damage. The cover and frame of your excavator should arrive uninstalled.
2. Remove the bolts located around the four corners of the driver's seat. There should be 4 on each of the front right and left corners and 2 on each rear left and right corners.
3. Have two people lift the cover and its frame to where it should be installed. Align the holes on the frame base with the ones on the excavator.
4. Tighten the bolts.



**WARNING! NEVER** operate the excavator with its cover removed.

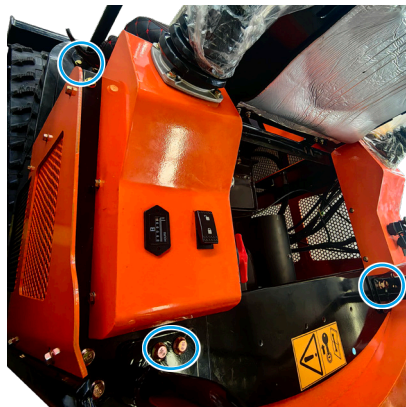

## Changing the Work Equipment

1. Your excavator should arrive with the bucket uninstalled.



The bucket is fastened to the arm through two bolts and nuts. Installation and removal of the bolts require strength and care. Always wear protection and exercise care. Use at least two people to handle the bucket.

2. Ensure the machine is parked on level ground. Lower the bucket's flat surface onto the ground to prevent bucket movement.
3. Remove the two nuts at the upfront as shown. Remove the bolts and keep them where they won't be compromised by metal debris or sand grains.

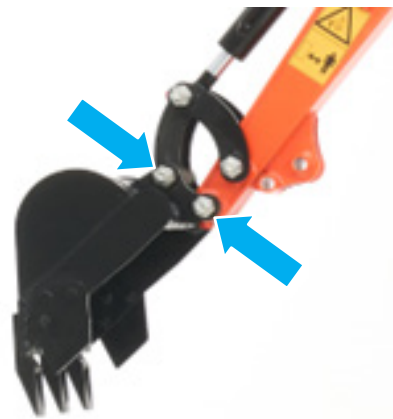

4. Have two people carry the work equipment to be installed and align it with the two holes on the arm.
5. Replace the bolts and tighten the nuts.

# Operation

## Starting the Engine

1. Circle the excavator to check for anomalies, inform the coworkers of the imminent task, and tell the signalman/flagman to stand by.
2. Enter the cab in the way depicted. Sit in the driver's seat, checking that there are no obstructions on the dashboard or around the joysticks. If you see any signs indicating the excavator is out of order, exit the cab.
3. Fasten the seat belt and buckle up. Check all control rods/joysticks are in neutral position. If not, reset them to neutral.
4. Locate the red power switch on your left near the seat. Turn while pulling the switch in the direction indicated by the label around it.

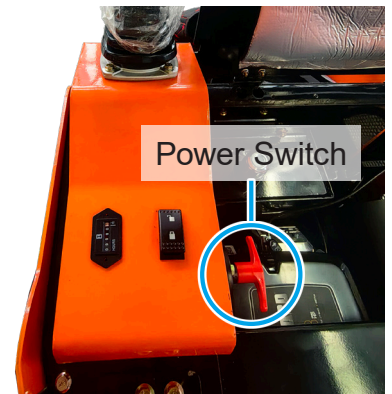

5. Locate the throttle lever, which should look as shown. Hold its end, hold down the button located on top, and push the lever away from you.





6. Insert the ignition key and turn it clockwise to start the engine.

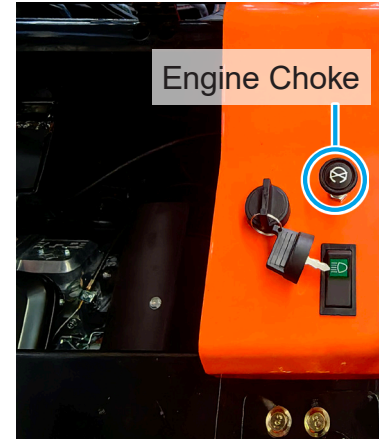

- If you are operating at a high altitude or the specific conditions make it hard for the engine to start, pull the engine choke knob a little bit to facilitate the ignition.

Remember to replace it when the engine has started.



- Flip the hydraulic pilot lock switch to  to unlock the hydraulic system.

Remember to flip it to  before turning off the engine.

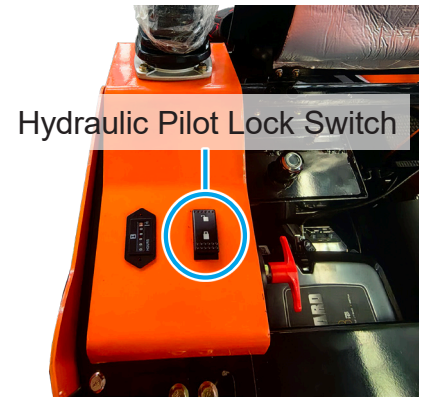

## Headlights

Locate the headlights button. It should look like the picture shown. Turn it on and off to check that the headlights light up and shut off.



The headlights may not be bright enough for all working conditions. Use additional illumination when needed. Remember to turn off the lights when you turn off the engine.



## Excavation Timer

There is an excavation timer located as shown. It works automatically as soon as the power is turned on, recording the total working hours of the whole system. Be aware that the timer is not resettable and will keep increasing.

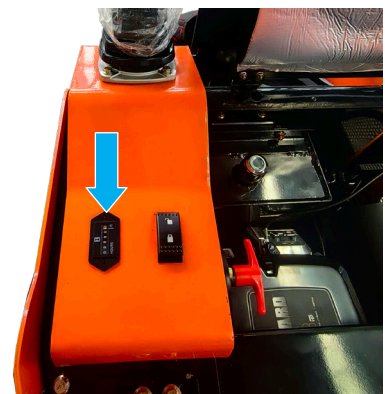

## Forward & Backward Travel & Steering

1. After running the routine safety checks and starting the engine following the protocols stated in the section “Starting the Engine,” wait for a couple of minutes for the engine and hydraulic oil to warm up.
2. The two adjacent rods in the middle control the travel.
  - To move your excavator forward, push them together away from you.
  - To move your excavator backward, push them together towards you.
  - To move only one of the tracks, push or pull either of the two travel rods.
  - To turn left while traveling, push the right rod of the travel rods while releasing the left one.
  - To turn right while traveling, push the left rod of the travel rods while releasing the right one.

 **Caution!** When mobile, **NEVER** push one rod while pulling the other. This **WILL** topple the excavator.



3. To move faster, use the throttle lever. Repeat the normal steps for starting up. Locate the throttle lever, which should look as shown. Hold its end, hold down the button located on top, and push the lever away from you. This will increase the engine's output power.

 Adjust the throttle **ONLY** after starting the engine. **NEVER** do this when the excavator is mobile, as you should focus on the work at hand.





## Basic Excavation

1. Follow the normal safety protocols and start the engine. Steer the excavator to where the digging will be, ensuring you are driving on a surface strong enough to handle the mass of your excavator.
2. Refer to the figure below for a basic understanding of the excavation control rods/joysticks.

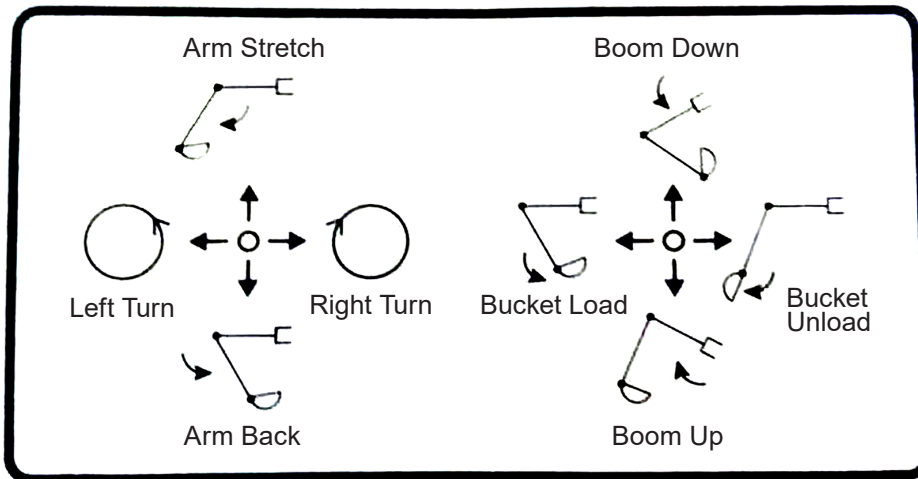

3. Start excavating with the two joysticks.



### The left joystick controls the arm and swing:

- To raise the arm (aka dipper, stick, or crowd), push it forward.
- To retract the arm, pull it toward you.
- To swing the cab left, push it to your left.
- To swing the cab right, push it to your right.

### The right joystick controls the boom and bucket:

- To lower the boom, push it forward.
- To raise the boom, pull it toward you.
- To load the bucket, push it left.
- To unload the bucket, push it right.



For better results on hard ground, angle the dipper (aka arm, stick, or crowd) cylinder roughly perpendicular to the dipper and bucket 30° to the ground so that you exert the largest excavating force. For soft ground, angle the bucket 60° to the ground.

Achieving a seamless mastery of excavation demands consistent practice, honed skills, and proficient handling of the excavator. Prior to actual operation, engage in practice sessions at an open area that is robust enough to support the excavator's movement safely and devoid of any onlookers. For optimal outcomes, consider seeking guidance from an experienced excavator owner or enrolling in professional training.



### Basic Bulldozing



**ALWAYS** make sure the rods are at neutral before power up the whole system.

1. Make sure that your excavator has started and warmed up.
2. Steer the excavator to where the bulldozing is expected to be carried out.
3. Start bulldozing with the leftmost rod of the four adjacent control rods.
  - To raise the dozer, pull it towards you.
  - To lower the dozer, push it away.



### Leveling

1. Position the dozer working device in proximity to the excavator.
2. Gradually push the soil from the side of the mound.
3. As the mound reduces in height, shift the topsoil from the peak. If the load places excessive strain on the machine, adjust by raising or lowering the dozer.

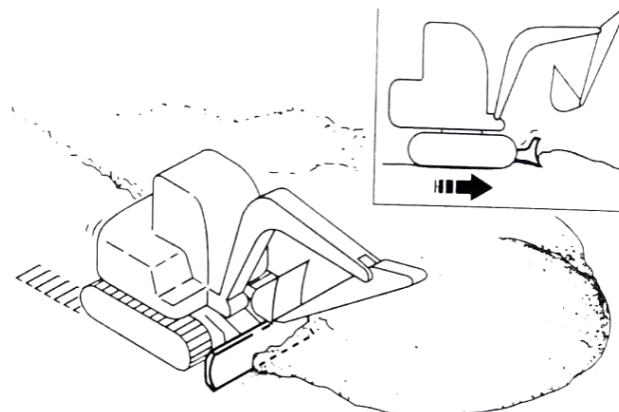



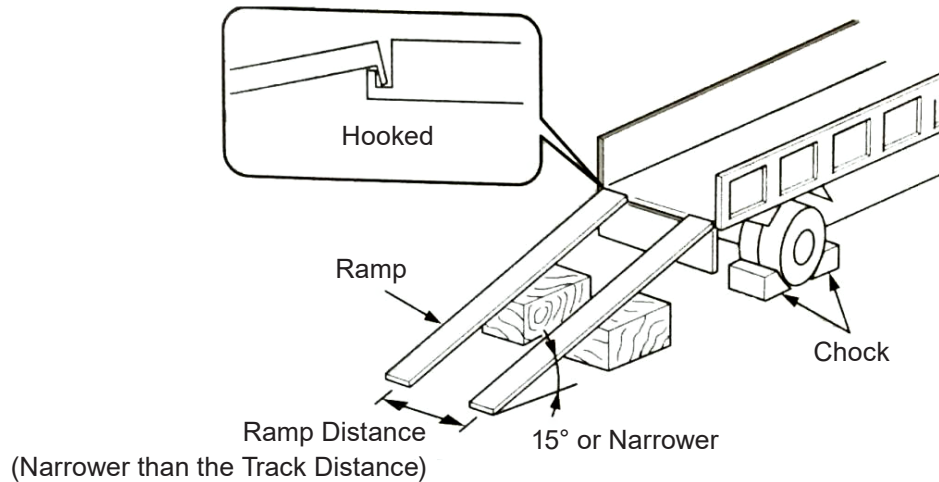

## Transportation

1. Select a sturdy, level area at a safe distance from the roadside.
2. Place a warning sign near the transportation area to alert passing pedestrians and vehicles.
3. Securely fasten two ramps with adequate strength and dimensions to the truck bed. The incline angle must not exceed 15°. Use a support pillar or block underneath if the ramp is too steep.

Make certain that the ramps are wide enough for full contact with both tracks. Refer to the picture below for the truck and ramp preparation.



-  Do not employ the working device for loading or unloading the excavator, as this could result in rolling or falling.
  -  Ensure the truck and loading surface are clean and devoid of oil, sand, ice, snow, or any foreign materials that can cause the excavator to slide. Clear the tracks.
4. Steer the excavator to travel slowly onto the ramps, ensuring the tracks are fully on the ramp.
  -  **Danger! DO NOT** change direction when on the ramps. Travel slowly and steadily.
  6. Flip the hydraulic pilot lock switch to , turn off the engine, ensure all control rods/joysticks are in neutral, and remove the key.
  7. Use chocks to immobilize the tracks and prevent movement. Secure the machine to the truck using cables or chains if possible. Lock the trunk doors and lids, if any.

# Maintenance

Refer to the excavation timer located as shown. Maintain your excavator according to the schedules below.

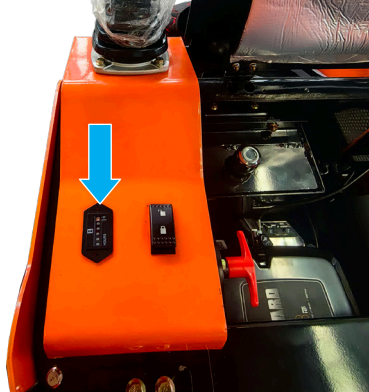

## General Maintenance Schedule

NO.	Item	Qty.	Interval (h)	
			10	50
1	Engine Oil Level	1	★	
2	Hydraulic Oil Level	1	★	
3	Fuel Level	1		★
4	Oil-Water Separator	1		★
5	Fuel Pipe Check.	----	★	
6	Work Equipment Pivots	----	★	
7	Hydraulic Hose & Pipelines	----	★	
8	Bucket Teeth	4		★
9	Seat Belt	1	★	
10	Bolts and Nuts Torque	----		●

### Note:

- ★: Routine Maintenance Interval
- : Maintenance Prior to Initial Use

## Greasing, Replacement & Periodical Check Schedule

No.	Item	Interval (h)							
		100	250	500	1000	1500	2000	2500	4000
1	Greasing of Slewing Bearing		★						
2	Greasing of Slewing Bearing Gears	★							
3	Changing Engine Oil	●	▲	★					
4	Changing Hydraulic Oil					△	★	△	
5	Changing Hydraulic Oil Suction Filter Elements				★				
6	Fuel Pipe Crack/Bent Check		★						
7	Changing of Oil-Water Separator			★					
8	Fuel Hose Leakage/Crack Check		★						
9	Fuel Hose Leakage/Crack Check		★						
10	Changing the Bucket								
11	Connection of Bucket								
12	Remove the Traveling Handle								
13	Replace the seat belt								
14	Track Defection Check			★					
15	Tensioner Maintenance			★		★			

### Note:

★: Routine maintenance Interval

▲: Maintenance interval of engine oil

△: In situations where crushing conditions are frequent, halve the replacement intervals for hydraulic oil and filters.

☆: Under the dusty environment, shorten the maintenance interval.

## Work Equipment Pins Lubrication

Parts		Qty.	Interval (h)						
			10	50	100	250	500	1000	2000
Pivots	Boom Base Pivot	10							
	Boom Base Cylinder Pivot		★						
	Bucket and Connecting Rod Pivots		★						
	Others	6	★						
Slewing	Slewing Bearing	2				★			
	Slewing Bearing External Meshing Gear	1					★		

### Note:

Using lithium grease is recommended.

★: Routine Maintenance interval

## Locations of Work Equipment Pins

- Pivot between bucket and connecting rod

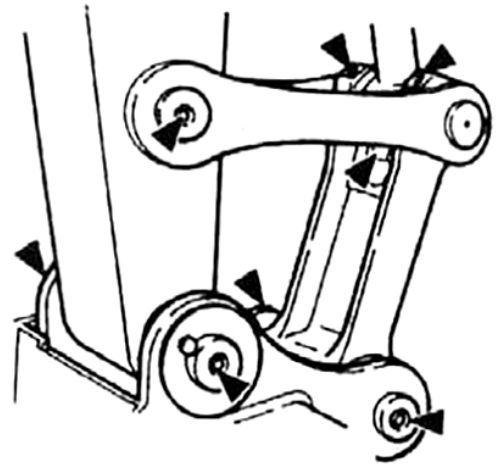

- Pivot at base of boom



- Pivot at base of boom cylinder



- Others

Pivot between boom and arm; pivot of arm cylinder plunger; pivot at base of bucket cylinder.

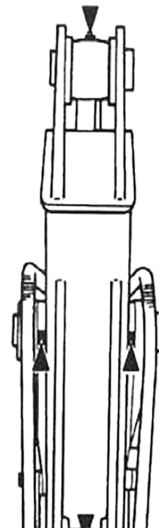

## Lubricating the Slew Bearing

1. Position the excavator on level ground.
2. Lower the bucket to the ground.
3. Allow the engine to idle at low speed for 5 minutes.
4. Flip the hydraulic pilot lock switch to , turn off the engine, ensure all control rods/joysticks are in neutral, and remove the key.
5. While the upper structure remains stationary, apply grease to the two grease nozzles until the old grease overflows.



**DO NOT** over-grease, as it can damage the seal of the swing support, leading to grease leaks and the entry of dust, exacerbating wear and tear.

6. Initiate the engine to raise the bucket clear of the ground. Rotate the cab by 45 degrees (1/8 circle).
7. Repeat steps 2–6 until the bucket rotates a full circle.

## Lubricating the Meshing Gear of Slew Bearing

1. Park the excavator on level ground. Lower the bucket to the ground. Allow the engine to idle at low speed for 5 minutes.
2. Flip the hydraulic pilot lock switch to , turn off the engine, ensure all control rods/joysticks are in neutral, and remove the key.
3. Ensure the grease is stored on the top of the external meshing gear of the slewing bearing, free from any contamination. If necessary, add approximately 0.5kg of grease. Any contaminated grease should be replaced with fresh grease.



Using lithium grease is recommended.



## Engine Maintenance

Refer to the engine's manual for engine maintenance.

## Greasing, Replacement & Periodical Check Schedule

Item	Qty.	Interval (h)								
		10	50	100	250	500	1000	1500	2500	4000
Oil Level Check	1	★								
Drain Pipe Cleaning	1				★					
Replacing	16.5L/ 4.4 gal.								★	
Suction Filter Elements Replacing	1						★			
Hose & Pipeline Check					★					
				★						
Change the hose	39									★

### Note:

★: Routine Maintenance Interval

## Checking the Hydraulic Cylinder



**Caution!** Hang a “DO NOT OPERATE” sign on the joystick to prevent accidental machine activation during inspection.



For your safety and longer service life of the hydraulic cylinders, it is recommended that you have them checked and serviced by a certified mechanist.

1. Park the excavator on a level and stable surface and stop the engine. Lower the bucket to the ground and turn off the engine.
2. Allow sufficient time for the hydraulic system to cool down completely to avoid exposure to hot and pressurized components.



**Caution!** The hydraulic system will remain hot after working. Wait for it to completely cool before handling it.

3. Bleed air completely from the hydraulic oil reservoir.
4. Visually inspect the hydraulic cylinder for any signs of leakage, such as oil spots, drips, or accumulated oil around seals and connections. Examine the cylinder's exterior surface for dents, scratches, or any damage that could affect its performance. Check the rod and piston for signs of wear, corrosion, or scoring. Run your fingers along their surfaces to detect irregularities. Gently inspect the rod seals and wiper seals for cracks, tears, or deterioration.
5. If the cylinder requires disassembly for a more thorough inspection, contact Customer Service. If any issues are detected or if the cylinder's performance is compromised, contact Customer Service.
6. Reassemble any components that were disassembled.
7. If everything is in order, remove any safety measures, start the machine, and test the hydraulic cylinder's functionality through controlled movements.



8. If you encounter any abnormal behavior or suspect an issue during testing, immediately turn off the engine and seek professional assistance.
9. Keep a detailed record of the inspection, including findings and actions taken, for future reference and maintenance tracking.

## Daily Check of Hydraulic Oil Level



**Warning ! NEVER** start the engine with no hydraulic oil.

1. Ensure the machine is parked on level ground.
2. Fully retract the arm cylinder and extend the bucket cylinder outward to position the machine. Lower the bucket until it rests on the ground.
3. Allow the engine to idle at low speed for 5 minutes.
4. Flip the hydraulic pilot lock switch to , turn off the engine, ensure all control rods/joysticks are in neutral, and remove the key.
5. Check the hydraulic oil level in the tank using the hydraulic oil meter. If the level is low, proceed with the refilling steps.
6. Locate your hydraulic oil cap and meter by referring to the pictures below.

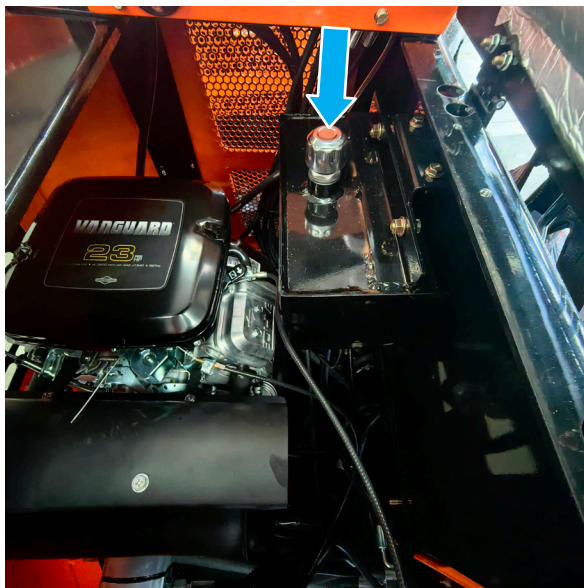

7. Infuse the recommended hydraulic oil and check the meter. Replace the cap when the level rises to as stated.



**Warning!** The hydraulic oil tank is pressurized. Before adding oil, carefully loosen the cap to release pressure slowly. Failure to do so may result in oil spraying out and causing potential hazards. Always exercise caution when working with pressurized systems.

## Replacing the Hydraulic Oil Suction Filter Element



Caution! Do not proceed until the hydraulic oil cools down, as it may be very hot.

1. Park the machine on a level surface. Fully retract the arm cylinder and extend the bucket cylinder to position the bucket to the ground. Allow the engine to idle at low speed for 5 minutes.
2. Flip the hydraulic pilot lock switch to , turn off the engine, ensure all control rods/joysticks are in neutral, and remove the key.
3. Locate the hydraulic oil cap. Clean the top of the hydraulic oil reservoir to prevent dirt from entering the system.
4. Gradually open the hydraulic oil cap to release pressure. Loosen and remove the oil-pickup filter element cap. Loosen and remove the drain plug at the bottom of the hydraulic oil tank to drain the oil.



**Warning!** The hydraulic oil tank is pressurized. Before adding oil, carefully loosen the cap to release pressure slowly. Failure to do so may result in oil spraying out and causing potential hazards. Always exercise caution when working with pressurized systems.

5. Extract the oil-pickup filter and the levers. Thoroughly clean the filter and the inside of the hydraulic tank.
6. Utilize an oil-pickup pump to extract any remaining oil residue from the tank's bottom.
7. Position the filter and levers to ensure the filter is securely attached to the outlet. Clean and reinstall the drain plug at the tank's bottom.
8. Add oil until the level is between the markers on the oil meter.

## Checking Hoses & Pipelines



**Warning!** Any sprayed fluid can penetrate your skin, resulting in serious injury. Always use a paperboard to check for leakage. Furthermore, exercise extreme caution to keep your hands and body away from pressurized oil. In the event of an accident, seek immediate medical attention from a doctor experienced in treating trauma. Any fluid that penetrates the skin must be removed within a few hours to prevent complications like gangrene.



**Warning!** Leaked hydraulic oil and lubricant may pose a fire hazard or cause personal injury.

1. Park the excavator on level ground. Lower the bucket to the ground.
2. Flip the hydraulic pilot lock switch to , turn off the engine, ensure all control rods/joysticks are in neutral, and remove the key.
3. Check the whole machine for any missing parts, loose pipe clamps, twisted hoses, pipelines, or hoses rubbing against each other. If any abnormalities are detected, refer to for replacement or tightening instructions.
4. Thoroughly tighten, repair, or replace any loose, damaged, or missing pipe clamps, hoses, pipes, oil coolers, and flange bolts. Do not bend or subject any pressure pipelines to impacts. Never install bent or damaged hoses or pipelines.
5. Securely attach the oil-pickup filter element cap, ensuring the filter and levers are correctly positioned, then tighten the bolts to 49 Nm.

6. Important: Starting the engine without hydraulic oil may damage the hydraulic pump.
7. Tighten the oil tank cap.
8. With the engine idling at low speed, gradually operate the lever for 15 minutes to purge air from the hydraulic system.
9. Fully retract the arm cylinder and extend the bucket cylinder to position the machine. Lower the bucket to the ground. Turn off the engine. Remove the ignition key. Check the hydraulic oil level in the tank and add more if necessary.

## Checking the Battery

- For a longer battery life, turn off the headlights when not needed.
- For a longer battery life, the single ignition time should not exceed 10 seconds, and there should be a minimum interval of 60 seconds between two ignitions.  
If the machine fails to ignite three times in a row, stop igniting and proceed with troubleshooting.
- If you find it hard to start the engine, replace the battery with an identical one.

## Checking the Bucket Teeth

Check if the bucket teeth are worn or loosened daily. Replace them with new one if they have become shorter than 5.2 inch (130 mm).

 **Warning!** Exercise extreme care when changing the teeth. Wear goggles or safety protections.

## Changing the Work Equipment

1. Your excavator should arrive with the bucket uninstalled.

 The bucket is fastened to the arm through two bolts and nuts. Installation and removal of the bolts requires strength and care. Always wear protection and exercise care. Use at least two people to handle the bucket.

2. Ensure the machine is parked on level ground. Lower the bucket's flat surface onto the ground to prevent bucket movement post pin removal.
3. Remove the two nuts at the upfront as shown. Remove the bolts and keep them where they won't be compromised by metal debris or sand grains.

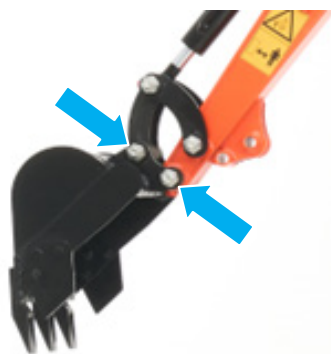

4. Have two people carry the work equipment to be installed and align it with the two holes on the arm.
5. Replace the bolts and tighten the nuts.

## Checking the Bolts and Nuts Tightening Torque

Check the torques of bolts and nuts at initial 50 h or prior to initial use and then every 250 h. Tighten them to the set torque if needed. Replace the damaged with identical ones. Refer to the below tables for required torques.



**ONLY** use a torque wrench to check the torques of bolts and nuts.

Metric Bolts and Nuts			
Thread Dimensions	Standard Torque (Nm)	Thread Dimensions	Standard Torque (Nm)
M6	12±3	M14	160±30
M8	28±7	M16	240±40
M10	55±10	M20	460±60
M12	100±20	M30	1600±200
Main Components Torques (Nm)			
Thread Dimensions		Recommended Torque	
M16 Bolts Fixing the Traveling Motor		252±39.2	
M16 Bolts Fixing the Sprocket		252±39.2	
M20 Bolts Fixing the Slewing Bearing		570±60	

## Miscellaneous Checking Schedule

Parts	Quantity	Interval (h)								
		10	50	100	250	500	1000	2000	4000	
Bucket Teeth Check		★								
Changing the Bucket	—	If needed								
Adjust the Bucket Connecting Rod	1	If needed								
Replacing Traveling Lever	2	If needed								
Check and Replacing the Fuse	1	★	Every 3 years							
Check the Track for Defection	2					★				
Maintaining the Tensioner	2						★			
Check the Fuel Injection Timing	—	If needed								
Measure the Engine Compression Pressure	—					■				
Check the Starter & the A/C Generator	—					■				
Check the Bolts and Nuts Torque	—		◆		★					

### Note:

- ★: Maintenance interval under normal conditions
- ◆: Maintenance needed at the first inspection
- : Contact Customer Service.

## Contact Us

Thank you for choosing our products! If you have any questions or comments, contact us at [help@cs-supportpro.com](mailto:help@cs-supportpro.com) and we'll resolve your issue ASAP!

For a .pdf copy of the latest version of these instructions, use the appropriate app on your smartphone to scan the QR code to the right.

